

PRELIMINARY STORM WATER  
CALCULATIONS

---

---

*Friendship Village*  
*Bloomington, MN*

---

---

Prepared for:

---

**Greystone Communities**  
225 E John Carpenter Freeway, Suite 700  
Irving, TX  
Contact: Pat Gleason  
Phone: 972-402-3758

Prepared by:

---

**Westwood** Professional Services, Inc.  
7699 Anagram Drive  
Eden Prairie, MN 55344  
Phone 952-937-5150, Fax 952-937-5822

Revised: June 8, 2017  
Project # 0009018.00

**SUMMARY**

**SITE CONDITIONS**

The proposed project will consist of the redevelopment of an existing senior living community. The proposed construction will consist of the removal of existing structures and the addition of two new apartment buildings. A portion of the existing roads will be replaced and a small amount of new road will be added. The proposed project will disturb 16.1 acres.

**Project Area Summary**

	Area (AC.)
Total Project Area	25.1
Total Existing Impervious	12.0
Total Proposed Disturbed Impervious	3.1
Total Proposed New Impervious	5.1

Under the Nine Mile Creek Watershed guidelines for redevelopment the disturbed area will not disturb 50% of the impervious and it will not increase the impervious by more than 50%, and falls under section 4.3 guidelines.

The site has been modeled as Type “B” soils, and curve numbers were obtained from “Technical Release 55: Urban Hydrology for Small Watersheds.” For existing conditions, a curve number of 98 was used for existing impervious areas, 98 for the existing pond, and 61 for the existing green areas.

For proposed conditions, a curve number of 98 was used for existing impervious (not removed) and proposed impervious areas, 98 for the proposed pond (modified existing pond), and 61 for proposed green areas.

Refer to the attached drainage area plans for the existing and proposed drainage areas and the attached geotechnical report for soil conditions.

**NINE MILE CREEK WATERSHED DISTRICT REQUIREMENTS**

The proposed development was designed to exceed the following Nine Mile Creek Watershed District (NMCWD) rules for stormwater management:

1. Retention/Infiltration of 1.0 inches of runoff from the proposed impervious surfaces.
2. Water quality for the proposed development must provide 90% annual removal of total suspended solids and 60% annual removal for total phosphorus.
3. Rate Control for the proposed runoff shall not exceed rates for the 2, 10 and 100 year storm events.

Prior to setting the building elevations, Appendix A – Low Floor Elevation Guidance was reviewed. Due to the existing ponds land locked overflow the buildings low floor was reviewed versus the appendix requirements to ensure compliance.

**SUMMARY**

**ROUTING**

Under existing conditions, 15.99 acres drain to an existing pond/wetland located in the south section of the site. The runoff is conveyed through existing onsite storm sewer. The existing pond provides rate control and treatment before discharging through a 24" culvert to the south. The existing pond is land locked and does not have an overflow.

For proposed conditions the overall drainage pattern will remain the same with all flows directed to the existing pond through the onsite storm sewer system. To meet the NMCWD rules an infiltration basin and three underground stormwater systems will be added. These new features will provide retention for the 1 inch event and larger events will be bypassed to the existing pond. In addition, the existing pond will be reconfigured as part of the proposed construction.

**RATE CONTROL**

Based on NMCWD rules peak runoff rates for proposed conditions must be limited to the existing conditions. In addition the high water levels of the pond were reviewed for the 2, 10 and 100 year back to back events.

The following tables compare the proposed redevelopment plan to the existing pond for peak flows for the 2, 10, and 100 year storm events, and the high water levels for the 2, 10, 100, and 100 back to back storm events.

<b>Rate Control</b>			
	2 year (cfs)	10 year (cfs)	100 year (cfs)
Existing	1.53	4.84	15.24
Proposed	1.40	2.98	8.86

<b>Pond-High Water Levels</b>				
	2 year	10 year	100 year	100 year Back to Back
Existing	844.51	844.95	846.01	846.79
Proposed	844.36	845.17	847.00	847.91

Please see Appendix A-B for further information.

**RETENTION**

Per NMCWD rules the site must infiltrate 1.0 inch of runoff from the new impervious surface. It was determined that there is 5.1 acres of newly created impervious area for the development. The runoff volume for a 1.0 inch event is 0.43 ac-ft (4.2 acres x 1.0 inch).

The treatment on-site will consist of an infiltration basin, two underground infiltration systems, and one underground filtration basin.

Soil borings at various locations on site show the different soil types and water levels throughout the site (Appendix D). Soil borings near the infiltration basin show CL (infiltration

**SUMMARY**

rate of 0.06 in/hr). To allow for a better rate, it is recommended to excavate soil 3 feet to allow for infiltration into SM soil with an infiltration rate of 0.45 in/hr.

Soil borings near underground storage 2 show SM (infiltration rate of 0.45 in/hr) and CL (infiltration rate of 0.06 in/hr). The infiltration underground storage will be located closer to the SM boring so an infiltration rate of 0.45 in/hr was used. Soil borings near underground storage 3 show SM and SP-SM soil both with an infiltration rate of 0.45 in/hr.

The Minnesota Stormwater Manual requires a 48 hour drawdown time. With an infiltration rate of 0.45 in/hr, the maximum depth of ponding for the proposed basin and underground infiltration storage locations is 1.8 feet (48 hr \* 0.45 in/hr).

Soil borings near the proposed underground filtration system show poor soil (type D) and high water levels so infiltration was not allowed by the MPCA requirements for use in this area. Other locations in this drainage area were looked at but because of existing utilities, soil type, and water levels there were no reasonable locations. As much of the runoff as possible was routed to storage system 2 and a much smaller underground filtration system is proposed to provide treatment through proposed sands (infiltration rate of 1.63 in/hr) for the remaining small portion of untreated road remaining.

With an infiltration rate of 1.63 in/hr, the maximum depth of ponding for the proposed underground filtration storage location is 6.5 feet (48 hr \* 0.45 in/hr). A depth of 2.25 feet was used at this location because the maximum depth of the chambers is 2.5 feet.

Underground systems 3 and 4 are designed per the StormTech SC-740 chamber details, and underground system 2 is designed per the StormTech MC-4500 chamber details. The depth of stone above the chambers is 6" for storage system 4 but was increased to 12" for storage systems 2 and 3.

The following table shows the sizing and design parameters for retention. Stormtech designs can be found in Appendix C.

Detention Area	Infiltration Rate (in/hr)	Impervious Area (SF)	Req. WQV (CF)	Req. Depth (FT)	Req. Surface Area (SF)	Provided Area (SF)
1	0.45	43996	3666.3	1.8	2037	2831
2	0.45	43996	3666.3	1.8	2037	2268
3	0.45	89298	7441.5	1.8	4134	4162
4	1.63	33977	2831.4	2.25*	1258	1272

\*Maximum depth allowed for size of chambers.

**WATER QUALITY**

We created a P8 model for the proposed runoff of our site to obtain the annual removal efficiency for phosphorus and total suspended solids for our proposed improvements. Based on this model, the current proposed system provides 98% total suspended solids removal and 84% of the total phosphorus removal, greater than the Nine Mile Creek Watershed requirements that require 90% total suspended solids removal and 60% total phosphorus removal. See Appendix C for more details.

**SUMMARY**

---

**Appendix**

Appendix A	<b><u>Existing Conditions</u></b> 2 yr Hydrographs 10 yr Hydrographs 100 yr Hydrographs 100 yr Back-Back Hydrographs
Appendix B	<b><u>Proposed Conditions</u></b> 2 yr Hydrographs 10 yr Hydrographs 100 yr Hydrographs 100 yr Back-Back Hydrographs
Appendix C	Water Quality Basin Volumes Stormtech Design Parameters Pre-Development Drainage Areas Plan Post-Development Drainage Areas Plan
Appendix D	Geotechnical Report

## APPENDIX A

### **Existing Conditions**

2-YR HYDROGRAPHS

10-YR HYDROGRAPHS

100-YR HYDROGRAPHS

100 yr BACK-BACK HYDROGRAPHS

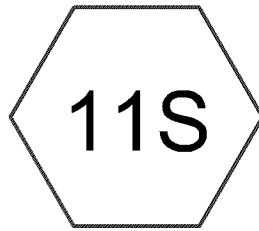

Existing Drainage

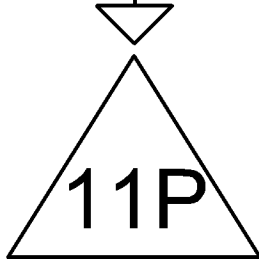

Existing Pond

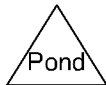
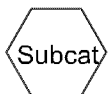

**17-06-05-Friendship village design**

MSE 24-hr 3 2 yr Rainfall=2.86"

Prepared by Westwood Professional Services, Inc.  
HydroCAD® 10.00-19 s/n 03363 © 2016 HydroCAD Software Solutions LLC

Printed 6/6/2017

Page 2

**Summary for Subcatchment 11S: Existing Drainage**

Runoff = 21.33 cfs @ 12.28 hrs, Volume= 1.527 af, Depth= 1.15"

Runoff by SCS TR-20 method, UH=SCS, Weighted-CN, Time Span= 0.00-72.00 hrs, dt= 0.01 hrs  
MSE 24-hr 3 2 yr Rainfall=2.86"

Area (ac)	CN	Description
6.500	98	Paved roads w/curbs & sewers, HSG B
7.640	61	>75% Grass cover, Good, HSG B
1.850	98	Water Surface, HSG B
15.990	80	Weighted Average
7.640		47.78% Pervious Area
8.350		52.22% Impervious Area

Tc (min)	Length (feet)	Slope (ft/ft)	Velocity (ft/sec)	Capacity (cfs)	Description
18.0					Direct Entry,

**Summary for Pond 11P: Existing Pond**

Inflow Area = 15.990 ac, 52.22% Impervious, Inflow Depth = 1.15" for 2 yr event  
 Inflow = 21.33 cfs @ 12.28 hrs, Volume= 1.527 af  
 Outflow = 1.53 cfs @ 13.78 hrs, Volume= 1.417 af, Atten= 93%, Lag= 90.0 min  
 Primary = 1.53 cfs @ 13.78 hrs, Volume= 1.417 af

Routing by Sim-Route method, Time Span= 0.00-72.00 hrs, dt= 0.01 hrs  
 Peak Elev= 844.51' @ 13.78 hrs Surf.Area= 1.883 ac Storage= 0.951 af

Plug-Flow detention time= 591.0 min calculated for 1.417 af (93% of inflow)  
 Center-of-Mass det. time= 557.0 min ( 1,386.8 - 829.7 )

Volume	Invert	Avail.Storage	Storage Description
#1	844.00'	17.557 af	<b>Custom Stage Data (Prismatic)</b> Listed below (Recalc)
Elevation (feet)	Surf.Area (acres)	Inc.Store (acre-feet)	Cum.Store (acre-feet)
844.00	1.848	0.000	0.000
846.00	1.986	3.834	3.834
848.00	2.164	4.150	7.983
850.00	2.340	4.503	12.486
852.00	2.731	5.070	17.557

Device	Routing	Invert	Outlet Devices
#1	Primary	844.00'	<b>24.0" Round Culvert</b> L= 101.0' RCP, end-section conforming to fill, Ke= 0.500 Inlet / Outlet Invert= 844.00' / 841.15' S= 0.0282 1' Cc= 0.900 n= 0.013 Concrete pipe, straight & clean, Flow Area= 3.14 sf
#2	Primary	851.00'	<b>20.0' long x 0.5' breadth Broad-Crested Rectangular Weir</b> Head (feet) 0.20 0.40 0.60 0.80 1.00 Coef. (English) 2.80 2.92 3.08 3.30 3.32

**17-06-05-Friendship village design**

MSE 24-hr 3 2 yr Rainfall=2.86"

Prepared by Westwood Professional Services, Inc.

Printed 6/6/2017

HydroCAD® 10.00-19 s/n 03363 © 2016 HydroCAD Software Solutions LLC

Page 3

**Primary OutFlow** Max=1.53 cfs @ 13.78 hrs HW=844.51' (Free Discharge)

└─1=Culvert (Inlet Controls 1.53 cfs @ 2.43 fps)

└─2=Broad-Crested Rectangular Weir ( Controls 0.00 cfs)

**17-06-05-Friendship village design**

MSE 24-hr 3 10 yr Rainfall=4.27"

Prepared by Westwood Professional Services, Inc.  
HydroCAD® 10.00-19 s/n 03363 © 2016 HydroCAD Software Solutions LLC

Printed 6/6/2017  
Page 4

**Summary for Subcatchment 11S: Existing Drainage**

Runoff = 42.85 cfs @ 12.27 hrs, Volume= 3.021 af, Depth= 2.27"

Runoff by SCS TR-20 method, UH=SCS, Weighted-CN, Time Span= 0.00-72.00 hrs, dt= 0.01 hrs  
MSE 24-hr 3 10 yr Rainfall=4.27"

Area (ac)	CN	Description
6.500	98	Paved roads w/curbs & sewers, HSG B
7.640	61	>75% Grass cover, Good, HSG B
1.850	98	Water Surface, HSG B
15.990	80	Weighted Average
7.640		47.78% Pervious Area
8.350		52.22% Impervious Area

Tc (min)	Length (feet)	Slope (ft/ft)	Velocity (ft/sec)	Capacity (cfs)	Description
18.0					Direct Entry,

**Summary for Pond 11P: Existing Pond**

Inflow Area = 15.990 ac, 52.22% Impervious, Inflow Depth = 2.27" for 10 yr event  
 Inflow = 42.85 cfs @ 12.27 hrs, Volume= 3.021 af  
 Outflow = 4.84 cfs @ 13.32 hrs, Volume= 2.906 af, Atten= 89%, Lag= 62.9 min  
 Primary = 4.84 cfs @ 13.32 hrs, Volume= 2.906 af

Routing by Sim-Route method, Time Span= 0.00-72.00 hrs, dt= 0.01 hrs  
 Peak Elev= 844.95' @ 13.32 hrs Surf.Area= 1.913 ac Storage= 1.778 af

Plug-Flow detention time= 416.6 min calculated for 2.905 af (96% of inflow)  
 Center-of-Mass det. time= 397.0 min ( 1,212.6 - 815.6 )

Volume	Invert	Avail.Storage	Storage Description
#1	844.00'	17.557 af	<b>Custom Stage Data (Prismatic)</b> Listed below (Recalc)
Elevation (feet)	Surf.Area (acres)	Inc.Store (acre-feet)	Cum.Store (acre-feet)
844.00	1.848	0.000	0.000
846.00	1.986	3.834	3.834
848.00	2.164	4.150	7.983
850.00	2.340	4.503	12.486
852.00	2.731	5.070	17.557

Device	Routing	Invert	Outlet Devices
#1	Primary	844.00'	<b>24.0" Round Culvert</b> L= 101.0' RCP, end-section conforming to fill, Ke= 0.500 Inlet / Outlet Invert= 844.00' / 841.15' S= 0.0282 1' Cc= 0.900 n= 0.013 Concrete pipe, straight & clean, Flow Area= 3.14 sf
#2	Primary	851.00'	<b>20.0' long x 0.5' breadth Broad-Crested Rectangular Weir</b> Head (feet) 0.20 0.40 0.60 0.80 1.00 Coef. (English) 2.80 2.92 3.08 3.30 3.32

**17-06-05-Friendship village design**

*MSE 24-hr 3 10 yr Rainfall=4.27"*

Prepared by Westwood Professional Services, Inc.

Printed 6/6/2017

HydroCAD® 10.00-19 s/n 03363 © 2016 HydroCAD Software Solutions LLC

Page 5

**Primary OutFlow** Max=4.84 cfs @ 13.32 hrs HW=844.95' (Free Discharge)

└─1=Culvert (Inlet Controls 4.84 cfs @ 3.31 fps)

└─2=Broad-Crested Rectangular Weir ( Controls 0.00 cfs)

**17-06-05-Friendship village design**

MSE 24-hr 3 100 yr Rainfall=7.46"

Prepared by Westwood Professional Services, Inc.

Printed 6/6/2017

HydroCAD® 10.00-19 s/n 03363 © 2016 HydroCAD Software Solutions LLC

Page 6

**Summary for Subcatchment 11S: Existing Drainage**

Runoff = 95.70 cfs @ 12.26 hrs, Volume= 6.823 af, Depth= 5.12"

Runoff by SCS TR-20 method, UH=SCS, Weighted-CN, Time Span= 0.00-72.00 hrs, dt= 0.01 hrs  
MSE 24-hr 3 100 yr Rainfall=7.46"

Area (ac)	CN	Description
6.500	98	Paved roads w/curbs & sewers, HSG B
7.640	61	>75% Grass cover, Good, HSG B
1.850	98	Water Surface, HSG B
15.990	80	Weighted Average
7.640		47.78% Pervious Area
8.350		52.22% Impervious Area

Tc (min)	Length (feet)	Slope (ft/ft)	Velocity (ft/sec)	Capacity (cfs)	Description
18.0					<b>Direct Entry,</b>

**Summary for Pond 11P: Existing Pond**

Inflow Area = 15.990 ac, 52.22% Impervious, Inflow Depth = 5.12" for 100 yr event  
 Inflow = 95.70 cfs @ 12.26 hrs, Volume= 6.823 af  
 Outflow = 15.24 cfs @ 12.90 hrs, Volume= 6.703 af, Atten= 84%, Lag= 37.9 min  
 Primary = 15.24 cfs @ 12.90 hrs, Volume= 6.703 af

Routing by Sim-Route method, Time Span= 0.00-72.00 hrs, dt= 0.01 hrs  
 Peak Elev= 846.01' @ 12.90 hrs Surf.Area= 1.987 ac Storage= 3.863 af

Plug-Flow detention time= 282.3 min calculated for 6.702 af (98% of inflow)  
 Center-of-Mass det. time= 272.5 min ( 1,071.8 - 799.2 )

Volume	Invert	Avail.Storage	Storage Description
#1	844.00'	17.557 af	<b>Custom Stage Data (Prismatic)</b> Listed below (Recalc)
Elevation (feet)	Surf.Area (acres)	Inc.Store (acre-feet)	Cum.Store (acre-feet)
844.00	1.848	0.000	0.000
846.00	1.986	3.834	3.834
848.00	2.164	4.150	7.983
850.00	2.340	4.503	12.486
852.00	2.731	5.070	17.557

Device	Routing	Invert	Outlet Devices
#1	Primary	844.00'	<b>24.0" Round Culvert</b> L= 101.0' RCP, end-section conforming to fill, Ke= 0.500 Inlet / Outlet Invert= 844.00' / 841.15' S= 0.0282 1' Cc= 0.900 n= 0.013 Concrete pipe, straight & clean, Flow Area= 3.14 sf
#2	Primary	851.00'	<b>20.0' long x 0.5' breadth Broad-Crested Rectangular Weir</b> Head (feet) 0.20 0.40 0.60 0.80 1.00 Coef. (English) 2.80 2.92 3.08 3.30 3.32

**17-06-05-Friendship village design**

MSE 24-hr 3 100 yr Rainfall=7.46"

Prepared by Westwood Professional Services, Inc.

Printed 6/6/2017

HydroCAD® 10.00-19 s/n 03363 © 2016 HydroCAD Software Solutions LLC

Page 7

**Primary OutFlow** Max=15.24 cfs @ 12.90 hrs HW=846.01' (Free Discharge)

└─1=Culvert (Inlet Controls 15.24 cfs @ 4.85 fps)

└─2=Broad-Crested Rectangular Weir ( Controls 0.00 cfs)

**17-06-05-Friendship village design**

MSE 24-hr 3 100 yr back to back Rainfall=7.46" x 2

Prepared by Westwood Professional Services, Inc.

Printed 6/6/2017

HydroCAD® 10.00-19 s/n 03363 © 2016 HydroCAD Software Solutions LLC

Page 8

**Summary for Subcatchment 11S: Existing Drainage**

Runoff = 114.78 cfs @ 36.26 hrs, Volume= 16.376 af, Depth=12.29"

Runoff by SCS TR-20 method, UH=SCS, Weighted-CN, Time Span= 0.00-72.00 hrs, dt= 0.01 hrs  
MSE 24-hr 3 100 yr back to back Rainfall=7.46" x 2

Area (ac)	CN	Description
6.500	98	Paved roads w/curbs & sewers, HSG B
7.640	61	>75% Grass cover, Good, HSG B
1.850	98	Water Surface, HSG B
15.990	80	Weighted Average
7.640		47.78% Pervious Area
8.350		52.22% Impervious Area

Tc (min)	Length (feet)	Slope (ft/ft)	Velocity (ft/sec)	Capacity (cfs)	Description
18.0					<b>Direct Entry,</b>

**Summary for Pond 11P: Existing Pond**

Inflow Area = 15.990 ac, 52.22% Impervious, Inflow Depth = 12.29" for 100 yr back to back event  
 Inflow = 114.78 cfs @ 36.26 hrs, Volume= 16.376 af  
 Outflow = 20.23 cfs @ 36.80 hrs, Volume= 16.159 af, Atten= 82%, Lag= 32.7 min  
 Primary = 20.23 cfs @ 36.80 hrs, Volume= 16.159 af

Routing by Sim-Route method, Time Span= 0.00-72.00 hrs, dt= 0.01 hrs  
 Peak Elev= 846.79' @ 36.80 hrs Surf.Area= 2.056 ac Storage= 5.427 af

Plug-Flow detention time= 255.1 min calculated for 16.157 af (99% of inflow)  
 Center-of-Mass det. time= 239.7 min ( 1,843.9 - 1,604.1 )

Volume	Invert	Avail.Storage	Storage Description
#1	844.00'	17.557 af	<b>Custom Stage Data (Prismatic)</b> Listed below (Recalc)
Elevation (feet)	Surf.Area (acres)	Inc.Store (acre-feet)	Cum.Store (acre-feet)
844.00	1.848	0.000	0.000
846.00	1.986	3.834	3.834
848.00	2.164	4.150	7.983
850.00	2.340	4.503	12.486
852.00	2.731	5.070	17.557

Device	Routing	Invert	Outlet Devices
#1	Primary	844.00'	<b>24.0" Round Culvert</b> L= 101.0' RCP, end-section conforming to fill, Ke= 0.500 Inlet / Outlet Invert= 844.00' / 841.15' S= 0.0282 1' Cc= 0.900 n= 0.013 Concrete pipe, straight & clean, Flow Area= 3.14 sf
#2	Primary	851.00'	<b>20.0' long x 0.5' breadth Broad-Crested Rectangular Weir</b> Head (feet) 0.20 0.40 0.60 0.80 1.00 Coef. (English) 2.80 2.92 3.08 3.30 3.32

**17-06-05-Friendship village design**

*MSE 24-hr 3 100 yr back to back Rainfall=7.46" x 2*

Prepared by Westwood Professional Services, Inc.

Printed 6/6/2017

HydroCAD® 10.00-19 s/n 03363 © 2016 HydroCAD Software Solutions LLC

Page 9

**Primary OutFlow** Max=20.23 cfs @ 36.80 hrs HW=846.79' (Free Discharge)

└─1=Culvert (Inlet Controls 20.23 cfs @ 6.44 fps)

└─2=Broad-Crested Rectangular Weir ( Controls 0.00 cfs)

## APPENDIX B

### **Proposed Conditions**

2-YR HYDROGRAPHS

10-YR HYDROGRAPHS

100-YR HYDROGRAPHS

100 yr BACK-BACK HYDROGRAPHS

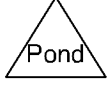
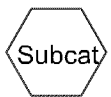
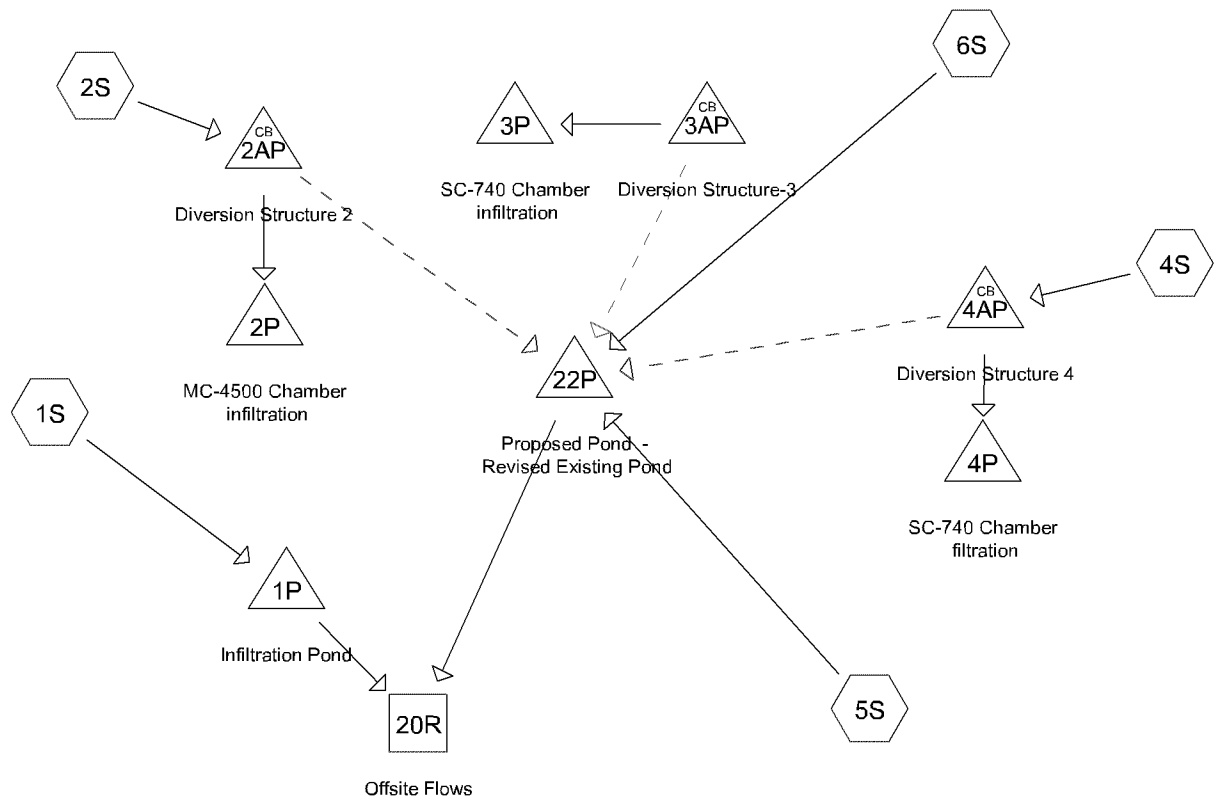

**Routing Diagram for 17-06-05-Friendship village design**  
 Prepared by Westwood Professional Services, Inc., Printed 6/8/2017  
 HydroCAD® 10.00-19 s/n 03363 © 2016 HydroCAD Software Solutions LLC

**17-06-05-Friendship village design**

MSE 24-hr 3 2 yr Rainfall=2.86"

Prepared by Westwood Professional Services, Inc.

Printed 6/8/2017

HydroCAD® 10.00-19 s/n 03363 © 2016 HydroCAD Software Solutions LLC

Page 2

**Summary for Subcatchment 1S:**

Runoff = 3.55 cfs @ 12.18 hrs, Volume= 0.190 af, Depth= 1.47"

Runoff by SCS TR-20 method, UH=SCS, Weighted-CN, Time Span= 0.00-72.00 hrs, dt= 0.01 hrs  
MSE 24-hr 3 2 yr Rainfall=2.86"

Area (ac)	CN	Description
1.010	98	Paved parking, HSG B
0.540	61	>75% Grass cover, Good, HSG B
1.550	85	Weighted Average
0.540		34.84% Pervious Area
1.010		65.16% Impervious Area

Tc (min)	Length (feet)	Slope (ft/ft)	Velocity (ft/sec)	Capacity (cfs)	Description
10.0					Direct Entry,

**Summary for Subcatchment 2S:**

Runoff = 2.91 cfs @ 12.24 hrs, Volume= 0.188 af, Depth= 1.21"

Runoff by SCS TR-20 method, UH=SCS, Weighted-CN, Time Span= 0.00-72.00 hrs, dt= 0.01 hrs  
MSE 24-hr 3 2 yr Rainfall=2.86"

Area (ac)	CN	Description
1.010	98	Paved parking, HSG B
0.860	61	>75% Grass cover, Good, HSG B
1.870	81	Weighted Average
0.860		45.99% Pervious Area
1.010		54.01% Impervious Area

Tc (min)	Length (feet)	Slope (ft/ft)	Velocity (ft/sec)	Capacity (cfs)	Description
15.0					Direct Entry,

**Summary for Subcatchment 4S:**

Runoff = 2.69 cfs @ 12.19 hrs, Volume= 0.149 af, Depth= 0.87"

Runoff by SCS TR-20 method, UH=SCS, Weighted-CN, Time Span= 0.00-72.00 hrs, dt= 0.01 hrs  
MSE 24-hr 3 2 yr Rainfall=2.86"

Area (ac)	CN	Description
* 0.780	98	Paved parking, HSG B
1.280	61	>75% Grass cover, Good, HSG B
2.060	75	Weighted Average
1.280		62.14% Pervious Area
0.780		37.86% Impervious Area

**17-06-05-Friendship village design**

MSE 24-hr 3 2 yr Rainfall=2.86"

Prepared by Westwood Professional Services, Inc.  
 HydroCAD® 10.00-19 s/n 03363 © 2016 HydroCAD Software Solutions LLC

Printed 6/8/2017

Page 3

Tc (min)	Length (feet)	Slope (ft/ft)	Velocity (ft/sec)	Capacity (cfs)	Description
10.0					<b>Direct Entry,</b>

**Summary for Subcatchment 5S:**

Runoff = 7.82 cfs @ 12.18 hrs, Volume= 0.421 af, Depth= 1.15"

Runoff by SCS TR-20 method, UH=SCS, Weighted-CN, Time Span= 0.00-72.00 hrs, dt= 0.01 hrs  
 MSE 24-hr 3 2 yr Rainfall=2.86"

Area (ac)	CN	Description
1.190	98	Paved roads w/curbs & sewers, HSG B
2.200	61	>75% Grass cover, Good, HSG B
1.020	98	Water Surface, HSG B
4.410	80	Weighted Average
2.200		49.89% Pervious Area
2.210		50.11% Impervious Area

Tc (min)	Length (feet)	Slope (ft/ft)	Velocity (ft/sec)	Capacity (cfs)	Description
10.0					<b>Direct Entry,</b>

**Summary for Subcatchment 6S:**

Runoff = 6.25 cfs @ 12.24 hrs, Volume= 0.403 af, Depth= 1.21"

Runoff by SCS TR-20 method, UH=SCS, Weighted-CN, Time Span= 0.00-72.00 hrs, dt= 0.01 hrs  
 MSE 24-hr 3 2 yr Rainfall=2.86"

Area (ac)	CN	Description
2.200	98	Paved parking, HSG B
1.810	61	>75% Grass cover, Good, HSG B
4.010	81	Weighted Average
1.810		45.14% Pervious Area
2.200		54.86% Impervious Area

Tc (min)	Length (feet)	Slope (ft/ft)	Velocity (ft/sec)	Capacity (cfs)	Description
15.0					<b>Direct Entry,</b>

**Summary for Reach 20R: Offsite Flows**

Inflow Area = 9.970 ac, 54.36% Impervious, Inflow Depth > 1.43" for 2 yr event  
 Inflow = 1.40 cfs @ 13.66 hrs, Volume= 1.185 af  
 Outflow = 1.40 cfs @ 13.67 hrs, Volume= 1.185 af, Atten= 0%, Lag= 0.6 min

**17-06-05-Friendship village design**

MSE 24-hr 3 2 yr Rainfall=2.86"

Prepared by Westwood Professional Services, Inc.  
HydroCAD® 10.00-19 s/n 03363 © 2016 HydroCAD Software Solutions LLC

Printed 6/8/2017

Page 4

Routing by Sim-Route method, Time Span= 0.00-72.00 hrs, dt= 0.01 hrs

**Summary for Pond 1P: Infiltration Pond**

Inflow Area = 1.550 ac, 65.16% Impervious, Inflow Depth = 1.47" for 2 yr event  
 Inflow = 3.55 cfs @ 12.18 hrs, Volume= 0.190 af  
 Outflow = 0.13 cfs @ 14.25 hrs, Volume= 0.189 af, Atten= 96%, Lag= 124.1 min  
 Discarded = 0.04 cfs @ 14.25 hrs, Volume= 0.158 af  
 Primary = 0.09 cfs @ 14.25 hrs, Volume= 0.031 af

Routing by Sim-Route method, Time Span= 0.00-72.00 hrs, dt= 0.01 hrs  
 Peak Elev= 854.98' @ 14.25 hrs Surf.Area= 0.088 ac Storage= 0.134 af

Plug-Flow detention time= 1,275.2 min calculated for 0.189 af (100% of inflow)  
 Center-of-Mass det. time= 1,272.4 min ( 2,082.3 - 809.8 )

Volume	Invert	Avail.Storage	Storage Description
#1	853.00'	0.653 af	<b>Custom Stage Data (Prismatic)</b> Listed below (Recalc)
Elevation (feet)	Surf.Area (acres)	Inc.Store (acre-feet)	Cum.Store (acre-feet)
853.00	0.048	0.000	0.000
854.00	0.067	0.058	0.058
855.00	0.089	0.078	0.136
856.00	0.115	0.102	0.237
857.00	0.144	0.129	0.367
858.00	0.429	0.286	0.653

Device	Routing	Invert	Outlet Devices
#1	Primary	857.50'	<b>5.0' long x 1.0' breadth Broad-Crested Rectangular Weir</b> Head (feet) 0.20 0.40 0.60 0.80 1.00 1.20 1.40 1.60 1.80 2.00 2.50 3.00 Coef. (English) 2.69 2.72 2.75 2.85 2.98 3.08 3.20 3.28 3.31 3.30 3.31 3.32
#2	Discarded	853.00'	<b>0.450 in/hr Exfiltration over Surface area</b> Phase-In= 0.05'
#3	Primary	851.00'	<b>12.0" Round Culvert</b> L= 98.0' Ke= 0.500 Inlet / Outlet Invert= 851.00' / 850.51' S= 0.0050 ' / ' Cc= 0.900 n= 0.012 Concrete pipe, finished, Flow Area= 0.79 sf
#4	Device 3	854.80'	<b>6.0" Vert. Orifice/Grate</b> C= 0.600
#5	Device 3	857.50'	<b>48.0" Horiz. Orifice/Grate</b> C= 0.600 Limited to weir flow at low heads

**Discarded OutFlow** Max=0.04 cfs @ 14.25 hrs HW=854.98' (Free Discharge)

↑ **2=Exfiltration** (Exfiltration Controls 0.04 cfs)

**Primary OutFlow** Max=0.09 cfs @ 14.25 hrs HW=854.98' TW=0.00' (Dynamic Tailwater)

- ↑ **1=Broad-Crested Rectangular Weir** ( Controls 0.00 cfs)
- ↑ **3=Culvert** (Passes 0.09 cfs of 5.78 cfs potential flow)
- ↑ **4=Orifice/Grate** (Orifice Controls 0.09 cfs @ 1.43 fps)
- ↑ **5=Orifice/Grate** ( Controls 0.00 cfs)

**17-06-05-Friendship village design**

MSE 24-hr 3 2 yr Rainfall=2.86"

Prepared by Westwood Professional Services, Inc.  
HydroCAD® 10.00-19 s/n 03363 © 2016 HydroCAD Software Solutions LLC

Printed 6/8/2017

Page 5

**Summary for Pond 2AP: Diversion Structure 2**

Inflow Area = 1.870 ac, 54.01% Impervious, Inflow Depth = 1.21" for 2 yr event  
 Inflow = 2.91 cfs @ 12.24 hrs, Volume= 0.188 af  
 Outflow = 2.91 cfs @ 12.25 hrs, Volume= 0.188 af, Atten= 0%, Lag= 0.6 min  
 Primary = 2.04 cfs @ 12.25 hrs, Volume= 0.146 af  
 Secondary = 0.88 cfs @ 12.25 hrs, Volume= 0.042 af

Routing by Sim-Route method, Time Span= 0.00-72.00 hrs, dt= 0.01 hrs  
 Peak Elev= 845.48' @ 12.25 hrs

Device	Routing	Invert	Outlet Devices
#1	Primary	844.50'	<b>12.0" Round Culvert</b> L= 4.0' Ke= 0.500 Inlet / Outlet Invert= 844.50' / 844.48' S= 0.0050 ' S= 0.0050 ' Cc= 0.900 n= 0.012 Concrete pipe, finished, Flow Area= 0.79 sf
#2	Secondary	845.10'	<b>24.0" Round Culvert</b> L= 273.0' Ke= 0.500 Inlet / Outlet Invert= 845.10' / 843.60' S= 0.0055 ' S= 0.0055 ' Cc= 0.900 n= 0.005, Flow Area= 3.14 sf

**Primary OutFlow** Max=2.04 cfs @ 12.25 hrs HW=845.48' TW=843.13' (Dynamic Tailwater)  
 ↑ **1=Culvert** (Barrel Controls 2.04 cfs @ 3.28 fps)

**Secondary OutFlow** Max=0.88 cfs @ 12.25 hrs HW=845.48' TW=843.99' (Dynamic Tailwater)  
 ↑ **2=Culvert** (Inlet Controls 0.88 cfs @ 2.10 fps)

**Summary for Pond 2P: MC-4500 Chamber infiltration**

Inflow Area = 1.870 ac, 54.01% Impervious, Inflow Depth = 0.94" for 2 yr event  
 Inflow = 2.04 cfs @ 12.25 hrs, Volume= 0.146 af  
 Outflow = 0.02 cfs @ 11.48 hrs, Volume= 0.119 af, Atten= 99%, Lag= 0.0 min  
 Discarded = 0.02 cfs @ 11.48 hrs, Volume= 0.119 af

Routing by Sim-Route method, Time Span= 0.00-72.00 hrs, dt= 0.01 hrs  
 Peak Elev= 845.22' @ 15.17 hrs Surf.Area= 0.052 ac Storage= 0.125 af

Plug-Flow detention time= 1,750.5 min calculated for 0.119 af (81% of inflow)  
 Center-of-Mass det. time= 1,701.7 min ( 2,498.3 - 796.5 )

Volume	Invert	Avail.Storage	Storage Description
#1A	841.75'	0.112 af	<b>28.50"W x 79.57"L x 8.00"H Field A</b> 0.416 af Overall - 0.137 af Embedded = 0.280 af x 40.0% Voids
#2A	842.75'	0.137 af	<b>ADS_StormTech MC-4500 +Cap</b> x 54 Inside #1 Effective Size= 90.4"W x 60.0"H => 26.46 sf x 4.03'L = 106.5 cf Overall Size= 100.0"W x 60.0"H x 4.33'L with 0.31' Overlap 3 Rows of 18 Chambers Cap Storage= +35.7 cf x 2 x 3 rows = 214.2 cf
		0.249 af	Total Available Storage

Storage Group A created with Chamber Wizard

**17-06-05-Friendship village design**

MSE 24-hr 3 2 yr Rainfall=2.86"

Prepared by Westwood Professional Services, Inc.

Printed 6/8/2017

HydroCAD® 10.00-19 s/n 03363 © 2016 HydroCAD Software Solutions LLC

Page 6

Device	Routing	Invert	Outlet Devices
#1	Discarded	841.75'	<b>0.450 in/hr Exfiltration over Surface area</b> Phase-In= 0.05'

**Discarded OutFlow** Max=0.02 cfs @ 11.48 hrs HW=841.80' (Free Discharge)

↑1=Exfiltration (Exfiltration Controls 0.02 cfs)

**Summary for Pond 3AP: Diversion Structure-3**

Inflow Area = 2.280 ac, 89.91% Impervious, Inflow Depth = 2.21" for 2 yr event  
 Inflow = 6.33 cfs @ 12.22 hrs, Volume= 0.421 af  
 Outflow = 6.33 cfs @ 12.23 hrs, Volume= 0.421 af, Atten= 0%, Lag= 0.6 min  
 Primary = 0.78 cfs @ 12.23 hrs, Volume= 0.188 af  
 Secondary = 5.55 cfs @ 12.23 hrs, Volume= 0.233 af

Routing by Sim-Route method, Time Span= 0.00-72.00 hrs, dt= 0.01 hrs  
 Peak Elev= 853.63' @ 12.23 hrs

Device	Routing	Invert	Outlet Devices
#1	Primary	852.00'	<b>5.0" Round Culvert</b> L= 9.0' Ke= 0.500 Inlet / Outlet Invert= 852.00' / 851.95' S= 0.0056 '/ Cc= 0.900 n= 0.012 Concrete pipe, finished, Flow Area= 0.14 sf
#2	Secondary	852.50'	<b>24.0" Round Culvert</b> L= 25.0' RCP, sq.cut end projecting, Ke= 0.500 Inlet / Outlet Invert= 852.50' / 852.25' S= 0.0100 '/ Cc= 0.900 n= 0.012 Concrete pipe, finished, Flow Area= 3.14 sf

**Primary OutFlow** Max=0.78 cfs @ 12.23 hrs HW=853.63' TW=851.12' (Dynamic Tailwater)

↑1=Culvert (Inlet Controls 0.78 cfs @ 5.75 fps)

**Secondary OutFlow** Max=5.54 cfs @ 12.23 hrs HW=853.63' TW=843.96' (Dynamic Tailwater)

↑2=Culvert (Barrel Controls 5.54 cfs @ 4.36 fps)

**Summary for Pond 3P: SC-740 Chamber infiltration**

Inflow Area = 2.280 ac, 89.91% Impervious, Inflow Depth = 0.99" for 2 yr event  
 Inflow = 0.78 cfs @ 12.23 hrs, Volume= 0.188 af  
 Outflow = 0.04 cfs @ 8.90 hrs, Volume= 0.188 af, Atten= 95%, Lag= 0.0 min  
 Discarded = 0.04 cfs @ 8.90 hrs, Volume= 0.188 af

Routing by Sim-Route method, Time Span= 0.00-72.00 hrs, dt= 0.01 hrs  
 Peak Elev= 852.60' @ 17.40 hrs Surf.Area= 0.078 ac Storage= 0.144 af

Plug-Flow detention time= 1,582.7 min calculated for 0.188 af (100% of inflow)

Center-of-Mass det. time= 1,581.8 min ( 2,376.4 - 794.7 )

Volume	Invert	Avail.Storage	Storage Description
#1A	849.70'	0.102 af	<b>20.50'W x 166.20'L x 4.50'H Field A</b> 0.352 af Overall - 0.097 af Embedded = 0.255 af x 40.0% Voids
#2A	850.70'	0.097 af	<b>ADS_StormTech SC-740</b> x 92 Inside #1 Effective Size= 44.6"W x 30.0"H => 6.45 sf x 7.12'L = 45.9 cf Overall Size= 51.0"W x 30.0"H x 7.56'L with 0.44' Overlap Row Length Adjustment= +0.44' x 6.45 sf x 4 rows

**17-06-05-Friendship village design**

MSE 24-hr 3 2 yr Rainfall=2.86"

Prepared by Westwood Professional Services, Inc.

Printed 6/8/2017

HydroCAD® 10.00-19 s/n 03363 © 2016 HydroCAD Software Solutions LLC

Page 7

0.199 af Total Available Storage

Storage Group A created with Chamber Wizard

Device	Routing	Invert	Outlet Devices
#1	Discarded	849.70'	<b>0.450 in/hr Exfiltration over Surface area</b> Phase-In= 0.05'

**Discarded OutFlow** Max=0.04 cfs @ 8.90 hrs HW=849.75' (Free Discharge)↑**1=Exfiltration** (Exfiltration Controls 0.04 cfs)**Summary for Pond 4AP: Diversion Structure 4**

Inflow Area = 2.060 ac, 37.86% Impervious, Inflow Depth = 0.87" for 2 yr event  
 Inflow = 2.69 cfs @ 12.19 hrs, Volume= 0.149 af  
 Outflow = 2.69 cfs @ 12.20 hrs, Volume= 0.149 af, Atten= 0%, Lag= 0.6 min  
 Primary = 0.06 cfs @ 12.20 hrs, Volume= 0.041 af  
 Secondary = 2.63 cfs @ 12.20 hrs, Volume= 0.108 af

Routing by Sim-Route method, Time Span= 0.00-72.00 hrs, dt= 0.01 hrs

Peak Elev= 846.93' @ 12.20 hrs

Device	Routing	Invert	Outlet Devices
#1	Primary	845.25'	<b>2.0" Round Culvert</b> L= 50.0' Ke= 0.500 Inlet / Outlet Invert= 845.25' / 845.00' S= 0.0050 ' Cc= 0.900 n= 0.012 Concrete pipe, finished, Flow Area= 0.02 sf
#2	Secondary	846.25'	<b>24.0" Round Culvert</b> L= 50.0' Ke= 0.500 Inlet / Outlet Invert= 846.25' / 843.75' S= 0.0500 ' Cc= 0.900 n= 0.012 Concrete pipe, finished, Flow Area= 3.14 sf

**Primary OutFlow** Max=0.06 cfs @ 12.20 hrs HW=846.93' TW=845.06' (Dynamic Tailwater)↑**1=Culvert** (Barrel Controls 0.06 cfs @ 2.66 fps)**Secondary OutFlow** Max=2.63 cfs @ 12.20 hrs HW=846.93' TW=843.89' (Dynamic Tailwater)↑**2=Culvert** (Inlet Controls 2.63 cfs @ 2.80 fps)**Summary for Pond 4P: SC-740 Chamber filtration**

Inflow Area = 2.060 ac, 37.86% Impervious, Inflow Depth = 0.24" for 2 yr event  
 Inflow = 0.06 cfs @ 12.20 hrs, Volume= 0.041 af  
 Outflow = 0.05 cfs @ 12.08 hrs, Volume= 0.041 af, Atten= 17%, Lag= 0.0 min  
 Discarded = 0.05 cfs @ 12.08 hrs, Volume= 0.041 af

Routing by Sim-Route method, Time Span= 0.00-72.00 hrs, dt= 0.01 hrs

Peak Elev= 845.09' @ 13.72 hrs Surf.Area= 0.029 ac Storage= 0.001 af

Plug-Flow detention time= 11.3 min calculated for 0.041 af (100% of inflow)

Center-of-Mass det. time= 11.3 min ( 1,028.2 - 1,016.9 )

**17-06-05-Friendship village design**

MSE 24-hr 3 2 yr Rainfall=2.86"

Prepared by Westwood Professional Services, Inc.

Printed 6/8/2017

HydroCAD® 10.00-19 s/n 03363 © 2016 HydroCAD Software Solutions LLC

Page 8

Volume	Invert	Avail.Storage	Storage Description
#1A	845.00'	0.033 af	<b>15.75'W x 80.76'L x 4.00'H Field A</b> 0.117 af Overall - 0.035 af Embedded = 0.082 af x 40.0% Voids
#2A	846.00'	0.035 af	<b>ADS_StormTech SC-740</b> x 33 Inside #1 Effective Size= 44.6"W x 30.0"H => 6.45 sf x 7.12'L = 45.9 cf Overall Size= 51.0"W x 30.0"H x 7.56'L with 0.44' Overlap Row Length Adjustment= +0.44' x 6.45 sf x 3 rows
		0.068 af	Total Available Storage

Storage Group A created with Chamber Wizard

Device	Routing	Invert	Outlet Devices
#1	Discarded	845.00'	<b>1.630 in/hr Exfiltration over Surface area</b> Phase-In= 0.05'

**Discarded OutFlow** Max=0.05 cfs @ 12.08 hrs HW=845.05' (Free Discharge)

↑**1=Exfiltration** (Exfiltration Controls 0.05 cfs)

**Summary for Pond 22P: Proposed Pond - Revised Existing Pond**

Inflow Area = 8.420 ac, 52.38% Impervious, Inflow Depth = 1.72" for 2 yr event  
 Inflow = 22.20 cfs @ 12.21 hrs, Volume= 1.207 af  
 Outflow = 1.32 cfs @ 13.55 hrs, Volume= 1.154 af, Atten= 94%, Lag= 80.2 min  
 Primary = 1.32 cfs @ 13.55 hrs, Volume= 1.154 af

Routing by Sim-Route method, Time Span= 0.00-72.00 hrs, dt= 0.01 hrs  
 Starting Elev= 843.60' Surf.Area= 0.958 ac Storage= 2.959 af  
 Peak Elev= 844.36' @ 13.55 hrs Surf.Area= 1.076 ac Storage= 3.731 af (0.772 af above start)

Plug-Flow detention time= (not calculated: initial storage exceeds outflow)

Center-of-Mass det. time= 484.8 min ( 1,298.2 - 813.4 )

Volume	Invert	Avail.Storage	Storage Description
#1	837.70'	13.109 af	<b>Custom Stage Data (Prismatic)</b> Listed below (Recalc)

Elevation (feet)	Surf.Area (acres)	Inc.Store (acre-feet)	Cum.Store (acre-feet)
837.70	0.045	0.000	0.000
844.00	1.020	3.355	3.355
845.00	1.176	1.098	4.453
846.00	1.275	1.225	5.678
848.00	1.434	2.709	8.387
850.00	1.613	3.047	11.434
851.00	1.737	1.675	13.109

Device	Routing	Invert	Outlet Devices
#1	Primary	843.60'	<b>24.0" Round Culvert</b> L= 101.0' RCP, end-section conforming to fill, Ke= 0.500 Inlet / Outlet Invert= 843.60' / 841.15' S= 0.0243 ' /' Cc= 0.900 n= 0.013 Concrete pipe, straight & clean, Flow Area= 3.14 sf
#2	Device 1	843.60'	<b>9.0" Vert. Orifice/Grate</b> C= 0.600
#3	Device 1	846.80'	<b>48.0" Horiz. Orifice/Grate</b> C= 0.600 Limited to weir flow at low heads

**17-06-05-Friendship village design**

MSE 24-hr 3 2 yr Rainfall=2.86"

Prepared by Westwood Professional Services, Inc.

Printed 6/8/2017

HydroCAD® 10.00-19 s/n 03363 © 2016 HydroCAD Software Solutions LLC

Page 9

**Primary OutFlow** Max=1.32 cfs @ 13.55 hrs HW=844.36' TW=0.00' (Dynamic Tailwater)

- ↑ 1=Culvert (Passes 1.32 cfs of 3.24 cfs potential flow)
- ↑ 2=Orifice/Grate (Orifice Controls 1.32 cfs @ 2.98 fps)
- ↑ 3=Orifice/Grate ( Controls 0.00 cfs)

**17-06-05-Friendship village design**

MSE 24-hr 3 10 yr Rainfall=4.27"

Prepared by Westwood Professional Services, Inc.  
HydroCAD® 10.00-19 s/n 03363 © 2016 HydroCAD Software Solutions LLC

Printed 6/8/2017  
Page 10

**Summary for Subcatchment 1S:**

Runoff = 6.44 cfs @ 12.17 hrs, Volume= 0.349 af, Depth= 2.70"

Runoff by SCS TR-20 method, UH=SCS, Weighted-CN, Time Span= 0.00-72.00 hrs, dt= 0.01 hrs  
MSE 24-hr 3 10 yr Rainfall=4.27"

Area (ac)	CN	Description
1.010	98	Paved parking, HSG B
0.540	61	>75% Grass cover, Good, HSG B
1.550	85	Weighted Average
0.540		34.84% Pervious Area
1.010		65.16% Impervious Area

Tc (min)	Length (feet)	Slope (ft/ft)	Velocity (ft/sec)	Capacity (cfs)	Description
10.0					Direct Entry,

**Summary for Subcatchment 2S:**

Runoff = 5.73 cfs @ 12.23 hrs, Volume= 0.366 af, Depth= 2.35"

Runoff by SCS TR-20 method, UH=SCS, Weighted-CN, Time Span= 0.00-72.00 hrs, dt= 0.01 hrs  
MSE 24-hr 3 10 yr Rainfall=4.27"

Area (ac)	CN	Description
1.010	98	Paved parking, HSG B
0.860	61	>75% Grass cover, Good, HSG B
1.870	81	Weighted Average
0.860		45.99% Pervious Area
1.010		54.01% Impervious Area

Tc (min)	Length (feet)	Slope (ft/ft)	Velocity (ft/sec)	Capacity (cfs)	Description
15.0					Direct Entry,

**Summary for Subcatchment 4S:**

Runoff = 5.99 cfs @ 12.18 hrs, Volume= 0.321 af, Depth= 1.87"

Runoff by SCS TR-20 method, UH=SCS, Weighted-CN, Time Span= 0.00-72.00 hrs, dt= 0.01 hrs  
MSE 24-hr 3 10 yr Rainfall=4.27"

Area (ac)	CN	Description
* 0.780	98	Paved parking, HSG B
1.280	61	>75% Grass cover, Good, HSG B
2.060	75	Weighted Average
1.280		62.14% Pervious Area
0.780		37.86% Impervious Area

**17-06-05-Friendship village design**

MSE 24-hr 3 10 yr Rainfall=4.27"

Prepared by Westwood Professional Services, Inc.  
HydroCAD® 10.00-19 s/n 03363 © 2016 HydroCAD Software Solutions LLC

Printed 6/8/2017

Page 11

Tc (min)	Length (feet)	Slope (ft/ft)	Velocity (ft/sec)	Capacity (cfs)	Description
10.0					<b>Direct Entry,</b>

**Summary for Subcatchment 5S:**

Runoff = 15.56 cfs @ 12.18 hrs, Volume= 0.833 af, Depth= 2.27"

Runoff by SCS TR-20 method, UH=SCS, Weighted-CN, Time Span= 0.00-72.00 hrs, dt= 0.01 hrs  
MSE 24-hr 3 10 yr Rainfall=4.27"

Area (ac)	CN	Description
1.190	98	Paved roads w/curbs & sewers, HSG B
2.200	61	>75% Grass cover, Good, HSG B
1.020	98	Water Surface, HSG B
4.410	80	Weighted Average
2.200		49.89% Pervious Area
2.210		50.11% Impervious Area

Tc (min)	Length (feet)	Slope (ft/ft)	Velocity (ft/sec)	Capacity (cfs)	Description
10.0					<b>Direct Entry,</b>

**Summary for Subcatchment 6S:**

Runoff = 12.28 cfs @ 12.23 hrs, Volume= 0.785 af, Depth= 2.35"

Runoff by SCS TR-20 method, UH=SCS, Weighted-CN, Time Span= 0.00-72.00 hrs, dt= 0.01 hrs  
MSE 24-hr 3 10 yr Rainfall=4.27"

Area (ac)	CN	Description
2.200	98	Paved parking, HSG B
1.810	61	>75% Grass cover, Good, HSG B
4.010	81	Weighted Average
1.810		45.14% Pervious Area
2.200		54.86% Impervious Area

Tc (min)	Length (feet)	Slope (ft/ft)	Velocity (ft/sec)	Capacity (cfs)	Description
15.0					<b>Direct Entry,</b>

**Summary for Reach 20R: Offsite Flows**

Inflow Area = 9.970 ac, 54.36% Impervious, Inflow Depth > 3.27" for 10 yr event  
Inflow = 2.98 cfs @ 13.25 hrs, Volume= 2.716 af  
Outflow = 2.98 cfs @ 13.26 hrs, Volume= 2.716 af, Atten= 0%, Lag= 0.6 min

**17-06-05-Friendship village design**

MSE 24-hr 3 10 yr Rainfall=4.27"

Prepared by Westwood Professional Services, Inc.  
HydroCAD® 10.00-19 s/n 03363 © 2016 HydroCAD Software Solutions LLC

Printed 6/8/2017  
Page 12

Routing by Sim-Route method, Time Span= 0.00-72.00 hrs, dt= 0.01 hrs

**Summary for Pond 1P: Infiltration Pond**

Inflow Area = 1.550 ac, 65.16% Impervious, Inflow Depth = 2.70" for 10 yr event  
 Inflow = 6.44 cfs @ 12.17 hrs, Volume= 0.349 af  
 Outflow = 0.78 cfs @ 12.72 hrs, Volume= 0.347 af, Atten= 88%, Lag= 32.7 min  
 Discarded = 0.05 cfs @ 12.72 hrs, Volume= 0.165 af  
 Primary = 0.73 cfs @ 12.72 hrs, Volume= 0.182 af

Routing by Sim-Route method, Time Span= 0.00-72.00 hrs, dt= 0.01 hrs  
 Peak Elev= 855.65' @ 12.72 hrs Surf.Area= 0.106 ac Storage= 0.199 af

Plug-Flow detention time= 747.9 min calculated for 0.347 af (99% of inflow)  
 Center-of-Mass det. time= 744.5 min ( 1,542.2 - 797.6 )

Volume	Invert	Avail.Storage	Storage Description
#1	853.00'	0.653 af	<b>Custom Stage Data (Prismatic)</b> Listed below (Recalc)
Elevation (feet)	Surf.Area (acres)	Inc.Store (acre-feet)	Cum.Store (acre-feet)
853.00	0.048	0.000	0.000
854.00	0.067	0.058	0.058
855.00	0.089	0.078	0.136
856.00	0.115	0.102	0.237
857.00	0.144	0.129	0.367
858.00	0.429	0.286	0.653

Device	Routing	Invert	Outlet Devices
#1	Primary	857.50'	<b>5.0' long x 1.0' breadth Broad-Crested Rectangular Weir</b> Head (feet) 0.20 0.40 0.60 0.80 1.00 1.20 1.40 1.60 1.80 2.00 2.50 3.00 Coef. (English) 2.69 2.72 2.75 2.85 2.98 3.08 3.20 3.28 3.31 3.30 3.31 3.32
#2	Discarded	853.00'	<b>0.450 in/hr Exfiltration over Surface area</b> Phase-In= 0.05'
#3	Primary	851.00'	<b>12.0" Round Culvert</b> L= 98.0' Ke= 0.500 Inlet / Outlet Invert= 851.00' / 850.51' S= 0.0050 '/ Cc= 0.900 n= 0.012 Concrete pipe, finished, Flow Area= 0.79 sf
#4	Device 3	854.80'	<b>6.0" Vert. Orifice/Grate</b> C= 0.600
#5	Device 3	857.50'	<b>48.0" Horiz. Orifice/Grate</b> C= 0.600 Limited to weir flow at low heads

**Discarded OutFlow** Max=0.05 cfs @ 12.72 hrs HW=855.65' (Free Discharge)

↑ **2=Exfiltration** (Exfiltration Controls 0.05 cfs)

**Primary OutFlow** Max=0.73 cfs @ 12.72 hrs HW=855.65' TW=0.00' (Dynamic Tailwater)

- ↑ **1=Broad-Crested Rectangular Weir** ( Controls 0.00 cfs)
- ↑ **3=Culvert** (Passes 0.73 cfs of 6.32 cfs potential flow)
- ↑ **4=Orifice/Grate** (Orifice Controls 0.73 cfs @ 3.72 fps)
- ↑ **5=Orifice/Grate** ( Controls 0.00 cfs)

**17-06-05-Friendship village design**

MSE 24-hr 3 10 yr Rainfall=4.27"

Prepared by Westwood Professional Services, Inc.  
HydroCAD® 10.00-19 s/n 03363 © 2016 HydroCAD Software Solutions LLC

Printed 6/8/2017  
Page 13

**Summary for Pond 2AP: Diversion Structure 2**

Inflow Area = 1.870 ac, 54.01% Impervious, Inflow Depth = 2.35" for 10 yr event  
 Inflow = 5.73 cfs @ 12.23 hrs, Volume= 0.366 af  
 Outflow = 5.73 cfs @ 12.24 hrs, Volume= 0.366 af, Atten= 0%, Lag= 0.6 min  
 Primary = 2.92 cfs @ 12.24 hrs, Volume= 0.149 af  
 Secondary = 2.81 cfs @ 12.24 hrs, Volume= 0.217 af

Routing by Sim-Route method, Time Span= 0.00-72.00 hrs, dt= 0.01 hrs  
 Peak Elev= 845.80' @ 12.24 hrs

Device	Routing	Invert	Outlet Devices
#1	Primary	844.50'	<b>12.0" Round Culvert</b> L= 4.0' Ke= 0.500 Inlet / Outlet Invert= 844.50' / 844.48' S= 0.0050 ' /' Cc= 0.900 n= 0.012 Concrete pipe, finished, Flow Area= 0.79 sf
#2	Secondary	845.10'	<b>24.0" Round Culvert</b> L= 273.0' Ke= 0.500 Inlet / Outlet Invert= 845.10' / 843.60' S= 0.0055 ' /' Cc= 0.900 n= 0.005, Flow Area= 3.14 sf

**Primary OutFlow** Max=2.92 cfs @ 12.24 hrs HW=845.80' TW=844.04' (Dynamic Tailwater)  
 ↑**1=Culvert** (Barrel Controls 2.92 cfs @ 3.74 fps)

**Secondary OutFlow** Max=2.81 cfs @ 12.24 hrs HW=845.80' TW=844.43' (Dynamic Tailwater)  
 ↑**2=Culvert** (Inlet Controls 2.81 cfs @ 2.85 fps)

**Summary for Pond 2P: MC-4500 Chamber infiltration**

Inflow Area = 1.870 ac, 54.01% Impervious, Inflow Depth = 0.96" for 10 yr event  
 Inflow = 2.92 cfs @ 12.24 hrs, Volume= 0.149 af  
 Outflow = 0.02 cfs @ 10.60 hrs, Volume= 0.121 af, Atten= 99%, Lag= 0.0 min  
 Discarded = 0.02 cfs @ 10.60 hrs, Volume= 0.121 af

Routing by Sim-Route method, Time Span= 0.00-72.00 hrs, dt= 0.01 hrs  
 Peak Elev= 845.57' @ 12.68 hrs Surf.Area= 0.052 ac Storage= 0.139 af

Plug-Flow detention time= 1,743.5 min calculated for 0.121 af (81% of inflow)  
 Center-of-Mass det. time= 1,717.8 min ( 2,464.9 - 747.1 )

Volume	Invert	Avail.Storage	Storage Description
#1A	841.75'	0.112 af	<b>28.50"W x 79.57"L x 8.00"H Field A</b> 0.416 af Overall - 0.137 af Embedded = 0.280 af x 40.0% Voids
#2A	842.75'	0.137 af	<b>ADS_StormTech MC-4500 +Cap</b> x 54 Inside #1 Effective Size= 90.4"W x 60.0"H => 26.46 sf x 4.03'L = 106.5 cf Overall Size= 100.0"W x 60.0"H x 4.33'L with 0.31' Overlap 3 Rows of 18 Chambers Cap Storage= +35.7 cf x 2 x 3 rows = 214.2 cf
		0.249 af	Total Available Storage

Storage Group A created with Chamber Wizard

**17-06-05-Friendship village design**

MSE 24-hr 3 10 yr Rainfall=4.27"

Prepared by Westwood Professional Services, Inc.  
HydroCAD® 10.00-19 s/n 03363 © 2016 HydroCAD Software Solutions LLC

Printed 6/8/2017  
Page 14

Device	Routing	Invert	Outlet Devices
#1	Discarded	841.75'	<b>0.450 in/hr Exfiltration over Surface area</b> Phase-In= 0.05'

**Discarded OutFlow** Max=0.02 cfs @ 10.60 hrs HW=841.80' (Free Discharge)  
 ↳1=Exfiltration (Exfiltration Controls 0.02 cfs)

**Summary for Pond 3AP: Diversion Structure-3**

Inflow Area = 2.280 ac, 89.91% Impervious, Inflow Depth = 3.59" for 10 yr event  
 Inflow = 9.99 cfs @ 12.22 hrs, Volume= 0.682 af  
 Outflow = 9.99 cfs @ 12.23 hrs, Volume= 0.682 af, Atten= 0%, Lag= 0.6 min  
 Primary = 0.89 cfs @ 12.23 hrs, Volume= 0.194 af  
 Secondary = 9.11 cfs @ 12.23 hrs, Volume= 0.488 af

Routing by Sim-Route method, Time Span= 0.00-72.00 hrs, dt= 0.01 hrs  
 Peak Elev= 854.04' @ 12.23 hrs

Device	Routing	Invert	Outlet Devices
#1	Primary	852.00'	<b>5.0" Round Culvert</b> L= 9.0' Ke= 0.500 Inlet / Outlet Invert= 852.00' / 851.95' S= 0.0056 '/ Cc= 0.900 n= 0.012 Concrete pipe, finished, Flow Area= 0.14 sf
#2	Secondary	852.50'	<b>24.0" Round Culvert</b> L= 25.0' RCP, sq.cut end projecting, Ke= 0.500 Inlet / Outlet Invert= 852.50' / 852.25' S= 0.0100 '/ Cc= 0.900 n= 0.012 Concrete pipe, finished, Flow Area= 3.14 sf

**Primary OutFlow** Max=0.89 cfs @ 12.23 hrs HW=854.04' TW=851.66' (Dynamic Tailwater)  
 ↳1=Culvert (Inlet Controls 0.89 cfs @ 6.51 fps)

**Secondary OutFlow** Max=9.09 cfs @ 12.23 hrs HW=854.04' TW=844.40' (Dynamic Tailwater)  
 ↳2=Culvert (Barrel Controls 9.09 cfs @ 4.85 fps)

**Summary for Pond 3P: SC-740 Chamber infiltration**

Inflow Area = 2.280 ac, 89.91% Impervious, Inflow Depth = 1.02" for 10 yr event  
 Inflow = 0.89 cfs @ 12.23 hrs, Volume= 0.194 af  
 Outflow = 0.04 cfs @ 6.87 hrs, Volume= 0.193 af, Atten= 96%, Lag= 0.0 min  
 Discarded = 0.04 cfs @ 6.87 hrs, Volume= 0.193 af

Routing by Sim-Route method, Time Span= 0.00-72.00 hrs, dt= 0.01 hrs  
 Peak Elev= 852.72' @ 14.50 hrs Surf.Area= 0.078 ac Storage= 0.150 af

Plug-Flow detention time= 1,605.8 min calculated for 0.193 af (100% of inflow)  
 Center-of-Mass det. time= 1,603.1 min ( 2,335.8 - 732.7 )

Volume	Invert	Avail.Storage	Storage Description
#1A	849.70'	0.102 af	<b>20.50'W x 166.20'L x 4.50'H Field A</b> 0.352 af Overall - 0.097 af Embedded = 0.255 af x 40.0% Voids
#2A	850.70'	0.097 af	<b>ADS StormTech SC-740</b> x 92 Inside #1 Effective Size= 44.6"W x 30.0"H => 6.45 sf x 7.12'L = 45.9 cf Overall Size= 51.0"W x 30.0"H x 7.56'L with 0.44' Overlap Row Length Adjustment= +0.44' x 6.45 sf x 4 rows

**17-06-05-Friendship village design**

MSE 24-hr 3 10 yr Rainfall=4.27"

Prepared by Westwood Professional Services, Inc.

Printed 6/8/2017

HydroCAD® 10.00-19 s/n 03363 © 2016 HydroCAD Software Solutions LLC

Page 15

0.199 af Total Available Storage

Storage Group A created with Chamber Wizard

Device	Routing	Invert	Outlet Devices
#1	Discarded	849.70'	<b>0.450 in/hr Exfiltration over Surface area</b> Phase-In= 0.05'

**Discarded OutFlow** Max=0.04 cfs @ 6.87 hrs HW=849.75' (Free Discharge)↑**1=Exfiltration** (Exfiltration Controls 0.04 cfs)**Summary for Pond 4AP: Diversion Structure 4**

Inflow Area = 2.060 ac, 37.86% Impervious, Inflow Depth = 1.87" for 10 yr event  
 Inflow = 5.99 cfs @ 12.18 hrs, Volume= 0.321 af  
 Outflow = 5.99 cfs @ 12.19 hrs, Volume= 0.321 af, Atten= 0%, Lag= 0.6 min  
 Primary = 0.06 cfs @ 12.19 hrs, Volume= 0.050 af  
 Secondary = 5.93 cfs @ 12.19 hrs, Volume= 0.271 af

Routing by Sim-Route method, Time Span= 0.00-72.00 hrs, dt= 0.01 hrs

Peak Elev= 847.31' @ 12.19 hrs

Device	Routing	Invert	Outlet Devices
#1	Primary	845.25'	<b>2.0" Round Culvert</b> L= 50.0' Ke= 0.500 Inlet / Outlet Invert= 845.25' / 845.00' S= 0.0050 ' /' Cc= 0.900 n= 0.012 Concrete pipe, finished, Flow Area= 0.02 sf
#2	Secondary	846.25'	<b>24.0" Round Culvert</b> L= 50.0' Ke= 0.500 Inlet / Outlet Invert= 846.25' / 843.75' S= 0.0500 ' /' Cc= 0.900 n= 0.012 Concrete pipe, finished, Flow Area= 3.14 sf

**Primary OutFlow** Max=0.06 cfs @ 12.19 hrs HW=847.31' TW=845.07' (Dynamic Tailwater)↑**1=Culvert** (Barrel Controls 0.06 cfs @ 2.93 fps)**Secondary OutFlow** Max=5.93 cfs @ 12.19 hrs HW=847.31' TW=844.26' (Dynamic Tailwater)↑**2=Culvert** (Inlet Controls 5.93 cfs @ 3.51 fps)**Summary for Pond 4P: SC-740 Chamber filtration**

Inflow Area = 2.060 ac, 37.86% Impervious, Inflow Depth = 0.29" for 10 yr event  
 Inflow = 0.06 cfs @ 12.19 hrs, Volume= 0.050 af  
 Outflow = 0.05 cfs @ 11.64 hrs, Volume= 0.050 af, Atten= 25%, Lag= 0.0 min  
 Discarded = 0.05 cfs @ 11.64 hrs, Volume= 0.050 af

Routing by Sim-Route method, Time Span= 0.00-72.00 hrs, dt= 0.01 hrs

Peak Elev= 845.14' @ 15.23 hrs Surf.Area= 0.029 ac Storage= 0.002 af

Plug-Flow detention time= 19.2 min calculated for 0.050 af (100% of inflow)

Center-of-Mass det. time= 19.2 min ( 1,043.3 - 1,024.1 )

**17-06-05-Friendship village design**

MSE 24-hr 3 10 yr Rainfall=4.27"

Prepared by Westwood Professional Services, Inc.  
HydroCAD® 10.00-19 s/n 03363 © 2016 HydroCAD Software Solutions LLC

Printed 6/8/2017  
Page 16

Volume	Invert	Avail.Storage	Storage Description
#1A	845.00'	0.033 af	<b>15.75'W x 80.76'L x 4.00'H Field A</b> 0.117 af Overall - 0.035 af Embedded = 0.082 af x 40.0% Voids
#2A	846.00'	0.035 af	<b>ADS_StormTech SC-740</b> x 33 Inside #1 Effective Size= 44.6"W x 30.0"H => 6.45 sf x 7.12'L = 45.9 cf Overall Size= 51.0"W x 30.0"H x 7.56'L with 0.44' Overlap Row Length Adjustment= +0.44' x 6.45 sf x 3 rows
		0.068 af	Total Available Storage

Storage Group A created with Chamber Wizard

Device	Routing	Invert	Outlet Devices
#1	Discarded	845.00'	<b>1.630 in/hr Exfiltration over Surface area</b> Phase-In= 0.05'

**Discarded OutFlow** Max=0.05 cfs @ 11.64 hrs HW=845.05' (Free Discharge)  
 ↑ **1=Exfiltration** (Exfiltration Controls 0.05 cfs)

**Summary for Pond 22P: Proposed Pond - Revised Existing Pond**

Inflow Area = 8.420 ac, 52.38% Impervious, Inflow Depth = 3.70" for 10 yr event  
 Inflow = 43.85 cfs @ 12.20 hrs, Volume= 2.594 af  
 Outflow = 2.32 cfs @ 13.70 hrs, Volume= 2.534 af, Atten= 95%, Lag= 89.6 min  
 Primary = 2.32 cfs @ 13.70 hrs, Volume= 2.534 af

Routing by Sim-Route method, Time Span= 0.00-72.00 hrs, dt= 0.01 hrs  
 Starting Elev= 843.60' Surf.Area= 0.958 ac Storage= 2.959 af  
 Peak Elev= 845.17' @ 13.70 hrs Surf.Area= 1.193 ac Storage= 4.651 af (1.692 af above start)

Plug-Flow detention time= (not calculated: initial storage exceeds outflow)  
 Center-of-Mass det. time= 476.9 min ( 1,284.4 - 807.5 )

Volume	Invert	Avail.Storage	Storage Description
#1	837.70'	13.109 af	<b>Custom Stage Data (Prismatic)</b> Listed below (Recalc)

Elevation (feet)	Surf.Area (acres)	Inc.Store (acre-feet)	Cum.Store (acre-feet)
837.70	0.045	0.000	0.000
844.00	1.020	3.355	3.355
845.00	1.176	1.098	4.453
846.00	1.275	1.225	5.678
848.00	1.434	2.709	8.387
850.00	1.613	3.047	11.434
851.00	1.737	1.675	13.109

Device	Routing	Invert	Outlet Devices
#1	Primary	843.60'	<b>24.0" Round Culvert</b> L= 101.0' RCP, end-section conforming to fill, Ke= 0.500 Inlet / Outlet Invert= 843.60' / 841.15' S= 0.0243 ' /' Cc= 0.900 n= 0.013 Concrete pipe, straight & clean, Flow Area= 3.14 sf
#2	Device 1	843.60'	<b>9.0" Vert. Orifice/Grate</b> C= 0.600
#3	Device 1	846.80'	<b>48.0" Horiz. Orifice/Grate</b> C= 0.600 Limited to weir flow at low heads

**17-06-05-Friendship village design**

MSE 24-hr 3 10 yr Rainfall=4.27"

Prepared by Westwood Professional Services, Inc.

Printed 6/8/2017

HydroCAD® 10.00-19 s/n 03363 © 2016 HydroCAD Software Solutions LLC

Page 17

**Primary OutFlow** Max=2.32 cfs @ 13.70 hrs HW=845.17' TW=0.00' (Dynamic Tailwater)

↑ **1=Culvert** (Passes 2.32 cfs of 11.26 cfs potential flow)

↑ **2=Orifice/Grate** (Orifice Controls 2.32 cfs @ 5.26 fps)

↑ **3=Orifice/Grate** ( Controls 0.00 cfs)

**17-06-05-Friendship village design**

MSE 24-hr 3 100 yr Rainfall=7.46"

Prepared by Westwood Professional Services, Inc.

Printed 6/8/2017

HydroCAD® 10.00-19 s/n 03363 © 2016 HydroCAD Software Solutions LLC

Page 18

**Summary for Subcatchment 1S:**

Runoff = 13.12 cfs @ 12.17 hrs, Volume= 0.735 af, Depth= 5.69"

Runoff by SCS TR-20 method, UH=SCS, Weighted-CN, Time Span= 0.00-72.00 hrs, dt= 0.01 hrs  
MSE 24-hr 3 100 yr Rainfall=7.46"

Area (ac)	CN	Description
1.010	98	Paved parking, HSG B
0.540	61	>75% Grass cover, Good, HSG B
1.550	85	Weighted Average
0.540		34.84% Pervious Area
1.010		65.16% Impervious Area

Tc (min)	Length (feet)	Slope (ft/ft)	Velocity (ft/sec)	Capacity (cfs)	Description
10.0					Direct Entry,

**Summary for Subcatchment 2S:**

Runoff = 12.52 cfs @ 12.23 hrs, Volume= 0.816 af, Depth= 5.23"

Runoff by SCS TR-20 method, UH=SCS, Weighted-CN, Time Span= 0.00-72.00 hrs, dt= 0.01 hrs  
MSE 24-hr 3 100 yr Rainfall=7.46"

Area (ac)	CN	Description
1.010	98	Paved parking, HSG B
0.860	61	>75% Grass cover, Good, HSG B
1.870	81	Weighted Average
0.860		45.99% Pervious Area
1.010		54.01% Impervious Area

Tc (min)	Length (feet)	Slope (ft/ft)	Velocity (ft/sec)	Capacity (cfs)	Description
15.0					Direct Entry,

**Summary for Subcatchment 4S:**

Runoff = 14.49 cfs @ 12.18 hrs, Volume= 0.782 af, Depth= 4.56"

Runoff by SCS TR-20 method, UH=SCS, Weighted-CN, Time Span= 0.00-72.00 hrs, dt= 0.01 hrs  
MSE 24-hr 3 100 yr Rainfall=7.46"

Area (ac)	CN	Description
* 0.780	98	Paved parking, HSG B
1.280	61	>75% Grass cover, Good, HSG B
2.060	75	Weighted Average
1.280		62.14% Pervious Area
0.780		37.86% Impervious Area

**17-06-05-Friendship village design**

MSE 24-hr 3 100 yr Rainfall=7.46"

Prepared by Westwood Professional Services, Inc.  
 HydroCAD® 10.00-19 s/n 03363 © 2016 HydroCAD Software Solutions LLC

Printed 6/8/2017  
 Page 19

Tc (min)	Length (feet)	Slope (ft/ft)	Velocity (ft/sec)	Capacity (cfs)	Description
10.0					<b>Direct Entry,</b>

**Summary for Subcatchment 5S:**

Runoff = 34.36 cfs @ 12.17 hrs, Volume= 1.882 af, Depth= 5.12"

Runoff by SCS TR-20 method, UH=SCS, Weighted-CN, Time Span= 0.00-72.00 hrs, dt= 0.01 hrs  
 MSE 24-hr 3 100 yr Rainfall=7.46"

Area (ac)	CN	Description
1.190	98	Paved roads w/curbs & sewers, HSG B
2.200	61	>75% Grass cover, Good, HSG B
1.020	98	Water Surface, HSG B
4.410	80	Weighted Average
2.200		49.89% Pervious Area
2.210		50.11% Impervious Area

Tc (min)	Length (feet)	Slope (ft/ft)	Velocity (ft/sec)	Capacity (cfs)	Description
10.0					<b>Direct Entry,</b>

**Summary for Subcatchment 6S:**

Runoff = 26.84 cfs @ 12.23 hrs, Volume= 1.749 af, Depth= 5.23"

Runoff by SCS TR-20 method, UH=SCS, Weighted-CN, Time Span= 0.00-72.00 hrs, dt= 0.01 hrs  
 MSE 24-hr 3 100 yr Rainfall=7.46"

Area (ac)	CN	Description
2.200	98	Paved parking, HSG B
1.810	61	>75% Grass cover, Good, HSG B
4.010	81	Weighted Average
1.810		45.14% Pervious Area
2.200		54.86% Impervious Area

Tc (min)	Length (feet)	Slope (ft/ft)	Velocity (ft/sec)	Capacity (cfs)	Description
15.0					<b>Direct Entry,</b>

**Summary for Reach 20R: Offsite Flows**

Inflow Area = 9.970 ac, 54.36% Impervious, Inflow Depth > 7.85" for 100 yr event  
 Inflow = 8.86 cfs @ 13.43 hrs, Volume= 6.522 af  
 Outflow = 8.86 cfs @ 13.44 hrs, Volume= 6.522 af, Atten= 0%, Lag= 0.6 min

**17-06-05-Friendship village design**

MSE 24-hr 3 100 yr Rainfall=7.46"

Prepared by Westwood Professional Services, Inc.

Printed 6/8/2017

HydroCAD® 10.00-19 s/n 03363 © 2016 HydroCAD Software Solutions LLC

Page 20

Routing by Sim-Route method, Time Span= 0.00-72.00 hrs, dt= 0.01 hrs

**Summary for Pond 1P: Infiltration Pond**

Inflow Area = 1.550 ac, 65.16% Impervious, Inflow Depth = 5.69" for 100 yr event  
 Inflow = 13.12 cfs @ 12.17 hrs, Volume= 0.735 af  
 Outflow = 1.53 cfs @ 12.71 hrs, Volume= 0.731 af, Atten= 88%, Lag= 32.0 min  
 Discarded = 0.11 cfs @ 12.71 hrs, Volume= 0.183 af  
 Primary = 1.43 cfs @ 12.71 hrs, Volume= 0.549 af

Routing by Sim-Route method, Time Span= 0.00-72.00 hrs, dt= 0.01 hrs  
 Peak Elev= 857.32' @ 12.71 hrs Surf.Area= 0.236 ac Storage= 0.428 af

Plug-Flow detention time= 432.1 min calculated for 0.731 af (99% of inflow)  
 Center-of-Mass det. time= 428.7 min ( 1,211.5 - 782.8 )

Volume	Invert	Avail.Storage	Storage Description
#1	853.00'	0.653 af	<b>Custom Stage Data (Prismatic)</b> Listed below (Recalc)
Elevation (feet)	Surf.Area (acres)	Inc.Store (acre-feet)	Cum.Store (acre-feet)
853.00	0.048	0.000	0.000
854.00	0.067	0.058	0.058
855.00	0.089	0.078	0.136
856.00	0.115	0.102	0.237
857.00	0.144	0.129	0.367
858.00	0.429	0.286	0.653

Device	Routing	Invert	Outlet Devices
#1	Primary	857.50'	<b>5.0' long x 1.0' breadth Broad-Crested Rectangular Weir</b> Head (feet) 0.20 0.40 0.60 0.80 1.00 1.20 1.40 1.60 1.80 2.00 2.50 3.00 Coef. (English) 2.69 2.72 2.75 2.85 2.98 3.08 3.20 3.28 3.31 3.30 3.31 3.32
#2	Discarded	853.00'	<b>0.450 in/hr Exfiltration over Surface area</b> Phase-In= 0.05'
#3	Primary	851.00'	<b>12.0" Round Culvert</b> L= 98.0' Ke= 0.500 Inlet / Outlet Invert= 851.00' / 850.51' S= 0.0050 '/ Cc= 0.900 n= 0.012 Concrete pipe, finished, Flow Area= 0.79 sf
#4	Device 3	854.80'	<b>6.0" Vert. Orifice/Grate</b> C= 0.600
#5	Device 3	857.50'	<b>48.0" Horiz. Orifice/Grate</b> C= 0.600 Limited to weir flow at low heads

**Discarded OutFlow** Max=0.11 cfs @ 12.71 hrs HW=857.32' (Free Discharge)

↑ **2=Exfiltration** (Exfiltration Controls 0.11 cfs)

**Primary OutFlow** Max=1.43 cfs @ 12.71 hrs HW=857.32' TW=0.00' (Dynamic Tailwater)

↑ **1=Broad-Crested Rectangular Weir** ( Controls 0.00 cfs)  
 ↑ **3=Culvert** (Passes 1.43 cfs of 7.48 cfs potential flow)  
 ↑ **4=Orifice/Grate** (Orifice Controls 1.43 cfs @ 7.26 fps)  
 ↑ **5=Orifice/Grate** ( Controls 0.00 cfs)

**17-06-05-Friendship village design**

MSE 24-hr 3 100 yr Rainfall=7.46"

Prepared by Westwood Professional Services, Inc.  
HydroCAD® 10.00-19 s/n 03363 © 2016 HydroCAD Software Solutions LLC

Printed 6/8/2017  
Page 21

**Summary for Pond 2AP: Diversion Structure 2**

Inflow Area = 1.870 ac, 54.01% Impervious, Inflow Depth = 5.23" for 100 yr event  
 Inflow = 12.52 cfs @ 12.23 hrs, Volume= 0.816 af  
 Outflow = 12.52 cfs @ 12.24 hrs, Volume= 0.816 af, Atten= 0%, Lag= 0.6 min  
 Primary = 2.96 cfs @ 12.09 hrs, Volume= 0.200 af  
 Secondary = 10.28 cfs @ 12.26 hrs, Volume= 0.616 af

Routing by Sim-Route method, Time Span= 0.00-72.00 hrs, dt= 0.01 hrs  
 Peak Elev= 847.01' @ 13.42 hrs

Device	Routing	Invert	Outlet Devices
#1	Primary	844.50'	<b>12.0" Round Culvert</b> L= 4.0' Ke= 0.500 Inlet / Outlet Invert= 844.50' / 844.48' S= 0.0050 ' /' Cc= 0.900 n= 0.012 Concrete pipe, finished, Flow Area= 0.79 sf
#2	Secondary	845.10'	<b>24.0" Round Culvert</b> L= 273.0' Ke= 0.500 Inlet / Outlet Invert= 845.10' / 843.60' S= 0.0055 ' /' Cc= 0.900 n= 0.005, Flow Area= 3.14 sf

**Primary OutFlow** Max=2.82 cfs @ 12.09 hrs HW=845.86' TW=845.31' (Dynamic Tailwater)  
 ↑**1=Culvert** (Inlet Controls 2.82 cfs @ 3.59 fps)

**Secondary OutFlow** Max=9.95 cfs @ 12.26 hrs HW=846.60' TW=845.69' (Dynamic Tailwater)  
 ↑**2=Culvert** (Outlet Controls 9.95 cfs @ 5.47 fps)

**Summary for Pond 2P: MC-4500 Chamber infiltration**

Inflow Area = 1.870 ac, 54.01% Impervious, Inflow Depth = 1.28" for 100 yr event  
 Inflow = 2.96 cfs @ 12.09 hrs, Volume= 0.200 af  
 Outflow = 0.02 cfs @ 8.46 hrs, Volume= 0.125 af, Atten= 99%, Lag= 0.0 min  
 Discarded = 0.02 cfs @ 8.46 hrs, Volume= 0.125 af

Routing by Sim-Route method, Time Span= 0.00-72.00 hrs, dt= 0.01 hrs  
 Peak Elev= 847.01' @ 13.40 hrs Surf.Area= 0.052 ac Storage= 0.189 af

Plug-Flow detention time= 1,723.9 min calculated for 0.125 af (63% of inflow)  
 Center-of-Mass det. time= 1,700.5 min ( 2,397.3 - 696.8 )

Volume	Invert	Avail.Storage	Storage Description
#1A	841.75'	0.112 af	<b>28.50"W x 79.57"L x 8.00"H Field A</b> 0.416 af Overall - 0.137 af Embedded = 0.280 af x 40.0% Voids
#2A	842.75'	0.137 af	<b>ADS_StormTech MC-4500 +Cap</b> x 54 Inside #1 Effective Size= 90.4"W x 60.0"H => 26.46 sf x 4.03'L = 106.5 cf Overall Size= 100.0"W x 60.0"H x 4.33'L with 0.31' Overlap 3 Rows of 18 Chambers Cap Storage= +35.7 cf x 2 x 3 rows = 214.2 cf
		0.249 af	Total Available Storage

Storage Group A created with Chamber Wizard

**17-06-05-Friendship village design**

MSE 24-hr 3 100 yr Rainfall=7.46"

Prepared by Westwood Professional Services, Inc.

Printed 6/8/2017

HydroCAD® 10.00-19 s/n 03363 © 2016 HydroCAD Software Solutions LLC

Page 22

Device	Routing	Invert	Outlet Devices
#1	Discarded	841.75'	<b>0.450 in/hr Exfiltration over Surface area</b> Phase-In= 0.05'

**Discarded OutFlow** Max=0.02 cfs @ 8.46 hrs HW=841.80' (Free Discharge)

↑1=Exfiltration (Exfiltration Controls 0.02 cfs)

**Summary for Pond 3AP: Diversion Structure-3**

Inflow Area = 2.280 ac, 89.91% Impervious, Inflow Depth = 6.75" for 100 yr event  
 Inflow = 18.14 cfs @ 12.22 hrs, Volume= 1.282 af  
 Outflow = 18.14 cfs @ 12.23 hrs, Volume= 1.282 af, Atten= 0%, Lag= 0.6 min  
 Primary = 0.95 cfs @ 12.23 hrs, Volume= 0.201 af  
 Secondary = 17.20 cfs @ 12.23 hrs, Volume= 1.081 af

Routing by Sim-Route method, Time Span= 0.00-72.00 hrs, dt= 0.01 hrs  
 Peak Elev= 854.95' @ 12.23 hrs

Device	Routing	Invert	Outlet Devices
#1	Primary	852.00'	<b>5.0" Round Culvert</b> L= 9.0' Ke= 0.500 Inlet / Outlet Invert= 852.00' / 851.95' S= 0.0056 ' Cc= 0.900 n= 0.012 Concrete pipe, finished, Flow Area= 0.14 sf
#2	Secondary	852.50'	<b>24.0" Round Culvert</b> L= 25.0' RCP, sq.cut end projecting, Ke= 0.500 Inlet / Outlet Invert= 852.50' / 852.25' S= 0.0100 ' Cc= 0.900 n= 0.012 Concrete pipe, finished, Flow Area= 3.14 sf

**Primary OutFlow** Max=0.94 cfs @ 12.23 hrs HW=854.94' TW=852.88' (Dynamic Tailwater)

↑1=Culvert (Inlet Controls 0.94 cfs @ 6.91 fps)

**Secondary OutFlow** Max=17.18 cfs @ 12.23 hrs HW=854.95' TW=845.56' (Dynamic Tailwater)

↑2=Culvert (Barrel Controls 17.18 cfs @ 5.69 fps)

**Summary for Pond 3P: SC-740 Chamber infiltration**

Inflow Area = 2.280 ac, 89.91% Impervious, Inflow Depth = 1.06" for 100 yr event  
 Inflow = 0.95 cfs @ 12.23 hrs, Volume= 0.201 af  
 Outflow = 0.04 cfs @ 4.81 hrs, Volume= 0.199 af, Atten= 96%, Lag= 0.0 min  
 Discarded = 0.04 cfs @ 4.81 hrs, Volume= 0.199 af

Routing by Sim-Route method, Time Span= 0.00-72.00 hrs, dt= 0.01 hrs  
 Peak Elev= 853.42' @ 12.65 hrs Surf.Area= 0.078 ac Storage= 0.175 af

Plug-Flow detention time= 1,688.9 min calculated for 0.199 af (99% of inflow)

Center-of-Mass det. time= 1,683.0 min ( 2,287.0 - 604.1 )

Volume	Invert	Avail.Storage	Storage Description
#1A	849.70'	0.102 af	<b>20.50'W x 166.20'L x 4.50'H Field A</b> 0.352 af Overall - 0.097 af Embedded = 0.255 af x 40.0% Voids
#2A	850.70'	0.097 af	<b>ADS StormTech SC-740</b> x 92 Inside #1 Effective Size= 44.6"W x 30.0"H => 6.45 sf x 7.12'L = 45.9 cf Overall Size= 51.0"W x 30.0"H x 7.56'L with 0.44' Overlap Row Length Adjustment= +0.44' x 6.45 sf x 4 rows

**17-06-05-Friendship village design**

MSE 24-hr 3 100 yr Rainfall=7.46"

Prepared by Westwood Professional Services, Inc.

Printed 6/8/2017

HydroCAD® 10.00-19 s/n 03363 © 2016 HydroCAD Software Solutions LLC

Page 23

0.199 af Total Available Storage

Storage Group A created with Chamber Wizard

Device	Routing	Invert	Outlet Devices
#1	Discarded	849.70'	<b>0.450 in/hr Exfiltration over Surface area</b> Phase-In= 0.05'

**Discarded OutFlow** Max=0.04 cfs @ 4.81 hrs HW=849.75' (Free Discharge)↑**1=Exfiltration** (Exfiltration Controls 0.04 cfs)**Summary for Pond 4AP: Diversion Structure 4**

Inflow Area = 2.060 ac, 37.86% Impervious, Inflow Depth = 4.56" for 100 yr event  
 Inflow = 14.49 cfs @ 12.18 hrs, Volume= 0.782 af  
 Outflow = 14.49 cfs @ 12.19 hrs, Volume= 0.782 af, Atten= 0%, Lag= 0.6 min  
 Primary = 0.08 cfs @ 12.19 hrs, Volume= 0.062 af  
 Secondary = 14.42 cfs @ 12.19 hrs, Volume= 0.720 af

Routing by Sim-Route method, Time Span= 0.00-72.00 hrs, dt= 0.01 hrs

Peak Elev= 848.14' @ 12.19 hrs

Device	Routing	Invert	Outlet Devices
#1	Primary	845.25'	<b>2.0" Round Culvert</b> L= 50.0' Ke= 0.500 Inlet / Outlet Invert= 845.25' / 845.00' S= 0.0050 ' Cc= 0.900 n= 0.012 Concrete pipe, finished, Flow Area= 0.02 sf
#2	Secondary	846.25'	<b>24.0" Round Culvert</b> L= 50.0' Ke= 0.500 Inlet / Outlet Invert= 846.25' / 843.75' S= 0.0500 ' Cc= 0.900 n= 0.012 Concrete pipe, finished, Flow Area= 3.14 sf

**Primary OutFlow** Max=0.08 cfs @ 12.19 hrs HW=848.14' TW=845.12' (Dynamic Tailwater)↑**1=Culvert** (Barrel Controls 0.08 cfs @ 3.45 fps)**Secondary OutFlow** Max=14.40 cfs @ 12.19 hrs HW=848.14' TW=845.25' (Dynamic Tailwater)↑**2=Culvert** (Inlet Controls 14.40 cfs @ 4.68 fps)**Summary for Pond 4P: SC-740 Chamber filtration**

Inflow Area = 2.060 ac, 37.86% Impervious, Inflow Depth = 0.36" for 100 yr event  
 Inflow = 0.08 cfs @ 12.19 hrs, Volume= 0.062 af  
 Outflow = 0.05 cfs @ 10.68 hrs, Volume= 0.062 af, Atten= 36%, Lag= 0.0 min  
 Discarded = 0.05 cfs @ 10.68 hrs, Volume= 0.062 af

Routing by Sim-Route method, Time Span= 0.00-72.00 hrs, dt= 0.01 hrs

Peak Elev= 845.39' @ 17.78 hrs Surf.Area= 0.029 ac Storage= 0.005 af

Plug-Flow detention time= 46.2 min calculated for 0.062 af (100% of inflow)

Center-of-Mass det. time= 46.2 min ( 1,024.0 - 977.8 )

**17-06-05-Friendship village design**

MSE 24-hr 3 100 yr Rainfall=7.46"

Prepared by Westwood Professional Services, Inc.  
HydroCAD® 10.00-19 s/n 03363 © 2016 HydroCAD Software Solutions LLC

Printed 6/8/2017

Page 24

Volume	Invert	Avail.Storage	Storage Description
#1A	845.00'	0.033 af	<b>15.75'W x 80.76'L x 4.00'H Field A</b> 0.117 af Overall - 0.035 af Embedded = 0.082 af x 40.0% Voids
#2A	846.00'	0.035 af	<b>ADS_StormTech SC-740</b> x 33 Inside #1 Effective Size= 44.6"W x 30.0"H => 6.45 sf x 7.12'L = 45.9 cf Overall Size= 51.0"W x 30.0"H x 7.56'L with 0.44' Overlap Row Length Adjustment= +0.44' x 6.45 sf x 3 rows
		0.068 af	Total Available Storage

Storage Group A created with Chamber Wizard

Device	Routing	Invert	Outlet Devices
#1	Discarded	845.00'	<b>1.630 in/hr Exfiltration over Surface area</b> Phase-In= 0.05'

**Discarded OutFlow** Max=0.05 cfs @ 10.68 hrs HW=845.05' (Free Discharge)

↑**1=Exfiltration** (Exfiltration Controls 0.05 cfs)

**Summary for Pond 22P: Proposed Pond - Revised Existing Pond**

Inflow Area = 8.420 ac, 52.38% Impervious, Inflow Depth = 8.62" for 100 yr event  
 Inflow = 98.58 cfs @ 12.20 hrs, Volume= 6.048 af  
 Outflow = 7.47 cfs @ 13.43 hrs, Volume= 5.973 af, Atten= 92%, Lag= 73.9 min  
 Primary = 7.47 cfs @ 13.43 hrs, Volume= 5.973 af

Routing by Sim-Route method, Time Span= 0.00-72.00 hrs, dt= 0.01 hrs  
 Starting Elev= 843.60' Surf.Area= 0.958 ac Storage= 2.959 af  
 Peak Elev= 847.00' @ 13.43 hrs Surf.Area= 1.355 ac Storage= 6.998 af (4.038 af above start)

Plug-Flow detention time= 1,049.8 min calculated for 3.014 af (50% of inflow)  
 Center-of-Mass det. time= 568.0 min ( 1,364.2 - 796.2 )

Volume	Invert	Avail.Storage	Storage Description
#1	837.70'	13.109 af	<b>Custom Stage Data (Prismatic)</b> Listed below (Recalc)

Elevation (feet)	Surf.Area (acres)	Inc.Store (acre-feet)	Cum.Store (acre-feet)
837.70	0.045	0.000	0.000
844.00	1.020	3.355	3.355
845.00	1.176	1.098	4.453
846.00	1.275	1.225	5.678
848.00	1.434	2.709	8.387
850.00	1.613	3.047	11.434
851.00	1.737	1.675	13.109

Device	Routing	Invert	Outlet Devices
#1	Primary	843.60'	<b>24.0" Round Culvert</b> L= 101.0' RCP, end-section conforming to fill, Ke= 0.500 Inlet / Outlet Invert= 843.60' / 841.15' S= 0.0243 ' / Cc= 0.900 n= 0.013 Concrete pipe, straight & clean, Flow Area= 3.14 sf
#2	Device 1	843.60'	<b>9.0" Vert. Orifice/Grate</b> C= 0.600
#3	Device 1	846.80'	<b>48.0" Horiz. Orifice/Grate</b> C= 0.600 Limited to weir flow at low heads

**17-06-05-Friendship village design**

MSE 24-hr 3 100 yr Rainfall=7.46"

Prepared by Westwood Professional Services, Inc.

Printed 6/8/2017

HydroCAD® 10.00-19 s/n 03363 © 2016 HydroCAD Software Solutions LLC

Page 25

**Primary OutFlow** Max=7.47 cfs @ 13.43 hrs HW=847.00' TW=0.00' (Dynamic Tailwater)

↑ **1=Culvert** (Passes 7.47 cfs of 23.45 cfs potential flow)

↑ **2=Orifice/Grate** (Orifice Controls 3.70 cfs @ 8.38 fps)

↑ **3=Orifice/Grate** (Weir Controls 3.77 cfs @ 1.47 fps)

**17-06-05-Friendship village design**

MSE 24-hr 3 100 yr back to back Rainfall=7.46" x 2

Prepared by Westwood Professional Services, Inc.

Printed 6/8/2017

HydroCAD® 10.00-19 s/n 03363 © 2016 HydroCAD Software Solutions LLC

Page 26

**Summary for Subcatchment 1S:**

Runoff = 14.53 cfs @ 36.17 hrs, Volume= 1.678 af, Depth=12.99"

Runoff by SCS TR-20 method, UH=SCS, Weighted-CN, Time Span= 0.00-72.00 hrs, dt= 0.01 hrs  
MSE 24-hr 3 100 yr back to back Rainfall=7.46" x 2

Area (ac)	CN	Description
1.010	98	Paved parking, HSG B
0.540	61	>75% Grass cover, Good, HSG B
1.550	85	Weighted Average
0.540		34.84% Pervious Area
1.010		65.16% Impervious Area

Tc (min)	Length (feet)	Slope (ft/ft)	Velocity (ft/sec)	Capacity (cfs)	Description
10.0					Direct Entry,

**Summary for Subcatchment 2S:**

Runoff = 14.75 cfs @ 36.22 hrs, Volume= 1.937 af, Depth=12.43"

Runoff by SCS TR-20 method, UH=SCS, Weighted-CN, Time Span= 0.00-72.00 hrs, dt= 0.01 hrs  
MSE 24-hr 3 100 yr back to back Rainfall=7.46" x 2

Area (ac)	CN	Description
1.010	98	Paved parking, HSG B
0.860	61	>75% Grass cover, Good, HSG B
1.870	81	Weighted Average
0.860		45.99% Pervious Area
1.010		54.01% Impervious Area

Tc (min)	Length (feet)	Slope (ft/ft)	Velocity (ft/sec)	Capacity (cfs)	Description
15.0					Direct Entry,

**Summary for Subcatchment 4S:**

Runoff = 18.57 cfs @ 36.17 hrs, Volume= 1.983 af, Depth=11.55"

Runoff by SCS TR-20 method, UH=SCS, Weighted-CN, Time Span= 0.00-72.00 hrs, dt= 0.01 hrs  
MSE 24-hr 3 100 yr back to back Rainfall=7.46" x 2

Area (ac)	CN	Description
* 0.780	98	Paved parking, HSG B
1.280	61	>75% Grass cover, Good, HSG B
2.060	75	Weighted Average
1.280		62.14% Pervious Area
0.780		37.86% Impervious Area

**17-06-05-Friendship village design**

MSE 24-hr 3 100 yr back to back Rainfall=7.46" x 2

Prepared by Westwood Professional Services, Inc.

Printed 6/8/2017

HydroCAD® 10.00-19 s/n 03363 © 2016 HydroCAD Software Solutions LLC

Page 27

Tc (min)	Length (feet)	Slope (ft/ft)	Velocity (ft/sec)	Capacity (cfs)	Description
10.0					<b>Direct Entry,</b>

**Summary for Subcatchment 5S:**

Runoff = 40.67 cfs @ 36.17 hrs, Volume= 4.516 af, Depth=12.29"

Runoff by SCS TR-20 method, UH=SCS, Weighted-CN, Time Span= 0.00-72.00 hrs, dt= 0.01 hrs  
MSE 24-hr 3 100 yr back to back Rainfall=7.46" x 2

Area (ac)	CN	Description
1.190	98	Paved roads w/curbs & sewers, HSG B
2.200	61	>75% Grass cover, Good, HSG B
1.020	98	Water Surface, HSG B
4.410	80	Weighted Average
2.200		49.89% Pervious Area
2.210		50.11% Impervious Area

Tc (min)	Length (feet)	Slope (ft/ft)	Velocity (ft/sec)	Capacity (cfs)	Description
10.0					<b>Direct Entry,</b>

**Summary for Subcatchment 6S:**

Runoff = 31.63 cfs @ 36.22 hrs, Volume= 4.155 af, Depth=12.43"

Runoff by SCS TR-20 method, UH=SCS, Weighted-CN, Time Span= 0.00-72.00 hrs, dt= 0.01 hrs  
MSE 24-hr 3 100 yr back to back Rainfall=7.46" x 2

Area (ac)	CN	Description
2.200	98	Paved parking, HSG B
1.810	61	>75% Grass cover, Good, HSG B
4.010	81	Weighted Average
1.810		45.14% Pervious Area
2.200		54.86% Impervious Area

Tc (min)	Length (feet)	Slope (ft/ft)	Velocity (ft/sec)	Capacity (cfs)	Description
15.0					<b>Direct Entry,</b>

**Summary for Reach 20R: Offsite Flows**

Inflow Area = 9.970 ac, 54.36% Impervious, Inflow Depth > 18.99" for 100 yr back to back event  
 Inflow = 31.31 cfs @ 36.46 hrs, Volume= 15.778 af  
 Outflow = 31.31 cfs @ 36.47 hrs, Volume= 15.778 af, Atten= 0%, Lag= 0.6 min

**17-06-05-Friendship village design**

MSE 24-hr 3 100 yr back to back Rainfall=7.46" x 2

Prepared by Westwood Professional Services, Inc.

Printed 6/8/2017

HydroCAD® 10.00-19 s/n 03363 © 2016 HydroCAD Software Solutions LLC

Page 28

Routing by Sim-Route method, Time Span= 0.00-72.00 hrs, dt= 0.01 hrs

**Summary for Pond 1P: Infiltration Pond**

Inflow Area = 1.550 ac, 65.16% Impervious, Inflow Depth = 12.99" for 100 yr back to back event  
 Inflow = 14.53 cfs @ 36.17 hrs, Volume= 1.678 af  
 Outflow = 4.26 cfs @ 36.42 hrs, Volume= 1.622 af, Atten= 71%, Lag= 14.9 min  
 Discarded = 0.15 cfs @ 36.42 hrs, Volume= 0.229 af  
 Primary = 4.11 cfs @ 36.42 hrs, Volume= 1.392 af

Routing by Sim-Route method, Time Span= 0.00-72.00 hrs, dt= 0.01 hrs  
 Peak Elev= 857.63' @ 36.42 hrs Surf.Area= 0.324 ac Storage= 0.514 af

Plug-Flow detention time= 282.4 min calculated for 1.622 af (97% of inflow)  
 Center-of-Mass det. time= 244.7 min ( 1,807.2 - 1,562.6 )

Volume	Invert	Avail.Storage	Storage Description
#1	853.00'	0.653 af	<b>Custom Stage Data (Prismatic)</b> Listed below (Recalc)
Elevation (feet)	Surf.Area (acres)	Inc.Store (acre-feet)	Cum.Store (acre-feet)
853.00	0.048	0.000	0.000
854.00	0.067	0.058	0.058
855.00	0.089	0.078	0.136
856.00	0.115	0.102	0.237
857.00	0.144	0.129	0.367
858.00	0.429	0.286	0.653

Device	Routing	Invert	Outlet Devices
#1	Primary	857.50'	<b>5.0' long x 1.0' breadth Broad-Crested Rectangular Weir</b> Head (feet) 0.20 0.40 0.60 0.80 1.00 1.20 1.40 1.60 1.80 2.00 2.50 3.00 Coef. (English) 2.69 2.72 2.75 2.85 2.98 3.08 3.20 3.28 3.31 3.30 3.31 3.32
#2	Discarded	853.00'	<b>0.450 in/hr Exfiltration over Surface area</b> Phase-In= 0.05'
#3	Primary	851.00'	<b>12.0" Round Culvert</b> L= 98.0' Ke= 0.500 Inlet / Outlet Invert= 851.00' / 850.51' S= 0.0050 '/ Cc= 0.900 n= 0.012 Concrete pipe, finished, Flow Area= 0.79 sf
#4	Device 3	854.80'	<b>6.0" Vert. Orifice/Grate</b> C= 0.600
#5	Device 3	857.50'	<b>48.0" Horiz. Orifice/Grate</b> C= 0.600 Limited to weir flow at low heads

**Discarded OutFlow** Max=0.15 cfs @ 36.42 hrs HW=857.63' (Free Discharge)

↑ **2=Exfiltration** (Exfiltration Controls 0.15 cfs)

**Primary OutFlow** Max=4.11 cfs @ 36.42 hrs HW=857.63' TW=0.00' (Dynamic Tailwater)

↑ **1=Broad-Crested Rectangular Weir** (Weir Controls 0.64 cfs @ 0.97 fps)

↑ **3=Culvert** (Passes 3.47 cfs of 7.68 cfs potential flow)

↑ **4=Orifice/Grate** (Orifice Controls 1.52 cfs @ 7.74 fps)

↑ **5=Orifice/Grate** (Weir Controls 1.95 cfs @ 1.18 fps)

**17-06-05-Friendship village design**

MSE 24-hr 3 100 yr back to back Rainfall=7.46" x 2

Prepared by Westwood Professional Services, Inc.

Printed 6/8/2017

HydroCAD® 10.00-19 s/n 03363 © 2016 HydroCAD Software Solutions LLC

Page 29

**Summary for Pond 2AP: Diversion Structure 2**

Inflow Area = 1.870 ac, 54.01% Impervious, Inflow Depth = 12.43" for 100 yr back to back event  
 Inflow = 14.75 cfs @ 36.22 hrs, Volume= 1.937 af  
 Outflow = 14.75 cfs @ 36.23 hrs, Volume= 1.937 af, Atten= 0%, Lag= 0.6 min  
 Primary = 2.96 cfs @ 12.09 hrs, Volume= 0.271 af  
 Secondary = 12.08 cfs @ 36.24 hrs, Volume= 1.667 af

Routing by Sim-Route method, Time Span= 0.00-72.00 hrs, dt= 0.01 hrs  
 Peak Elev= 848.13' @ 36.35 hrs

Device	Routing	Invert	Outlet Devices
#1	Primary	844.50'	<b>12.0" Round Culvert</b> L= 4.0' Ke= 0.500 Inlet / Outlet Invert= 844.50' / 844.48' S= 0.0050 ' /' Cc= 0.900 n= 0.012 Concrete pipe, finished, Flow Area= 0.79 sf
#2	Secondary	845.10'	<b>24.0" Round Culvert</b> L= 273.0' Ke= 0.500 Inlet / Outlet Invert= 845.10' / 843.60' S= 0.0055 ' /' Cc= 0.900 n= 0.005, Flow Area= 3.14 sf

**Primary OutFlow** Max=2.82 cfs @ 12.09 hrs HW=845.86' TW=845.31' (Dynamic Tailwater)  
 ↑**1=Culvert** (Inlet Controls 2.82 cfs @ 3.59 fps)

**Secondary OutFlow** Max=11.52 cfs @ 36.24 hrs HW=847.84' TW=847.26' (Dynamic Tailwater)  
 ↑**2=Culvert** (Inlet Controls 11.52 cfs @ 3.67 fps)

**Summary for Pond 2P: MC-4500 Chamber infiltration**

Inflow Area = 1.870 ac, 54.01% Impervious, Inflow Depth = 1.74" for 100 yr back to back event  
 Inflow = 2.96 cfs @ 12.09 hrs, Volume= 0.271 af  
 Outflow = 0.02 cfs @ 8.46 hrs, Volume= 0.125 af, Atten= 99%, Lag= 0.0 min  
 Discarded = 0.02 cfs @ 8.46 hrs, Volume= 0.125 af

Routing by Sim-Route method, Time Span= 0.00-72.00 hrs, dt= 0.01 hrs  
 Peak Elev= 848.15' @ 36.35 hrs Surf.Area= 0.052 ac Storage= 0.215 af

Plug-Flow detention time= 1,723.9 min calculated for 0.125 af (46% of inflow)  
 Center-of-Mass det. time= 1,315.0 min ( 2,397.3 - 1,082.3 )

Volume	Invert	Avail.Storage	Storage Description
#1A	841.75'	0.112 af	<b>28.50"W x 79.57"L x 8.00"H Field A</b> 0.416 af Overall - 0.137 af Embedded = 0.280 af x 40.0% Voids
#2A	842.75'	0.137 af	<b>ADS_StormTech MC-4500 +Cap</b> x 54 Inside #1 Effective Size= 90.4"W x 60.0"H => 26.46 sf x 4.03'L = 106.5 cf Overall Size= 100.0"W x 60.0"H x 4.33'L with 0.31' Overlap 3 Rows of 18 Chambers Cap Storage= +35.7 cf x 2 x 3 rows = 214.2 cf
		0.249 af	Total Available Storage

Storage Group A created with Chamber Wizard

**17-06-05-Friendship village design**

MSE 24-hr 3 100 yr back to back Rainfall=7.46" x 2

Prepared by Westwood Professional Services, Inc.

Printed 6/8/2017

HydroCAD® 10.00-19 s/n 03363 © 2016 HydroCAD Software Solutions LLC

Page 30

Device	Routing	Invert	Outlet Devices
#1	Discarded	841.75'	<b>0.450 in/hr Exfiltration over Surface area</b> Phase-In= 0.05'

**Discarded OutFlow** Max=0.02 cfs @ 8.46 hrs HW=841.80' (Free Discharge)

↑**1=Exfiltration** (Exfiltration Controls 0.02 cfs)

**Summary for Pond 3AP: Diversion Structure-3**

Inflow Area = 2.280 ac, 89.91% Impervious, Inflow Depth = 14.18" for 100 yr back to back event  
 Inflow = 18.53 cfs @ 36.22 hrs, Volume= 2.694 af  
 Outflow = 18.53 cfs @ 36.23 hrs, Volume= 2.694 af, Atten= 0%, Lag= 0.6 min  
 Primary = 0.95 cfs @ 12.23 hrs, Volume= 0.285 af  
 Secondary = 17.75 cfs @ 36.23 hrs, Volume= 2.409 af

Routing by Sim-Route method, Time Span= 0.00-72.00 hrs, dt= 0.01 hrs  
 Peak Elev= 855.04' @ 36.23 hrs

Device	Routing	Invert	Outlet Devices
#1	Primary	852.00'	<b>5.0" Round Culvert</b> L= 9.0' Ke= 0.500 Inlet / Outlet Invert= 852.00' / 851.95' S= 0.0056 ' Cc= 0.900 n= 0.012 Concrete pipe, finished, Flow Area= 0.14 sf
#2	Secondary	852.50'	<b>24.0" Round Culvert</b> L= 25.0' RCP, sq.cut end projecting, Ke= 0.500 Inlet / Outlet Invert= 852.50' / 852.25' S= 0.0100 ' Cc= 0.900 n= 0.012 Concrete pipe, finished, Flow Area= 3.14 sf

**Primary OutFlow** Max=0.94 cfs @ 12.23 hrs HW=854.94' TW=852.88' (Dynamic Tailwater)

↑**1=Culvert** (Inlet Controls 0.94 cfs @ 6.91 fps)

**Secondary OutFlow** Max=17.73 cfs @ 36.23 hrs HW=855.03' TW=847.20' (Dynamic Tailwater)

↑**2=Culvert** (Barrel Controls 17.73 cfs @ 5.75 fps)

**Summary for Pond 3P: SC-740 Chamber infiltration**

Inflow Area = 2.280 ac, 89.91% Impervious, Inflow Depth = 1.50" for 100 yr back to back event  
 Inflow = 0.95 cfs @ 12.23 hrs, Volume= 0.285 af  
 Outflow = 0.04 cfs @ 4.81 hrs, Volume= 0.199 af, Atten= 96%, Lag= 0.0 min  
 Discarded = 0.04 cfs @ 4.81 hrs, Volume= 0.199 af

Routing by Sim-Route method, Time Span= 0.00-72.00 hrs, dt= 0.01 hrs  
 Peak Elev= 853.93' @ 36.46 hrs Surf.Area= 0.078 ac Storage= 0.191 af

Plug-Flow detention time= 1,688.9 min calculated for 0.199 af (70% of inflow)

Center-of-Mass det. time= 1,280.1 min ( 2,287.0 - 1,006.9 )

Volume	Invert	Avail.Storage	Storage Description
#1A	849.70'	0.102 af	<b>20.50'W x 166.20'L x 4.50'H Field A</b> 0.352 af Overall - 0.097 af Embedded = 0.255 af x 40.0% Voids
#2A	850.70'	0.097 af	<b>ADS StormTech SC-740</b> x 92 Inside #1 Effective Size= 44.6"W x 30.0"H => 6.45 sf x 7.12'L = 45.9 cf Overall Size= 51.0"W x 30.0"H x 7.56'L with 0.44' Overlap Row Length Adjustment= +0.44' x 6.45 sf x 4 rows

**17-06-05-Friendship village design**

MSE 24-hr 3 100 yr back to back Rainfall=7.46" x 2

Prepared by Westwood Professional Services, Inc.

Printed 6/8/2017

HydroCAD® 10.00-19 s/n 03363 © 2016 HydroCAD Software Solutions LLC

Page 31

0.199 af Total Available Storage

Storage Group A created with Chamber Wizard

Device	Routing	Invert	Outlet Devices
#1	Discarded	849.70'	<b>0.450 in/hr Exfiltration over Surface area</b> Phase-In= 0.05'

**Discarded OutFlow** Max=0.04 cfs @ 4.81 hrs HW=849.75' (Free Discharge)↑**1=Exfiltration** (Exfiltration Controls 0.04 cfs)**Summary for Pond 4AP: Diversion Structure 4**

Inflow Area = 2.060 ac, 37.86% Impervious, Inflow Depth = 11.55" for 100 yr back to back event  
 Inflow = 18.57 cfs @ 36.17 hrs, Volume= 1.983 af  
 Outflow = 18.57 cfs @ 36.18 hrs, Volume= 1.983 af, Atten= 0%, Lag= 0.6 min  
 Primary = 0.08 cfs @ 36.18 hrs, Volume= 0.158 af  
 Secondary = 18.49 cfs @ 36.18 hrs, Volume= 1.825 af

Routing by Sim-Route method, Time Span= 0.00-72.00 hrs, dt= 0.01 hrs

Peak Elev= 848.74' @ 36.18 hrs

Device	Routing	Invert	Outlet Devices
#1	Primary	845.25'	<b>2.0" Round Culvert</b> L= 50.0' Ke= 0.500 Inlet / Outlet Invert= 845.25' / 845.00' S= 0.0050 ' Cc= 0.900 n= 0.012 Concrete pipe, finished, Flow Area= 0.02 sf
#2	Secondary	846.25'	<b>24.0" Round Culvert</b> L= 50.0' Ke= 0.500 Inlet / Outlet Invert= 846.25' / 843.75' S= 0.0500 ' Cc= 0.900 n= 0.012 Concrete pipe, finished, Flow Area= 3.14 sf

**Primary OutFlow** Max=0.08 cfs @ 36.18 hrs HW=848.74' TW=845.31' (Dynamic Tailwater)↑**1=Culvert** (Outlet Controls 0.08 cfs @ 3.71 fps)**Secondary OutFlow** Max=18.48 cfs @ 36.18 hrs HW=848.74' TW=846.87' (Dynamic Tailwater)↑**2=Culvert** (Inlet Controls 18.48 cfs @ 5.88 fps)**Summary for Pond 4P: SC-740 Chamber filtration**

Inflow Area = 2.060 ac, 37.86% Impervious, Inflow Depth = 0.92" for 100 yr back to back event  
 Inflow = 0.08 cfs @ 36.18 hrs, Volume= 0.158 af  
 Outflow = 0.05 cfs @ 10.68 hrs, Volume= 0.158 af, Atten= 41%, Lag= 0.0 min  
 Discarded = 0.05 cfs @ 10.68 hrs, Volume= 0.158 af

Routing by Sim-Route method, Time Span= 0.00-72.00 hrs, dt= 0.01 hrs

Peak Elev= 845.56' @ 40.33 hrs Surf.Area= 0.029 ac Storage= 0.007 af

Plug-Flow detention time= 54.6 min calculated for 0.158 af (100% of inflow)

Center-of-Mass det. time= 54.6 min ( 1,750.9 - 1,696.3 )

**17-06-05-Friendship village design**

MSE 24-hr 3 100 yr back to back Rainfall=7.46" x 2

Prepared by Westwood Professional Services, Inc.

Printed 6/8/2017

HydroCAD® 10.00-19 s/n 03363 © 2016 HydroCAD Software Solutions LLC

Page 32

Volume	Invert	Avail.Storage	Storage Description
#1A	845.00'	0.033 af	<b>15.75'W x 80.76'L x 4.00'H Field A</b> 0.117 af Overall - 0.035 af Embedded = 0.082 af x 40.0% Voids
#2A	846.00'	0.035 af	<b>ADS_StormTech SC-740</b> x 33 Inside #1 Effective Size= 44.6"W x 30.0"H => 6.45 sf x 7.12'L = 45.9 cf Overall Size= 51.0"W x 30.0"H x 7.56'L with 0.44' Overlap Row Length Adjustment= +0.44' x 6.45 sf x 3 rows
		0.068 af	Total Available Storage

Storage Group A created with Chamber Wizard

Device	Routing	Invert	Outlet Devices
#1	Discarded	845.00'	<b>1.630 in/hr Exfiltration over Surface area</b> Phase-In= 0.05'

**Discarded OutFlow** Max=0.05 cfs @ 10.68 hrs HW=845.05' (Free Discharge)

↑**1=Exfiltration** (Exfiltration Controls 0.05 cfs)

**Summary for Pond 22P: Proposed Pond - Revised Existing Pond**

Inflow Area = 8.420 ac, 52.38% Impervious, Inflow Depth = 20.77" for 100 yr back to back event  
 Inflow = 116.13 cfs @ 36.19 hrs, Volume= 14.571 af  
 Outflow = 27.51 cfs @ 36.58 hrs, Volume= 14.386 af, Atten= 76%, Lag= 23.4 min  
 Primary = 27.51 cfs @ 36.58 hrs, Volume= 14.386 af

Routing by Sim-Route method, Time Span= 0.00-72.00 hrs, dt= 0.01 hrs  
 Starting Elev= 843.60' Surf.Area= 0.958 ac Storage= 2.959 af  
 Peak Elev= 847.91' @ 36.58 hrs Surf.Area= 1.427 ac Storage= 8.256 af (5.297 af above start)

Plug-Flow detention time= 953.8 min calculated for 11.427 af (78% of inflow)

Center-of-Mass det. time= 467.9 min ( 2,071.5 - 1,603.7 )

Volume	Invert	Avail.Storage	Storage Description
#1	837.70'	13.109 af	<b>Custom Stage Data (Prismatic)</b> Listed below (Recalc)

Elevation (feet)	Surf.Area (acres)	Inc.Store (acre-feet)	Cum.Store (acre-feet)
837.70	0.045	0.000	0.000
844.00	1.020	3.355	3.355
845.00	1.176	1.098	4.453
846.00	1.275	1.225	5.678
848.00	1.434	2.709	8.387
850.00	1.613	3.047	11.434
851.00	1.737	1.675	13.109

Device	Routing	Invert	Outlet Devices
#1	Primary	843.60'	<b>24.0" Round Culvert</b> L= 101.0' RCP, end-section conforming to fill, Ke= 0.500 Inlet / Outlet Invert= 843.60' / 841.15' S= 0.0243 ' / Cc= 0.900 n= 0.013 Concrete pipe, straight & clean, Flow Area= 3.14 sf
#2	Device 1	843.60'	<b>9.0" Vert. Orifice/Grate</b> C= 0.600
#3	Device 1	846.80'	<b>48.0" Horiz. Orifice/Grate</b> C= 0.600 Limited to weir flow at low heads

**17-06-05-Friendship village design**

MSE 24-hr 3 100 yr back to back Rainfall=7.46" x 2

Prepared by Westwood Professional Services, Inc.

Printed 6/8/2017

HydroCAD® 10.00-19 s/n 03363 © 2016 HydroCAD Software Solutions LLC

Page 33

**Primary OutFlow** Max=27.51 cfs @ 36.58 hrs HW=847.91' TW=0.00' (Dynamic Tailwater)

↑ **1=Culvert** (Inlet Controls 27.51 cfs @ 8.76 fps)

↑ **2=Orifice/Grate** (Passes < 4.22 cfs potential flow)

↑ **3=Orifice/Grate** (Passes < 47.94 cfs potential flow)

## APPENDIX C

WATER QUALITY  
BASIN VOLUMES  
STORMTECH DESIGN PARAMETERS  
PRE-DEVELOPMENT DRAINAGE MAP  
POST-DEVELOPMENT DRAINAGE MAP

CASE PL2017-72

Friendship Village Basin Calcs

Job Number: 9018.00  
Date: 6/5/2017

Detention Area	Infiltration Rate (in/hr)	Impervious Area (SF)	Req. WQV (CF)	Req. Depth (FT)	Req. Surface Area (SF)	Provided Area (SF)	Provided WQV (CF)
1	0.45	43996	3666.3	1.8	2037	2831	5096
2	0.45	43996	3666.3	1.8	2037	2268	4082
3	0.45	89298	7441.5	1.8	4134	4162	7492
4	1.63	33977	2831.4	2.25	1258	1272	2862

CASE PL2017-72

P8 Urban Catchment Model, Version 3.5

Case	0009018_Friendship_Proposed_170605.p8c	FirstDate	10/01/58	Run Date	06/06/17
Title	0009018_friendship_Proposed_170605	LastDate	09/30/59	Precip(in)	25.3
PrecFile	misp_4989.pcp	Events	66	Rain(in)	23.76
PartFile	nurp50.p8p	TotalHrs	8545	Snow(in)	1.55
				TotalYrs	0.97

Mass Balances by Device

Device: OVERALL	Type:	NONE																							
	Flow	Loads(lbs)											Concentrations (ppm)												
Mass Balance Term	acre-ft	P0%	P10%	P30%	P50%	P80%	TSS	TP	TKN	CU	PB	ZN	HC	P0%	P10%	P30%	P50%	P80%	TSS	TP	TKN	CU	PB	ZN	HC
01 watershed inflows	17.31	47.04	1125.81	1125.81	1125.81	2251.61	5629.04	17.66	78.89	2.55	1.11	8.41	138.41	1.00	23.93	23.93	23.93	47.86	119.66	0.38	1.68	0.05	0.02	0.18	2.94
03 infiltrate	7.72	20.99	280.77	56.48	12.44	2.54	352.23	3.42	17.84	0.41	0.11	1.90	13.17	1.00	13.38	2.69	0.59	0.12	16.78	0.16	0.85	0.02	0.01	0.09	0.63
04 exfiltrate	7.72	2.10	0.00	0.00	0.00	0.00	0.00	0.21	1.26	0.03	0.00	0.13	0.52	0.10						0.01	0.06	0.00	0.00	0.01	0.02
05 filtered	0.00	20.98	326.79	73.93	17.11	3.55	421.38	3.69	18.86	0.43	0.12	2.01	14.73	0.00	0.00	0.00	0.00	0.00	0.00	0.00	0.00	0.00	0.00	0.00	0.00
06 normal outlet	9.59	23.71	32.53	12.80	8.28	5.02	58.63	2.55	15.03	0.34	0.06	1.60	7.25	0.91	1.25	0.49	0.32	0.19	2.25	0.10	0.58	0.01	0.00	0.06	0.28
08 sedimen + decay	0.00	0.00	740.34	1038.55	1100.41	2243.04	5122.34	11.09	43.19	1.74	0.92	4.61	115.25						0.00	0.00	0.00	0.00	0.00	0.00	0.00
09 total inflow	17.31	47.04	1125.81	1125.81	1125.81	2251.61	5629.04	17.66	78.89	2.55	1.11	8.41	138.41	1.00	23.93	23.93	23.93	47.86	119.66	0.38	1.68	0.05	0.02	0.18	2.94
10 surface outflow	9.59	23.71	32.53	12.80	8.28	5.02	58.63	2.55	15.03	0.34	0.06	1.60	7.25	0.91	1.25	0.49	0.32	0.19	2.25	0.10	0.58	0.01	0.00	0.06	0.28
11 groundw outflow	7.72	2.10	0.00	0.00	0.00	0.00	0.00	0.21	1.26	0.03	0.00	0.13	0.52	0.10						0.01	0.06	0.00	0.00	0.01	0.02
12 total outflow	17.31	25.81	32.53	12.80	8.28	5.02	58.63	2.76	16.29	0.37	0.06	1.74	7.77	0.55	0.69	0.27	0.18	0.11	1.25	0.06	0.35	0.01	0.00	0.04	0.17
13 total trapped	0.00	20.98	1067.13	1112.48	1117.52	2246.60	5543.73	14.77	62.05	2.17	1.04	6.62	129.98												
14 storage increase	0.00	0.25	25.11	0.48	0.00	0.00	25.60	0.12	0.53	0.01	0.01	0.06	0.64												
15 mass balance check	0.00	0.00	1.03	0.04	0.01	0.00	1.08	0.00	0.02	0.00	0.00	0.00	0.02												
Load Reduction (%)	0.00	44.61	94.79	98.82	99.26	99.78	98.48	83.64	78.65	84.99	93.91	78.65	93.91												

Device: 2P	Type:	POND																							
	Flow	Loads(lbs)											Concentrations (ppm)												
Mass Balance Term	acre-ft	P0%	P10%	P30%	P50%	P80%	TSS	TP	TKN	CU	PB	ZN	HC	P0%	P10%	P30%	P50%	P80%	TSS	TP	TKN	CU	PB	ZN	HC
01 watershed inflows	2.00	5.44	130.23	130.23	130.23	260.45	651.13	2.04	9.13	0.30	0.13	0.97	16.01	1.00	23.93	23.93	23.93	47.86	119.65	0.38	1.68	0.05	0.02	0.18	2.94
03 infiltrate	2.00	5.44	71.87	14.36	3.15	0.64	90.02	0.88	4.61	0.10	0.03	0.49	3.39	1.00	13.21	2.64	0.58	0.12	16.54	0.16	0.85	0.02	0.00	0.09	0.62
04 exfiltrate	2.00	0.54	0.00	0.00	0.00	0.00	0.00	0.05	0.33	0.01	0.00	0.03	0.14	0.10						0.01	0.06	0.00	0.00	0.01	0.02
05 filtered	0.00	4.90	71.87	14.36	3.15	0.64	90.02	0.83	4.28	0.10	0.03	0.46	3.25	0.00	0.00	0.00	0.00	0.00	0.00	0.00	0.00	0.00	0.00	0.00	0.00
08 sedimen + decay	0.00	0.00	58.19	115.87	127.08	259.81	560.94	1.16	4.52	0.19	0.10	0.48	12.62						0.00	0.00	0.00	0.00	0.00	0.00	0.00
09 total inflow	2.00	5.44	130.23	130.23	130.23	260.45	651.13	2.04	9.13	0.30	0.13	0.97	16.01	1.00	23.93	23.93	23.93	47.86	119.65	0.38	1.68	0.05	0.02	0.18	2.94
11 groundw outflow	2.00	0.54	0.00	0.00	0.00	0.00	0.00	0.05	0.33	0.01	0.00	0.03	0.14	0.10						0.01	0.06	0.00	0.00	0.01	0.02
12 total outflow	2.00	0.54	0.00	0.00	0.00	0.00	0.00	0.05	0.33	0.01	0.00	0.03	0.14	0.10						0.01	0.06	0.00	0.00	0.01	0.02
13 total trapped	0.00	4.90	130.05	130.22	130.23	260.45	650.96	1.99	8.80	0.29	0.13	0.94	15.87												
14 storage increase	0.00	0.00	0.00	0.00	0.00	0.00	0.00	0.00	0.00	0.00	0.00	0.00	0.00												
15 mass balance check	0.00	0.00	0.17	0.00	0.00	0.00	0.18	0.00	0.00	0.00	0.00	0.00	0.00												
Load Reduction (%)	0.00	90.00	99.87	100.00	100.00	100.00	99.97	97.33	96.39	97.47	99.13	96.39	99.13												

Device: 3P	Type:	POND																							
	Flow	Loads(lbs)											Concentrations (ppm)												
Mass Balance Term	acre-ft	P0%	P10%	P30%	P50%	P80%	TSS	TP	TKN	CU	PB	ZN	HC	P0%	P10%	P30%	P50%	P80%	TSS	TP	TKN	CU	PB	ZN	HC
01 watershed inflows	3.81	10.34	247.78	247.78	247.78	495.56	1238.89	3.89	17.36	0.56	0.24	1.85	30.46	1.00	23.96	23.96	23.96	47.91	119.78	0.38	1.68	0.05	0.02	0.18	2.94
03 infiltrate	3.64	9.89	134.06	27.18	6.01	1.23	168.47	1.62	8.44	0.19	0.05	0.90	6.26	1.00	13.56	2.75	0.61	0.12	17.04	0.16	0.85	0.02	0.01	0.09	0.63
04 exfiltrate	3.64	0.99	0.00	0.00	0.00	0.00	0.00	0.10	0.59	0.01	0.00	0.06	0.25	0.10						0.01	0.06	0.00	0.00	0.01	0.02
05 filtered	0.00	8.90	134.06	27.18	6.01	1.23	168.47	1.52	7.85	0.18	0.05	0.84	6.02	0.00	0.00	0.00	0.00	0.00	0.00	0.00	0.00	0.00	0.00	0.00	0.00
07 spillway outlet	0.17	0.45	5.42	1.99	0.27	0.08	7.77	0.07	0.39	0.01	0.00	0.04	0.29	1.00	11.93	4.38	0.60	0.18	17.09	0.16	0.85	0.02	0.01	0.09	0.63
08 sedimen + decay	0.00	0.00	108.09	218.61	241.50	494.25	1062.45	2.19	8.52	0.36	0.19	0.91	23.91						0.00	0.00	0.00	0.00	0.00	0.00	0.00
09 total inflow	3.81	10.34	247.78	247.78	247.78	495.56	1238.89	3.89	17.36	0.56	0.24	1.85	30.46	1.00	23.96	23.96	23.96	47.91	119.78	0.38	1.68	0.05	0.02	0.18	2.94
10 surface outflow	0.17	0.45	5.42	1.99	0.27	0.08	7.77	0.07	0.39	0.01	0.00	0.04	0.29	1.00	11.93	4.38	0.60	0.18	17.09	0.16	0.85	0.02	0.01	0.09	0.63
11 groundw outflow	3.64	0.99	0.00	0.00	0.00	0.00	0.00	0.10	0.59	0.01	0.00	0.06	0.25	0.10						0.01	0.06	0.00	0.00	0.01	0.02
12 total outflow	3.81	1.44	5.42	1.99	0.27	0.08	7.77	0.17	0.98	0.02	0.00	0.10	0.54	0.14	0.52	0.19	0.03	0.01	0.75	0.02	0.09	0.00	0.00	0.01	0.05
13 total trapped	0.00	8.90	242.15	245.79	247.50	495.48	1230.91	3.71	16.37	0.54	0.24	1.75	29.92												
14 storage increase	0.00	0.00	0.00	0.00	0.00	0.00	0.00	0.00	0.00	0.00	0.00	0.00	0.00												
15 mass balance check	0.00	0.00	0.21	0.00	0.00	0.00	0.21	0.00	0.00	0.00	0.00	0.00	0.00												
Load Reduction (%)	0.00	86.04	97.73	99.20	99.89	99.98	99.36	95.54	94.33	96.02	98.23	94.33	98.23												

Device: 4P	Type:	POND																							
	Flow	Loads(lbs)											Concentrations (ppm)												
Mass Balance Term	acre-ft	P0%	P10%	P30%	P50%	P80%	TSS	TP	TKN	CU	PB	ZN	HC	P0%	P10%	P30%	P50%	P80%	TSS	TP	TKN	CU	PB	ZN	HC
01 watershed inflows	0.94	2.56	61.01	61.01	61.01	122.02	305.05	0.96	4.28	0.14	0.06	0.46	7.50	1.00	23.87	23.87	23.87	47.75	119.37	0.37	1.67	0.05	0.02	0.18	2.94
03 infiltrate	0.86	2.33	46.03	17.45	4.67	1.01	69.16	0.49	2.42	0.06	0.02	0.26	2.14	1.00	19.78	7.50	2.01	0.43	29						



**CASE PL2017-72**

P8 Urban Catchment Model, Version 3.5				Run Date	06/06/17
Case	0009018_Friendship_Proposed_170606.p8c	FirstDate	10/01/58	Precip(in)	25.3
Title	0009018_friendship_Proposed_170606	LastDate	09/30/59	Rain(in)	23.76
PrecFile	mzp_4989.pcp	Events	66	Snow(in)	1.55
PartFile	nurp50.p8p	TotalHrs	8545	TotalYrs	0.97

Devices Listed in Downstream Order

Device:	2P	Type:	POND
	Discharges normal outlet to		22P Proposed Pond
	Discharges spillway to		22P Proposed Pond
	Runoff from watershed		2S
Device:	3P	Type:	POND
	Discharges normal outlet to		22P Proposed Pond
	Discharges spillway to		22P Proposed Pond
	Runoff from watershed		3S
Device:	4P	Type:	POND
	Discharges infiltration to		22P Proposed Pond
	Discharges normal outlet to		22P Proposed Pond
	Discharges spillway to		22P Proposed Pond
	Runoff from watershed		4S
Device:	22P Proposed Pond	Type:	POND
	Discharges normal outlet to		out
	Discharges spillway to		out
	Runoff from watershed		5S
	Runoff from watershed		6S
Device:	Infiltration Pond	Type:	POND
	Discharges normal outlet to		out
	Discharges spillway to		out
	Runoff from watershed		1S
Device:	out	Type:	PIPE

CASE PL2017-72

P8-V3.X 0009018\_Friendship\_Proposed\_170606.p8c

Watershed Label							Directly Connected UnSwept Areas-->				Directly Connected Swept Areas-->				Street Sweeping Parameters			
	Total	Outflow	Percol	Pervious	Indirect	Pervious	Imperv	Depress	Runoff	Imperv	Depress	Runoff	Imperv	Start	Stop	Sweep	Sweep	
	Area	Device	Device	Curve	Imperv	Load	Fraction	Storage	Coef	Load	Fraction	Storage	Coef	Date	Date	Effic	Freq	
	acres			Number	Fraction	Factor	Fraction	inches		Factor	Fraction	inches		MMDD	MMDD		1/week	
1S	1.63	Infiltration Pond		61	0.000	1	0.6376	0.02	1	1	0	0.02	1	1	101	1231	1	0
2S	1.889	2P		61	0.000	1	0.5289	0.02	1	1	0	0.02	1	1	101	1231	1	0
3S	2.078	3P		61	0.000	1	0.9148	0.02	1	1	0	0.02	1	1	101	1231	1	0
4S	1.731	4P		61	0.000	1	0.2704	0.02	1	1	0	0.02	1	1	101	1231	1	0
5S	4.44	22P Proposed Pond		61	0.000	1	0.4414	0.02	1	1	0	0.02	1	1	101	1231	1	0
6S	4.076	22P Proposed Pond		61	0.000	1	0.5569	0.02	1	1	0	0.02	1	1	101	1231	1	0





# CASE PL2017-72

P8 Urban Catchment Model, Version 3.5				Run Date	06/06/17
Case	0009018_Friendship_Proposed_170606.p8c	FirstDate	10/01/58	Precip(in)	25.3
Title	0009018_friendship_Proposed_170606	LastDate	09/30/59	Rain(in)	23.76
PrecFile	msp_4989.pcp	Events	66	Snow(in)	1.55
PartFile	nurp50.p8p	TotalHrs	8545	TotalYrs	0.97

File Directory	N:\0009018.00\docs\Design\Storm\p8\
Case Title	0009018_friendship_Proposed_170606
Case File	0009018_Friendship_Proposed_170606.p8c
Particle File	nurp50.p8p
Temperature File	msp_4889.tem
Storm File	msp_4989.pcp
Precip Scale Factor	1

Watersheds	6
Devices	6
Particles	5
WQ Components	7

Start Date	09/03/58
Keep Date	10/01/58
Stop Date	09/30/59
Storm Count	66
Total Hours	8545
Wet Hours	686
Precip (in)	25
Rain (in)	24
Snowfall (in)	2
Snowmelt (in)	2
EvapoTran(in)	23

Overall TSS Removal(%)	1
Water Balance Error(%)	0
TSS Mass Balance Error (%)	0

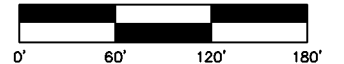
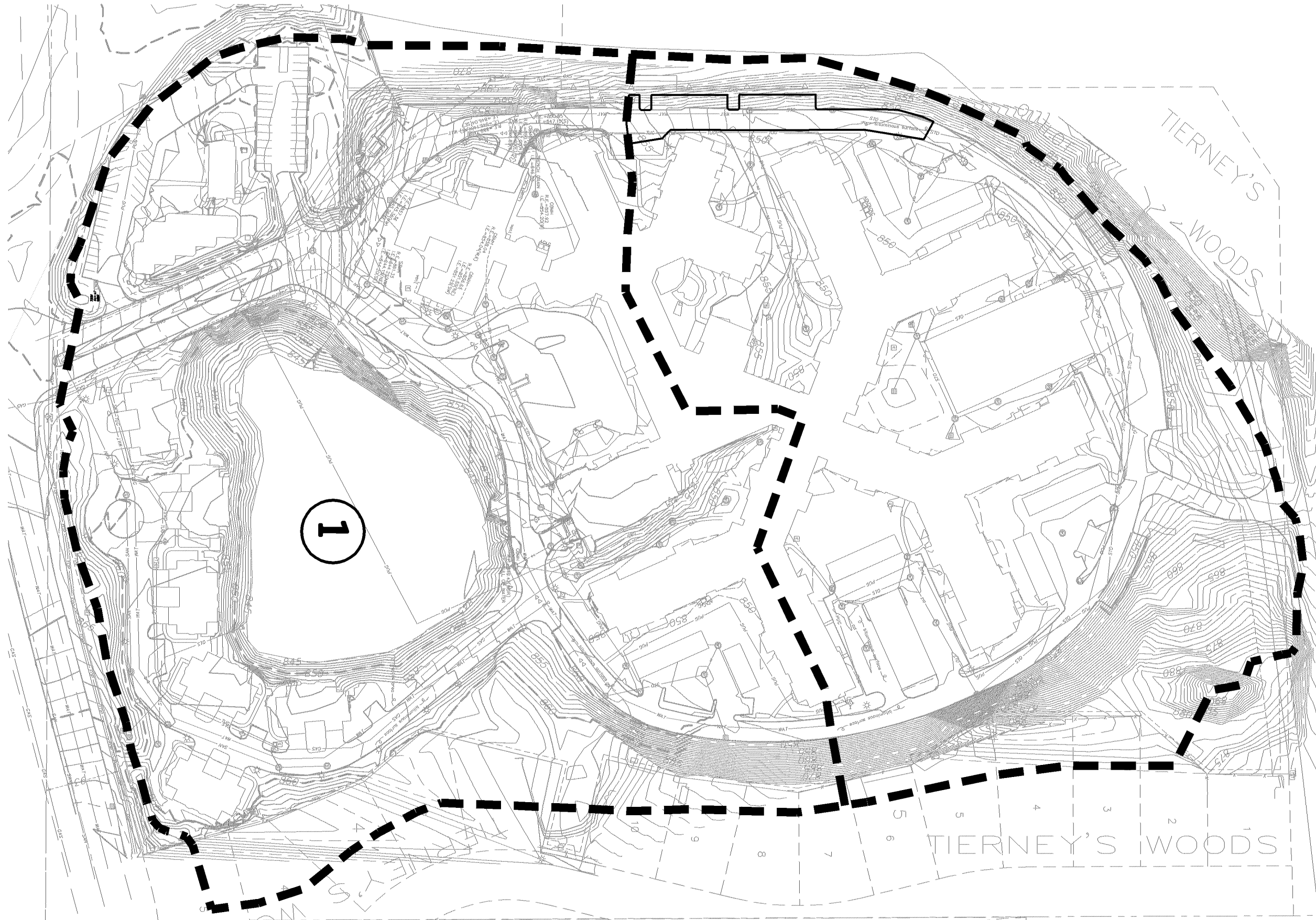

NOT FOR CONSTRUCTION

0009018DAE01.dwg

Date: 12/06/2016 Sheet: 1 OF 2

### Westwood

Phone (370) 253-9495 3701 12th Street North, Suite 206  
Fax (370) 253-8737 St. Cloud, MN 56303  
Toll Free (800) 270-9495 westwoodps.com  
Westwood Professional Services, Inc.

I hereby certify that this plan was prepared by me or under my direct supervision and that I am a duly licensed PROFESSIONAL ENGINEER under the laws of the State of Minnesota.

Date: 12/06/2016 License No. \_\_\_\_\_

Revisions:

Designed: \_\_\_\_\_

Checked: \_\_\_\_\_

Drawn: \_\_\_\_\_

Record Drawing by/date: \_\_\_\_\_

Prepared for:

**FRIENDSHIP VILLAGE**

Bloomington, MN

Existing Drainage Map

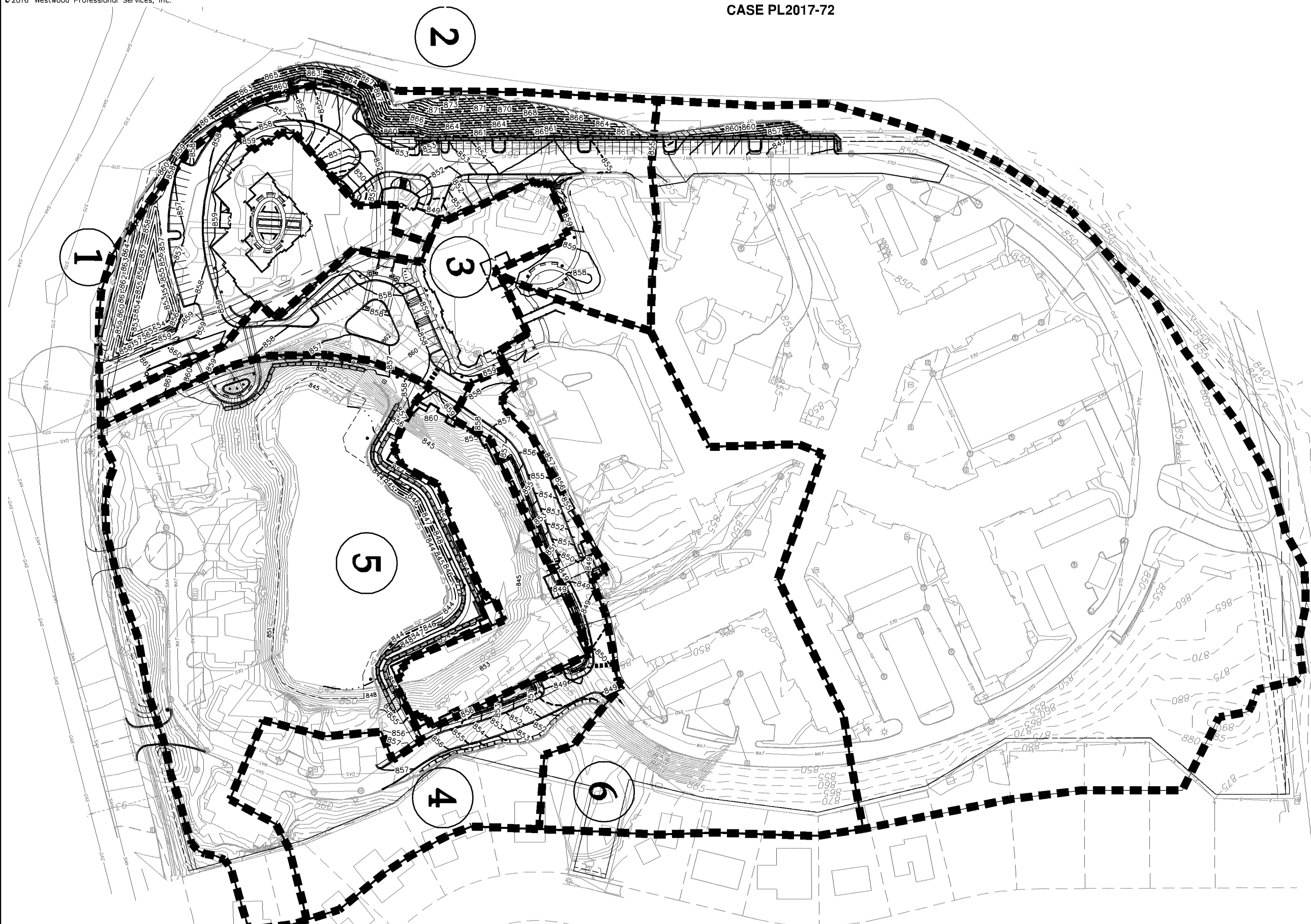

NOT FOR CONSTRUCTION

0009018DAF01.dwg

Date: 6/08/2017 Sheet: 2 OF 2

**FRIENDSHIP  
VILLAGE**  
Bloomington, MN

Proposed  
Drainage

**Westwood**

Phone (370) 253-9495 3701 12th Street North, Suite 208  
 Fax (370) 253-8737 St. Cloud, MN 56309  
 Toll Free (800) 270-9495 westwoodps.com

I hereby certify that this plan was prepared by me or under my direct supervision and that I am a duly licensed PROFESSIONAL ENGINEER under the laws of the State of Minnesota.

Date: \_\_\_\_\_ Licensed No. \_\_\_\_\_

Revisions:

Designed: \_\_\_\_\_  
 Checked: \_\_\_\_\_  
 Drawn: \_\_\_\_\_  
 Record Drawing by/date: \_\_\_\_\_

Prepared for:

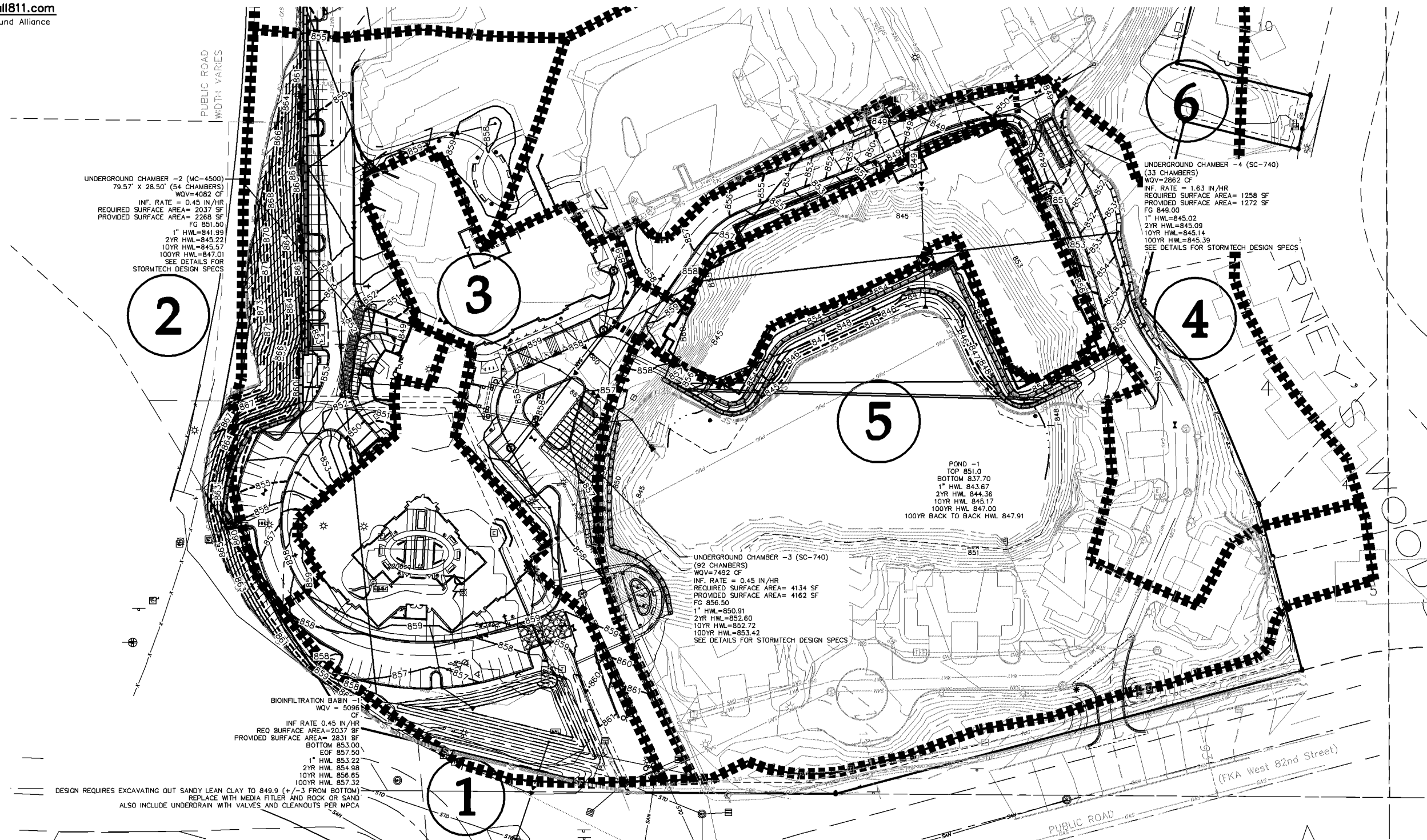

2

3

5

4

6

1

**Grading Legend**

EXISTING	PROPOSED	
		PROPERTY LINE
		INDEX CONTOUR
		INTERVAL CONTOUR
		CURB AND GUTTER
		DRAINAGE AREA

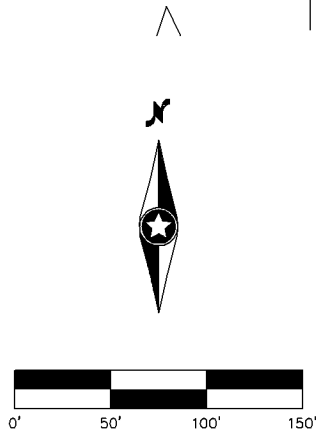

NOT FOR CONSTRUCTION

Designed: \_\_\_\_\_  
 Checked: \_\_\_\_\_  
 Drawn: \_\_\_\_\_  
 Record Drawing by/date: \_\_\_\_\_

Revisions:  
 \_\_\_\_\_  
 \_\_\_\_\_  
 \_\_\_\_\_  
 \_\_\_\_\_  
 \_\_\_\_\_

I hereby certify that this plan was prepared by me or under my direct supervision and that I am a duly Licensed PROFESSIONAL ENGINEER under the laws of the State of Minnesota.

Date: \_\_\_\_\_ License No. \_\_\_\_\_

Prepared for:

**Greystone Communities**

**Friendship Village**  
 Bloomington, MN

Drainage Area Map

Date: 6/7/2017  
 Sheet: 1 OF 1

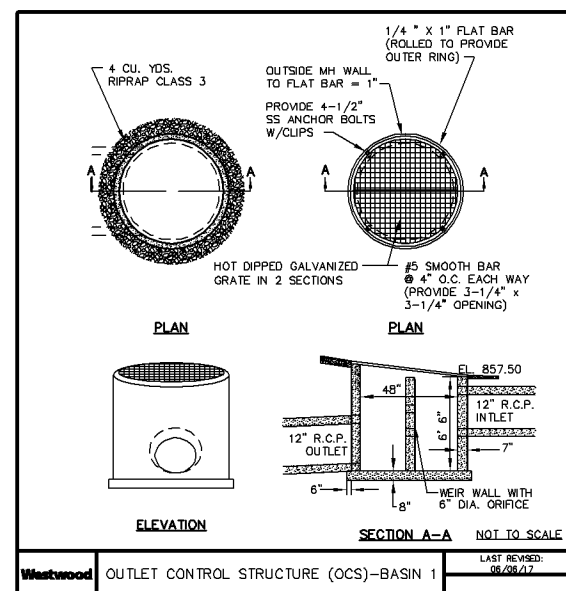
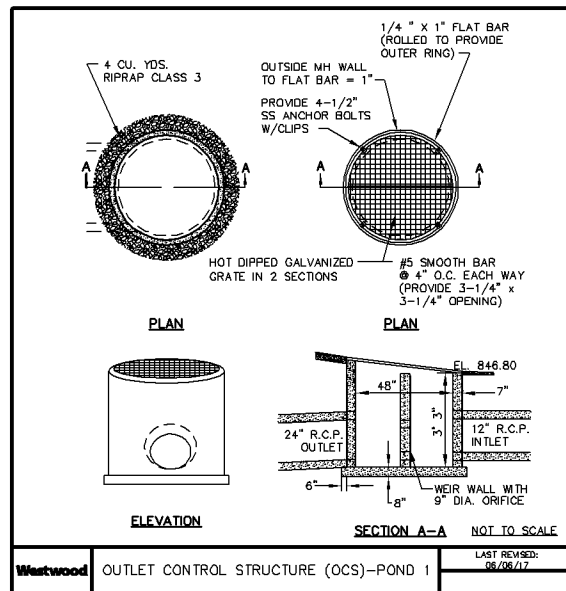
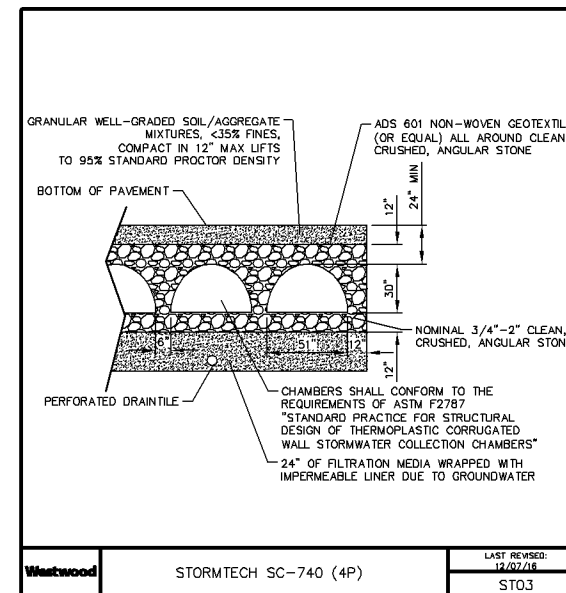
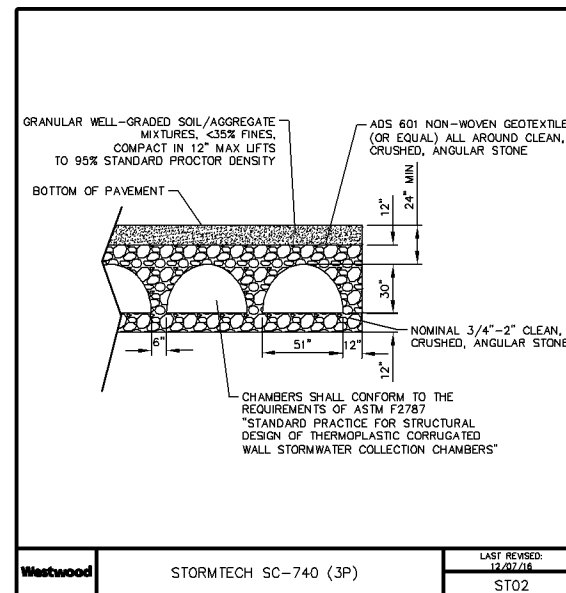
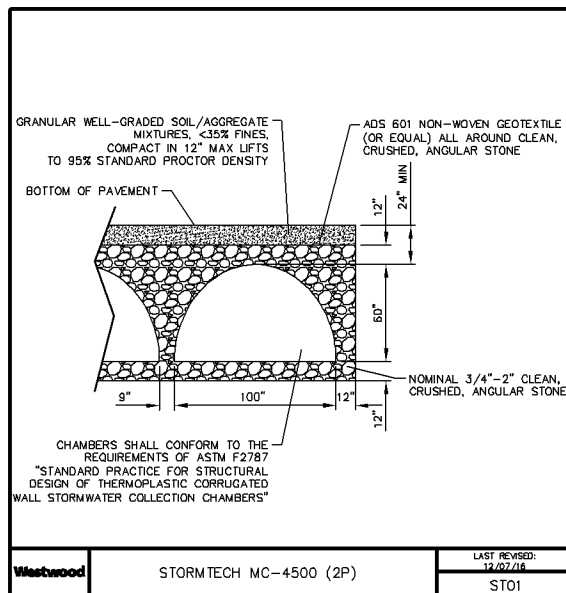

Designed: \_\_\_\_\_

Checked: \_\_\_\_\_

Drawn: \_\_\_\_\_

Record Drawing by/date: \_\_\_\_\_

Revisions: \_\_\_\_\_

\_\_\_\_\_

\_\_\_\_\_

\_\_\_\_\_

\_\_\_\_\_

\_\_\_\_\_

\_\_\_\_\_

\_\_\_\_\_

\_\_\_\_\_

I hereby certify that this plan was prepared by me or under my direct supervision and that I am a duly licensed PROFESSIONAL ENGINEER under the laws of the State of Minnesota.

Date: \_\_\_\_\_ License No. \_\_\_\_\_

Prepared for:

**Greystone Communities**

**Friendship Village**  
Bloomington, MN

Storm Details

Date: 6/7/2017

Sheet: 1 OF 1

APPENDIX D  
GEOTECHNICAL REPORT

**CASE PL2017-72**  
*Draft – Subject to Change*

## **Geotechnical Evaluation Report**

Friendship Village Redevelopment  
Highwood Drive and Townline Road  
Bloomington, Minnesota

*Prepared for*

## **Greystone Communities**

### **Professional Certification:**

I hereby certify that this plan, specification, or report was prepared by me or under my direct supervision and that I am a duly licensed Professional Engineer under the laws of the State of Minnesota.

Steven B. Martin, PE  
Senior Engineer  
License Number: 41271  
November 23, 2016

Project B1610072

Braun Intertec Corporation



CASE PL2017-72

Braun Intertec Corporation  
11001 Hampshire Avenue S  
Minneapolis, MN 55438

Phone: 952.995.2000  
Fax: 952.995.2020  
Web: braunintertec.com

***Draft – Subject to Change***

November 23, 2016

Project B1610072

Mr. Patrick Gleason  
Greystone Communities  
225 E. John Carpenter Freeway, Suite 700  
Irving, TX 75062

Re: Geotechnical Evaluation  
Friendship Village Redevelopment  
Parkview Lane and Circle Drive  
Bloomington, Minnesota

Dear Mr. Gleason:

We are pleased to present this Geotechnical Evaluation Report for the proposed Redevelopment at Friendship Village.

Thank you for making Braun Intertec your geotechnical consultant for this project. If you have questions about this report, or if there are other services that we can provide in support of our work to date please contact Steve Martin at 651.487.7026 ([smartin@braunintertec.com](mailto:smartin@braunintertec.com)) or Mark Jenkins at 651.487.7010 ([mjenkins@braunintertec.com](mailto:mjenkins@braunintertec.com)).

Sincerely,

BRAUN INTERTEC CORPORATION

Steven B. Martin, PE  
Senior Engineer

Mark L. Jenkins, PE  
Senior Engineer

c: Mr. Ryan Bluhm; Westwood Professional Services

## Table of Contents

Description	Page
A. Introduction.....	1
A.1. Project Description.....	1
A.2. Site Conditions and History.....	2
A.3. Purpose.....	3
A.4. Background Information and Reference Documents.....	3
A.5. Scope of Services.....	4
B. Results.....	5
B.1. Geologic Overview.....	5
B.2. Previous Geotechnical Information.....	5
B.3. Boring Results.....	6
B.4. Groundwater.....	7
B.5. Laboratory Test Results.....	7
C. Recommendations.....	8
C.1. Design and Construction Discussion.....	8
C.1.a. Building Subgrade Preparation.....	8
C.1.b. Groundwater.....	9
C.1.c. Reuse of On-Site Soils.....	9
C.1.d. Pavement.....	10
C.1.e. Temporary Retention.....	10
C.1.f. Stormwater.....	10
C.2. Site Grading and Subgrade Preparation.....	11
C.2.a. Building Subgrade Excavations.....	11
C.2.b. Excavation Oversizing.....	12
C.2.c. Excavated Slopes.....	13
C.2.d. Excavation Dewatering.....	14
C.2.e. Pavement and Exterior Slab Subgrade Preparation.....	14
C.2.f. Pavement Subgrade Proofroll.....	14
C.2.g. Fill Materials and Compaction.....	15
C.2.h. Special Inspections of Soils.....	16
C.3. Spread Footings.....	17
C.4. Construction Adjacent to Existing Structures.....	17
C.4.a. Excavations.....	17
C.4.b. Footing Depth.....	18
C.5. Below-Grade Walls.....	18
C.5.a. Drainage Control.....	18
C.5.b. Configuring and Resisting Lateral Loads.....	20
C.6. Interior Slabs.....	21
C.6.a. Subgrade Modulus.....	21
C.6.b. Moisture Vapor Protection.....	21
C.7. Frost Protection.....	21
C.7.a. General.....	21
C.7.b. Frost Heave Mitigation.....	22

## Table of Contents (continued)

Description	Page
C.8. Pavements and Exterior Slabs .....	23
C.8.a. Design Sections .....	23
C.8.b. Bituminous Pavement Materials .....	24
C.8.c. Concrete Pavements .....	24
C.8.d. Subgrade Drainage .....	24
C.8.e. Performance and Maintenance .....	24
C.9. Utilities .....	25
C.9.a. Subgrade Stabilization .....	25
C.9.b. Corrosion Potential .....	25
C.10. Stormwater .....	26
C.11. Equipment Support .....	26
D. Procedures .....	27
D.1. Penetration Test Borings .....	27
D.2. Exploration Logs .....	27
D.2.a. Log of Boring Sheets .....	27
D.2.b. Geologic Origins .....	28
D.3. Material Classification and Testing .....	28
D.3.a. Visual and Manual Classification .....	28
D.3.b. Laboratory Testing .....	28
D.4. Groundwater Measurements .....	28
E. Qualifications .....	28
E.1. Variations in Subsurface Conditions .....	28
E.1.a. Material Strata .....	28
E.1.b. Groundwater Levels .....	29
E.2. Continuity of Professional Responsibility .....	29
E.2.a. Plan Review .....	29
E.2.b. Construction Observations and Testing .....	29
E.3. Use of Report .....	30
E.4. Standard of Care .....	30

### Appendix

Soil Boring Location Sketch

Log of Boring Sheets ST-1 through ST-22

Descriptive Terminology of Soil

## A. Introduction

### A.1. Project Description

This Geotechnical Evaluation Report addresses the proposed design and construction of two new buildings at Friendship Village in Bloomington, Minnesota. Tables 1 and 2 provide project details.

**Table 1. Building Description**

Aspect	Description
Below grade levels	1 MS & AL Building 1 Residential Living
Above grade levels	3 MS & AL Building 4 Residential Living
Lowest level floor elevation	948.5 MC & AL Building 951.0 Residential Living
Column loads (kips)	Less than 350 (Assumed)
Wall loads (kips/ft)	Less than 6 (Assumed)
Nature of construction	Spread footings with masonry or poured concrete below grade walls, precast plank first floor slab, stick frame above.
Cuts or fills for buildings	10'-25' cuts to basement elevation MC & AL 0 to 7' cuts outside of pond Residential Living, 8' fills in existing pond (Provided)
Tolerable building settlement	1 inch (Assumed)
Comments	A portion of the existing wetland/pond will be filled in for a portion of the Residential Living building.

**Table 2. Pavement Details**

Aspect	Description
Pavement type(s)	Bituminous drives and above grade parking, concrete for below grade parking
Provided/Assumed Pavement loads	Parking: 50,000 ESALs*
	Drive Lanes: 150,000 ESALs*
Grade changes	Less than 5’ from existing grades(Provided)

\*Equivalent 18,000-lb single axle loads based on 20-year design.

The boring location sketch in the Appendix shows an overlay of the proposed new buildings on the existing site layout.

**A.2. Site Conditions and History**

Currently, existing buildings and pavements occupy the much of the site. The southeastern portion of the proposed site is occupied by 2 small commercial buildings and their pavements, while the remainder of the site is occupied by existing Friendship Village residential buildings and pavements. An existing pond will be partially filled in to allow construction of the proposed Residential Living building.

Current grades range from 883 to 850. Generally, the highest elevations are in the western portions of the site and slope downwards to the east.

Photograph 1. Aerial Photograph of the Site in 2016



Photograph provided by Google.

### A.3. Purpose

The purpose of our geotechnical evaluation was to characterize subsurface geologic conditions at selected exploration locations and evaluate their impact on the design and construction of the proposed buildings and site improvements.

### A.4. Background Information and Reference Documents

We reviewed the following information:

- Surficial Geology Map of Hennepin County by Gary N. Meyer and Howard C. Hobbs, 1989.

- Schematic Grading plan prepared by Westwood Professional Services dated November 3, 2016.
- A Geotechnical Evaluation Report by Braun Intertec dated December 18, 2009. This report was performed for the Fitness Center Addition and Underground Parking.

In addition to the provided sources, we have used several publicly available sources of information.

We have described our understanding of the proposed construction and site to the extent others reported it to us. Depending on the extent of available information, we may have made assumptions based on our experience with similar projects. If we have not correctly recorded or interpreted the project details, the project team should notify us. New or changed information could require additional evaluation, analyses and/or recommendations.

#### **A.5. Scope of Services**

We performed our scope of services for the project in accordance with our Proposal for a Geotechnical Evaluation to Mr. Patrick Gleason of Greystone Communities, dated October 12, 2016. The following list describes the geotechnical tasks completed in accordance with our authorized scope of services.

- Reviewing the background information and reference documents previously cited.
- Staking and clearing the exploration location of underground utilities. SAS Architects and Planners, LLC selected and we staked the new exploration locations. We acquired the surface elevations and locations with GPS technology using the State of Minnesota's permanent GPS base station network. The Soil Boring Location Sketch included in the Appendix shows the approximate locations of the borings.
- Performing 22 standard penetration test (SPT) borings, denoted as ST-1 to ST-22, to nominal depths of 21 to 51 feet below grade across the site.
- Performing laboratory testing on select samples to aid in soil classification and engineering analysis.

- Perform engineering analysis including settlement analysis, bearing capacity evaluation and pavement design.
- Preparing this report containing a boring location sketch, logs of soil borings, a summary of the soils encountered, results of laboratory tests, and recommendations for structure and pavement subgrade preparation and the design of foundations, floor slabs, exterior slabs, utilities, stormwater improvements and pavements.

Our scope of services did not include environmental services or testing, and the personnel performing the evaluation are not trained to provide environmental services or testing. We can provide these services or testing at your request.

## **B. Results**

### **B.1. Geologic Overview**

The native soils at this site consist of glacial till soils of mixed composition. The glacial soils consist of loam and sandy loam intermixed with layers of sand.

We based the geologic origins used in this report on the soil types, in-situ and laboratory testing, and available common knowledge of the geological history of the site. Because of the complex depositional history, geologic origins can be difficult to ascertain. We did not perform a detailed investigation of the geologic history for the site.

### **B.2. Previous Geotechnical Information**

We performed soil borings on this site as recently as 2009. Those previous borings typically encountered pavements and previously placed fill soils overlying localized alluvial soils before encountering and terminating in glacial soils. The glacial soils consisted of interbedded layers of glacial till and glacial outwash. The glacial till soils typically consisted of silty sand, clayey sand and sandy lean clay. The glacial outwash soils consisted of poorly graded sand and poorly graded sand with silt.

### B.3. Boring Results

Table 3 provides a summary of the soil boring results, in the general order we encountered the strata. Please refer to the Log of Boring sheets in the Appendix for additional details. The Descriptive Terminology sheets in the Appendix include definitions of abbreviations used in Table 3. Note that we consider soils described as moist to be near or below their probable optimum moisture content. Soils described as wet are considered to be above their probable optimum moisture content. Soils described as waterbearing are considered to be approaching saturation.

**Table 3. Subsurface Profile Summary\***

Strata	Soil Type - ASTM Classification	Range of Penetration Resistances	Commentary and Details
Pavement section	NA	NA	<ul style="list-style-type: none"> <li>▪ Overall thickness ranges from 9 to 13 inches.</li> <li>▪ Bituminous thickness 2 to 4 inches.</li> <li>▪ Aggregate base thickness is 5 to 11 inches.</li> </ul>
Topsoil (fill or native)	Silty sand, clayey sand, lean clay and organic clay	NA	<ul style="list-style-type: none"> <li>▪ Dark brown to black.</li> <li>▪ Thicknesses at boring locations varied from 4 to 24 inches.</li> <li>▪ Moisture condition generally wet.</li> </ul>
Fill	Silty sand, clayey sand and lean clay	3 to 26 BPF	<ul style="list-style-type: none"> <li>▪ General penetration resistance of 6 to 12 BPF.</li> <li>▪ Moisture condition generally moist, but locally wet.</li> <li>▪ Thicknesses at boring locations varied from 4 to 9 feet.</li> <li>▪ ST-7 contained traces of wood debris between 4 and 7 feet.</li> </ul>
Glacial deposits	SP, SP-SM, SM, ML	4 to 30 BPF	<ul style="list-style-type: none"> <li>▪ General penetration resistance of 9 to 15 BPF.</li> <li>▪ Intermixed layers of glacial outwash and till.</li> <li>▪ Moisture condition generally moist but locally wet, particularly at depth.</li> </ul>
	SC, CL,	3 to 25 BPF	

\*Abbreviations defined in the attached Descriptive Terminology sheets.

For simplicity in this report, we define fill to mean existing, uncontrolled or undocumented fill.

## B.4. Groundwater

Table 4 summarizes the depths where we observed groundwater; the attached Log of Boring sheets in the Appendix also include this information and additional details.

**Table 4. Groundwater Summary**

Location	Surface Elevation	Measured or Estimated Depth to Groundwater (ft)	Corresponding Groundwater Elevation (ft)
ST-5	869.8	40	830
ST-12	858.9	20	839
ST-15	858.3	24	834 1/2
ST-16	851.2	12	839
ST-17	850.7	9	842
ST-18	851.7	7 ½	844 1/2
ST-19	854.1	15	839
ST-20	871.5	15	856 1/2

The elevations of the water levels observed in the borings typically varied from elevation 844 ½ to 830, with the elevation in ST-20 of 856 1/2. Based on our previous experience at this site, as well as the soil borings that have a layered soil profile, perched water conditions exist across this site. Determining the actual groundwater elevation would require long term monitoring of piezometers.

Project planning should expect that the groundwater elevations will fluctuate seasonally and annually. Perched groundwater is particularly sensitive to precipitation amounts and can vary significantly in terms of both elevation at which it is encountered as well as volume after unusually wet or dry years.

## B.5. Laboratory Test Results

The moisture content of the soils in the upper 10 to 15 feet were typically less than 14 percent, indicating most of those soils were near or below their probable optimum moisture contents. Moisture contents tended to increase with depth indicating that the soils below the upper 10 to 15 feet were typically above their probable optimum moisture content.

The results of our mechanical analyses and Atterberg limits were performed to aid in soil classification, as well as our analysis, and are shown on the boring logs.

## **C. Recommendations**

### **C.1. Design and Construction Discussion**

#### **C.1.a. Building Subgrade Preparation**

The new buildings will require the demolition of several existing buildings. All foundations, slabs, pavements and utilities associated with those structures must be removed completely from within the footprint of the new buildings and their oversize areas. If excavations to remove those structures extend below the planned subgrade elevations for the new buildings, those excavations should be backfilled and compacted with structural backfill as defined in this report.

Surface vegetation, root zones, topsoil and soils with an organic content greater than 3 percent must be removed below the new buildings. Those materials should either be placed in landscape areas or be hauled off-site.

The fill soils encountered by the borings had variable penetration resistance values and locally contained debris or concealed buried topsoil. The fill soils are not considered to be suitable for support of the new buildings and should be removed and replaced with structural backfill. The fill soils that contain an organic content less than 3 percent, do not contain debris and are within the recommended moisture range may be reused as structural fill within the proposed building pads.

The native soils are considered generally suitable for the support of the new buildings. However, portions of the native soils are overly wet, soft or loose and will require some preparation to be suitable for structural support. Loose sands should be surface compacted prior to the placement of structural fill, foundations or slabs. Over wet and soft silty and clayey soils should either be scarified and dried to near their optimum moisture content or be removed and replaced with suitable structural fill.

We are anticipating performing additional borings within the existing pond later this winter when the pond freezes. The ice will need to be at least 24 inches thick to support our drill rig. If the ice is at least 12 inches thick, we could perform hand auger borings, but will only be able to reach depths of 5 to 8 feet.

Based on our experiences with other ponds, we assume that there will be 1 to 3 feet of sediment on the bottom of the pond. That sediment will not be suitable for support of the proposed building and fill soils required below the proposed building. The sediment must be handled in accordance with the Minnesota Pollution Control Agency (MPCA) Guidelines. Those guidelines require that the sediment must be analyzed prior to excavation. We recommend obtaining samples of the sediment when we perform our borings and running the required analytical tests then. We can provide a cost estimate to provide those services, which are not covered in our Geotechnical Scope. Further information regarding managing sediment can found at the following link:

<https://www.pca.state.mn.us/sites/default/files/wq-strm4-16.pdf>

#### **C.1.b. Groundwater**

Based on the recent borings and our previous work on site, it should be anticipated that perched water will be encountered at various elevations during excavations on this site. Within the silty and clayey soils, sumps and pumps should be adequate to dewater excavations. Within poorly graded sands and poorly graded sand with silt, dewatering wells will likely be required to dewater excavations. We recommend having a dewatering contractor review our logs to assist the General Contractor when preparing dewatering plans.

We also recommend that the below grade walls be waterproofed and installing drain tile along the perimeter footings. The drain tile should be routed to the storm sewer system to prevent water from accumulating against the below grade walls. Note that the drain tile may require the use of a pump if it cannot be drained via a gravity line.

#### **C.1.c. Reuse of On-Site Soils**

The fill soils that contain an organic content less than 3 percent, do not contain debris and are within the recommended moisture range may be reused as structural fill within the proposed building pads and pavement areas. Note that portions of the fill soils were overly wet and will require drying to be reused as structural fill.

The native soils may be reused as structural fill within the proposed building pads and pavement areas. Note that portions of the native soils, particularly below the upper 10 to 15 feet, were wet and will require drying to be reused as structural fill.

Given that much of the site is already developed and there appears to be limited areas where soils could be spread out and dried, it may not be possible to dry out overly wet soils.

**C.1.d. Pavement**

Any foundations, slabs, pavements and utilities associated with those structures must be removed completely from the upper 3 feet of the pavement subgrades. At depths below the upper 3 feet, it is our opinion that those items may remain in place provided they are abandoned in accordance with all applicable regulations and the soils above them are stable.

Surface vegetation and root zones, topsoil and soils with an organic content greater than 3 percent must be removed within the upper 3 feet of pavement subgrades. Provided the Owner is willing to accept some risk of long-term settlement, topsoil and soils with an organic content greater than 3 percent may remain in place below the upper 3 feet of the pavement subgrade provided the soils above them are stable.

After removing any structures, utilities, surface vegetation and root zones, the exposed subgrade soils should be scarified to a depth of 8 inches, moisture conditioned to near their optimum moisture contents and be compacted prior to the placement of fill or pavement materials. If the soils cannot be stabilized via that procedure, than additional measures such as deeper scarification and moisture conditioning or removal and replacement of those soils will be required.

**C.1.e. Temporary Retention**

Portions of the proposed buildings will be rather close to existing buildings, roads and utilities that will remain in place and operational during construction. At this point, the drawings provided to us are schematic, so exact distances are not known at this time. However, if there is insufficient room to safely slope excavations during construction to prevent damage to existing structures, than temporary retention could be required.

**C.1.f. Stormwater**

The soils on this site consist of intermixed layers of silty sand, clayey sand, sandy lean clay, silt, poorly graded sand with silt and poorly graded sand. Those layers are not continuous across the site and exist at varying elevations. Those soils will have highly variable, and often low, infiltration rates. Please see section C.10. for further discussion on this topic.

## C.2. Site Grading and Subgrade Preparation

### C.2.a. Building Subgrade Excavations

We recommend removing unsuitable materials from within the proposed building pads and oversize areas. We define unsuitable materials as surface vegetation, root zones, existing fill, frozen materials, organic soils, existing structures, existing utilities and overly soft or loose soils. Table 5 shows the anticipated excavation depths and bottom elevations for the borings within or near the proposed buildings. Note that we assume that both buildings will have parking below the entire footprint with subgrade elevations approximately 1 foot below the lowest floor elevation listed in Table 1 (Elevation 847.5 for MS & AL and Elevation 850 for Residential Living).

**Table 5. Building Excavation Depths**

Location	Boring #	Approximate Surface Elevation (ft)	Anticipated Excavation Depth (ft)	Anticipated Bottom Elevation (ft)
MS & AL	ST-2	865.1	17 1/2	847 1/2
MS & AL	ST-3	864.2	17	847 1/2
MS & AL	ST-4	870.8	23 ½	847 1/2
MS & AL	ST-5	869.8	22 1/2	847 1/2
MS & AL	ST-6	871.7	24 ½	847 1/2
MS & AL	ST-7	871.1	24	847 1/2
MS & AL	ST-9	858.2	14	844
MS & AL	ST-11	860.3	13	847 1/2
MS & AL	ST-12	858.9	11 1/2	847 1/2
MS & AL	ST-14	858.7	11 1/2	847 1/2
MS & AL	ST-21	856.8	9 1/2	847 1/2
MS & AL	ST-22	873.9	26 ½	847 1/2
Residential Living	ST-15	858.3	8 1/2	850
Residential Living	ST-16	851.2	9	842
Residential Living	ST-17	850.7	4	846 1/2
Residential Living	ST-18	851.7	4	844 1/2

Location	Boring #	Approximate Surface Elevation (ft)	Anticipated Excavation Depth (ft)	Anticipated Bottom Elevation (ft)
Residential Living	ST-19	854.1	4	850
Residential Living	ST-20	871.5	21 1/2	850

Excavation depths will vary between the borings. Portions of the excavations may also extend deeper than indicated by the borings. A geotechnical representative should observe the excavations to make the necessary field judgments regarding the suitability of the exposed soils.

The contractor should use equipment and techniques to minimize soil disturbance. If soils become disturbed or are wet, we recommend excavation and replacement/mud slab/surface compaction/etc.

#### **C.2.b. Excavation Oversizing**

When removing unsuitable materials below structures or pavements, we recommend the excavation extend outward and downward at a slope of 1H:1V (horizontal: vertical) or flatter. See Figure 1 for an illustration of excavation oversizing.

Figure 1. Generalized Illustration of Oversizing

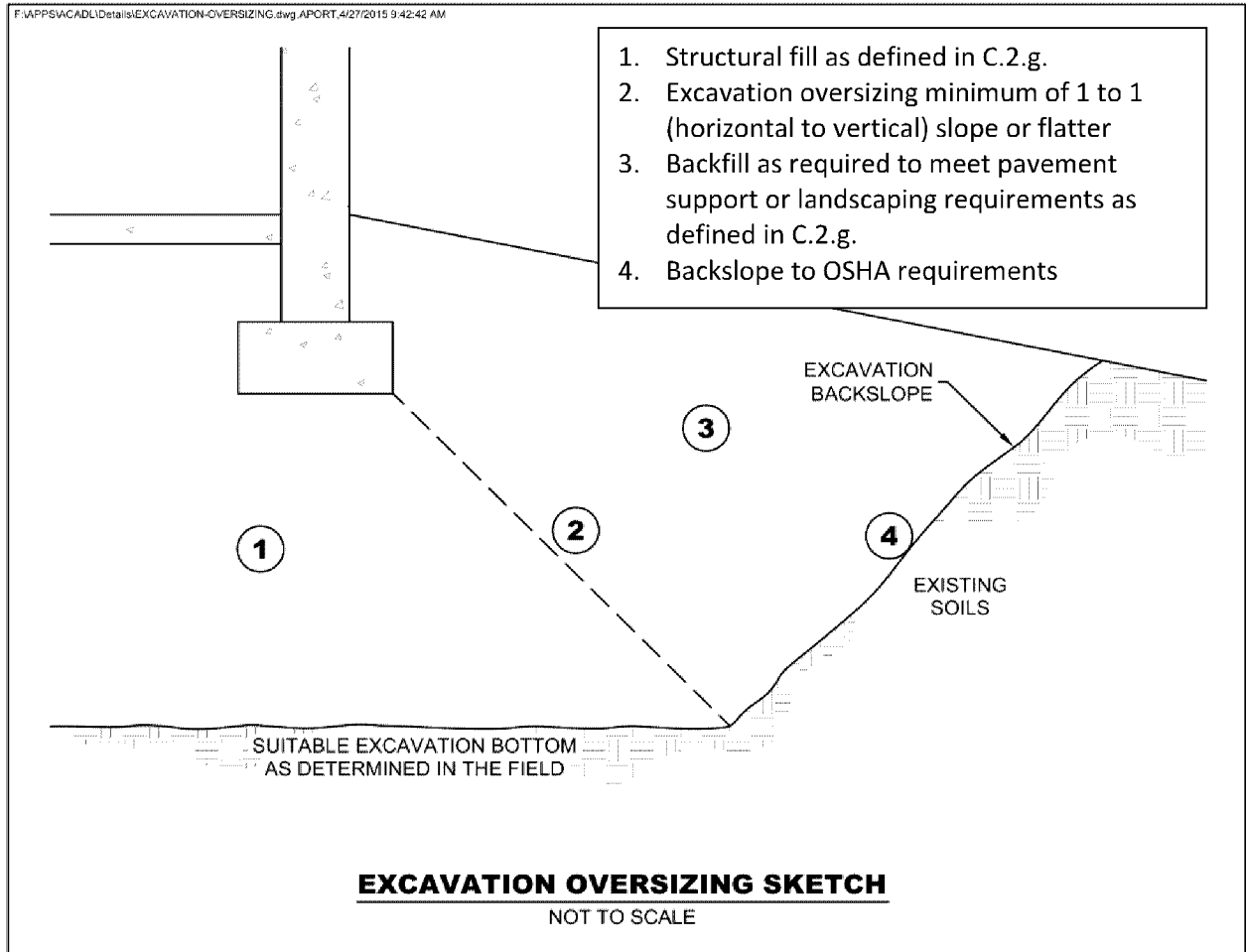

### C.2.c. Excavated Slopes

Based on the borings, we anticipate on-site soils in excavations will consist of intermixed glacial soils. The fill and cohesionless (non clay) soils are typically considered Type C Soil under OSHA (Occupational Safety and Health Administration) guidelines. OSHA guidelines indicate unsupported excavations in Type C soils should have a gradient no steeper than 1 ½ H:1V. Slopes constructed in this manner may still exhibit surface sloughing. OSHA requires an engineer to evaluate slopes or excavations over 20 feet in depth. Clay soils are considered to be Type B soils should have a gradient no steeper than 1H:1V.

An OSHA-approved qualified person should review the soil classification in the field. Excavations must comply with the requirements of OSHA 29 CFR, Part 1926, Subpart P, "Excavations and Trenches." This document states excavation safety is the responsibility of the contractor. The project specifications should reference these OSHA requirements.

**C.2.d. Excavation Dewatering**

We recommend removing groundwater from the excavations. Project planning should include temporary sumps and pumps for excavations in low-permeability soils, such as clays. Dewatering of high-permeability soils (e.g., sands) from within the excavation with conventional pumps has the potential to loosen the soils, due to upward flow. A well contractor should develop a dewatering plan; the design team should review this plan.

**C.2.e. Pavement and Exterior Slab Subgrade Preparation**

We recommend the following steps for pavement and exterior slab subgrade preparation. Note that project planning may need to require additional subcuts to limit frost heave.

1. Strip unsuitable soils consisting of topsoil, organic soils, vegetation, existing structures and pavements from the area, within 3 feet of the surface of the proposed pavement grade.
2. Scarify to a depth of at least 8 inches, moisture condition and surface compact the subgrade to at least 95 percent of standard Proctor density below the upper 3 feet of the pavement subgrade or 100 percent of standard Proctor density in the upper 3 feet.
3. Have a geotechnical representative observe the excavated subgrade to evaluate if additional subgrade improvements are necessary.
4. Place pavement fill to grade and compact in accordance with Section C.2.g to bottom of pavement and exterior slab section. See Section C.7 for additional considerations related to frost heave.
5. Proofroll the pavement or exterior slab subgrade as described in Section C.2.f.

**C.2.f. Pavement Subgrade Proofroll**

After preparing the subgrade as described above and prior to the placement of the aggregate base, we recommend proofrolling the subgrade soils with a fully loaded tandem-axle truck. We also recommend having a geotechnical representative observe the proofroll. Areas that fail the proofroll likely indicate soft or weak areas that will require additional soil correction work to support pavements.

The contractor should correct areas that display excessive yielding or rutting during the proofroll, as determined by the geotechnical representative. Possible options for subgrade correction include moisture conditioning and recompaction, subcutting and replacement with soil or crushed aggregate, chemical stabilization and/or geotextiles. We recommend performing a second proofroll after the aggregate base material is in place, and prior to placing bituminous or concrete pavement.

**C.2.g. Fill Materials and Compaction**

Table 6 below contains our recommendations for fill materials.

**Table 6. Fill Materials\***

Locations To Be Used	Fill Classification	Possible Soil Type Descriptions	Gradation	Additional Requirements
<ul style="list-style-type: none"> <li>▪ Below foundations</li> <li>▪ Below interior slabs</li> </ul>	Structural fill	SP, SP-SM, SM, SC, CL	100% passing 2-inch sieve	< 3% Organic Content (OC) Plasticity Index (PI) < 15%
<ul style="list-style-type: none"> <li>▪ Drainage layer</li> <li>▪ Non-frost-susceptible</li> </ul>	<ul style="list-style-type: none"> <li>▪ Free-draining</li> <li>▪ Non-frost-susceptible fill</li> </ul>	GP, GW, SP, SW	100% passing 1-inch sieve < 50% passing #40 sieve < 5% passing #200 sieve	< 2% OC
Behind below-grade walls, beyond drainage layer	Retained fill	SP, SW, SP-SM, SW-SM, SM	100% passing 3-inch sieve < 20% passing #200 sieve	< 3% OC PI < 4%
Pavements	Pavement fill	SP, SM, SC, CL	100% passing 3-inch sieve	< 2% OC PI < 15%
Below landscaped surfaces, where subsidence is not a concern	Non-structural fill		100% passing 6-inch sieve	< 10% OC

\* More select soils comprised of coarse sands with < 5% passing #200 sieve may be needed to accommodate work occurring in periods of wet or freezing weather.

We recommend spreading fill in loose lifts of approximately 8 inches thick. We recommend compacting fill in accordance with the criteria presented below in Table 7. The project documents should specify relative compaction of fill, based on the structure located above the fill, and vertical proximity to that structure.

**Table 7. Compaction Recommendations Summary**

Reference	Relative Compaction, percent (ASTM D698 – Standard Proctor) (ASTM D1557 – Modified Proctor)	Moisture Content Variance from Optimum, percentage points	
		< 12% Passing #200 Sieve (typically SP, SP-SM)	> 12% Passing #200 Sieve (typically CL, SC, ML, SM)
Below foundations and oversized zones	98	±3	-1 to +3
Below interior slabs	98	±3	-1 to +3
Within 3 feet of pavement subgrade	100	±3	-1 to +3
More than 3 feet below pavement subgrade	95	±3	±3
Below landscaped surfaces	90	±5	±4
Adjacent to below-grade wall	95*	±3	-1 to +3

\*Increase compaction requirement to meet compaction required for structure supported by this fill.

The project documents should not allow the contractor to use frozen material as fill or to place fill on frozen material. Frost should not penetrate under foundations during construction.

We recommend performing density tests in fill to evaluate if the contractors are effectively compacting the soil and meeting project requirements.

**C.2.h. Special Inspections of Soils**

We recommend including the site grading and placement of fill within the building pad under the direction of Special Inspections, as provided in Chapter 17 of the International Building Code, which is adopted into the state building code. Special Inspection requires observation of soil conditions below fill or footings, evaluations to determine if excavations extend to the anticipated soils, and if fill materials meet requirements for type of fill and compaction condition of fill. A licensed geotechnical engineer should direct the Special Inspections of site grading and fill placement. The purpose of these Special Inspections is to evaluate whether the work is in accordance with the approved Geotechnical Report for the project. Special Inspections should include evaluation of the subgrade, observing preparation of the subgrade (surface compaction or dewatering, excavation oversized, placement procedures and materials used for fill, etc.) and compaction testing of the fill.

### C.3. Spread Footings

Table 8 below contains our recommended parameters for foundation design.

**Table 8. Recommended Spread Footing Design Parameters**

Item	Description
Maximum net allowable bearing pressure (psf)	3,000
Minimum factor of safety for bearing capacity failure	3.0
Minimum width (inches)	24
Minimum embedment below final exterior grade for heated structures (inches)	42
Minimum embedment below final exterior grade for unheated structures or for footings not protected from freezing temperatures during construction (inches)	60
Total estimated settlement (inches)	1
Differential settlement	Typically about 2/3 of total settlement*

\* Actual differential settlement amounts will depend on final loads and foundation layout. When tying into the existing buildings, the total settlement of this new building will be differential to the existing building. We can evaluate differential settlement based on final foundation plans and loadings.

### C.4. Construction Adjacent to Existing Structures

#### C.4.a. Excavations

Excavations for the new buildings may extend near or below existing footing grades. To reduce the risk of undermining the existing foundations, we recommend excavations do not extend within the 1:1 slope away from the edge of existing footings. After reaching the design depth, a geotechnical representative should observe the excavation bottom to evaluate the suitability of the soils near the existing foundation for support of the new floor slab and foundation. We recommend contacting us if excavations need to extend beyond the limits described above, as additional improvements such as ground improvement, retention or underpinning may be warranted.

During construction, the contractor should monitor the slope and structure for movement. We also recommend protecting the slope from disturbance, such as precipitation, runoff or sloughing. The project team should establish threshold limits of movement and required action, if the movement exceeds the limits.

#### **C.4.b. Footing Depth**

New building foundations constructed adjacent to the foundations of the existing building may exert additional stresses on existing foundations. In general, we recommend constructing new foundations to bear at the same elevation as the existing foundations. We also recommend lowering or offsetting foundations so a foundation or its oversize zone does not exert a load on adjacent structures.

#### **C.5. Below-Grade Walls**

For walls with unbalanced fill loads, we recommend the fill located within 5 feet of the walls consist of a drainage layer and then retained fill as defined in Table 6.

We recommend designing the walls based on soils having an equivalent fluid pressure of 40 pounds per cubic foot (pcf) for active pressure, and 60 pcf for at-rest earth pressure. Designs should also consider the slope of any fill and dead or live loads, including equipment and materials, placed within a horizontal distance behind the walls that is equal to the height of the walls. Our recommended values also assume the wall design provides drainage to prevent water from accumulating behind the walls. The construction documents should clearly identify the material properties of the soil the contractor should use for wall fill.

The project documents should indicate if walls need bracing prior to filling and allowable unbalanced fill heights.

##### **C.5.a. Drainage Control**

We recommend installing drain tile to remove water behind the below-grade walls, at the location shown in Figure 2. The below-grade wall drainage system should also incorporate free-draining fill or a drainage board placed against the wall and connected to the drain tile.

Even with the use of free-draining fill, we recommend general waterproofing of below-grade walls that surround occupied or potentially occupied areas because of the potential cost impacts related to seepage after construction is complete.

Figure 2. Generalized Illustration of Wall Backfill

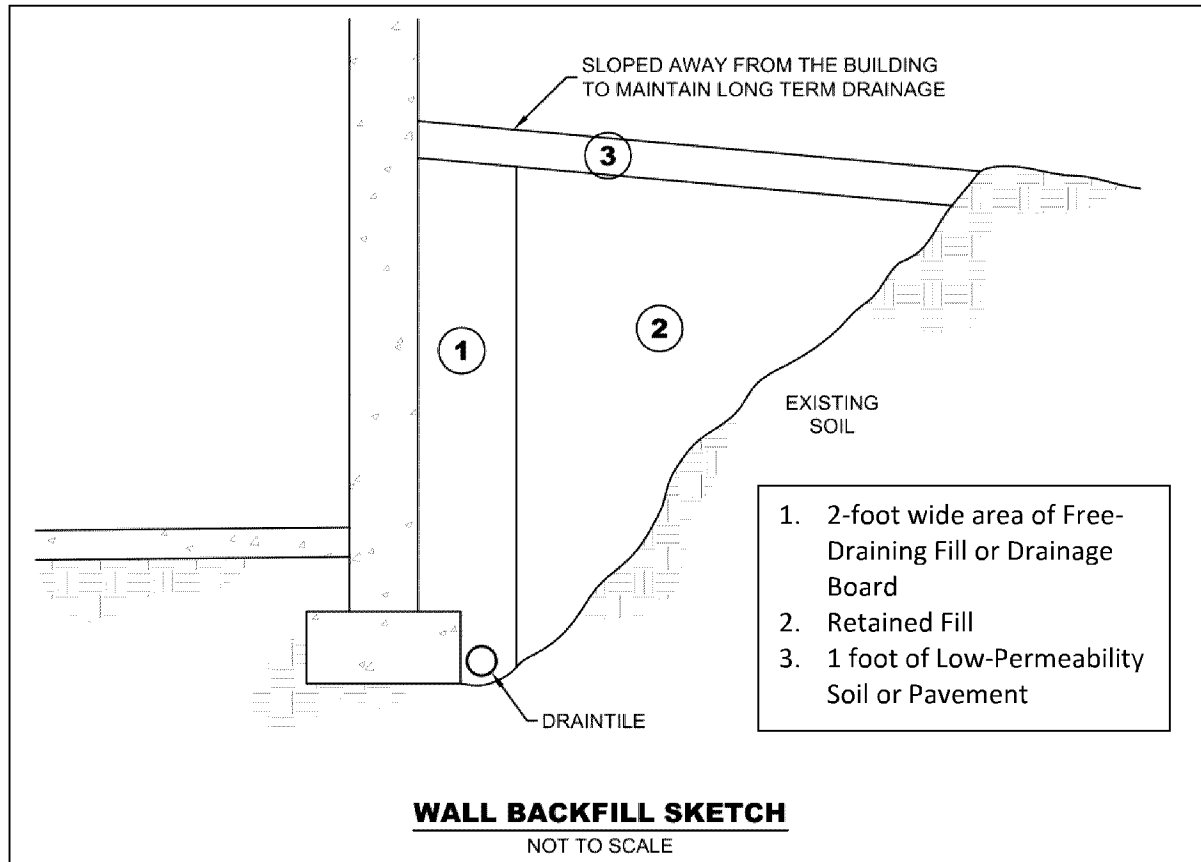

The materials listed in the sketch should meet the definitions in Section C.2.g. Low-permeability material is capable of directing water away from the wall, like clay, topsoil or pavement. The project documents should indicate if the contractor should brace the walls prior to filling and allowable unbalanced fill heights.

As shown in Figure 2, we recommend Zone 2 consist of retained fill, and this material will control lateral pressures on the wall. However, we are also providing design parameters for using other fill material. If final design uses non-sand material for fill, project planning should account for the following items:

- Other fill material may result in higher lateral pressure on the wall.
- Other fill material may be more difficult to compact.

- Post-construction consolidation of other fill material may result in settlement-related damage to the structures or slabs supported on the fill. Post-construction settlement of other fill material may also cause drainage towards the structure. The magnitude of consolidation could be up to about 3 percent of the wall fill thickness.

**C.5.b. Configuring and Resisting Lateral Loads**

Below-grade wall design can use active earth pressure conditions, if the walls can rotate slightly. If the wall design cannot tolerate rotation, then design should use at-rest earth pressure conditions. Rotation up to 0.002 times the wall height is generally required for walls supporting sand. Rotation up to 0.02 times the wall height is required when wall supports clay.

Table 9 presents our recommended lateral coefficients and equivalent fluid pressures for wall design of active, at-rest and passive earth pressure conditions. The table also provides recommended wet unit weights and internal friction angles. Designs should also consider the slope of any fill and dead or live loads placed behind the walls within a horizontal distance that is equal to the height of the walls. Our recommended values assume the wall design provides drainage so water cannot accumulate behind the walls. The construction documents should clearly identify what soils the contractor should use for the fill of walls.

**Table 9. Recommended Below-Grade Wall Design Parameters – Drained Conditions**

Retained Soil	Wet Unit Weight, pcf	Friction Angle, degrees	Active Lateral Coefficient/ Equivalent Fluid Pressure* (pcf)	At-Rest Lateral Coefficient/ Equivalent Fluid Pressure* (pcf)	Passive Lateral Coefficient/ Equivalent Fluid Pressure* (pcf)
Retained Fill	120	30	0.33/40	0.5/60	3.0/360

\* Based on Rankine model for soils in a region behind the wall extending at least 2 horizontal feet beyond the bottom outer edges of the wall footings and then rising up and away from the wall at an angle no steeper than 60 degrees from horizontal.

Sliding resistance between the bottom of the footing and the soil can also resist lateral pressures. We recommend assuming a sliding coefficient equal to 0.45 between the concrete and soil.

The values presented in this section are un-factored.

## **C.6. Interior Slabs**

### **C.6.a. Subgrade Modulus**

The anticipated floor subgrade is native silty and clayey glacial soils. We recommend using a modulus of subgrade reaction,  $k$ , of 150 pounds per square inch per inch of deflection (pci) to design the slabs. If the slab design requires placing 6 inches of compacted crushed aggregate base immediately below the slab, the slab design may increase the  $k$ -value by 50 pci. We recommend that the aggregate base materials be free of bituminous. In addition to improving the modulus of subgrade reaction, an aggregate base facilitates construction activities and is less weather sensitive.

### **C.6.b. Moisture Vapor Protection**

Excess transmission of water vapor could cause floor dampness, certain types of floor bonding agents to separate, or mold to form under floor coverings. If project planning includes using floor coverings or coatings, we recommend placing a vapor retarder or vapor barrier immediately beneath the slab. We also recommend consulting with floor covering manufacturers regarding the appropriate type, use and installation of the vapor retarder or barrier to preserve warranty assurances.

## **C.7. Frost Protection**

### **C.7.a. General**

Silty sand, clayey sand and sandy lean clay will underlie all or some of the exterior slabs, as well as pavements. We consider those soils to be moderately to highly frost susceptible. Soils of this type can retain moisture and heave upon freezing. In general, this characteristic is not an issue unless these soils become saturated, due to surface runoff or infiltration, or are excessively wet in situ. Once frozen, unfavorable amounts of general and isolated heaving of the soils and the surface structures supported on them could develop. This type of heaving could affect design drainage patterns and the performance of exterior slabs and pavements, as well as any isolated exterior footings and piers.

Note that general runoff and infiltration from precipitation are not the only sources of water that can saturate subgrade soils and contribute to frost heave. Roof drainage and irrigation of landscaped areas in close proximity to exterior slabs, pavements, and isolated footings and piers, contribute as well.

**C.7.b. Frost Heave Mitigation**

To address most of the heave related issues, we recommend setting general site grades and grades for exterior surface features to direct surface drainage away from buildings, across large paved areas and away from walkways. Such grading will limit the potential for saturation of the subgrade and subsequent heaving. General grades should also have enough “slope” to tolerate potential larger areas of heave, which may not fully settle after thawing.

Even small amounts of frost-related differential movement at walkway joints or cracks can create tripping hazards. Project planning can explore several subgrade improvement options to address this condition.

One of the more conservative subgrade improvement options to mitigate potential heave is removing any frost-susceptible soils present below the exterior slab areas down to a minimum depth of \_ feet below subgrade elevations. We recommend filling the resulting excavation with non-frost-susceptible fill. We also recommend sloping the bottom of the excavation toward one or more collection points to remove any water entering the fill. This approach will not be effective in controlling frost heave without removing the water.

An important geometric aspect of the excavation and replacement approach described above is sloping the banks of the excavations to create a more gradual transition between the unexcavated soils considered frost susceptible and the excavation fill, which is not frost susceptible. The slope allows attenuation of differential movement that may occur along the excavation boundary. We recommend slopes that are 3H: 1V, or flatter, along transitions between frost-susceptible and non-frost-susceptible soils.

Figure 3 shows an illustration summarizing some of the recommendations.

Figure 3. Frost Protection Geometry Illustration

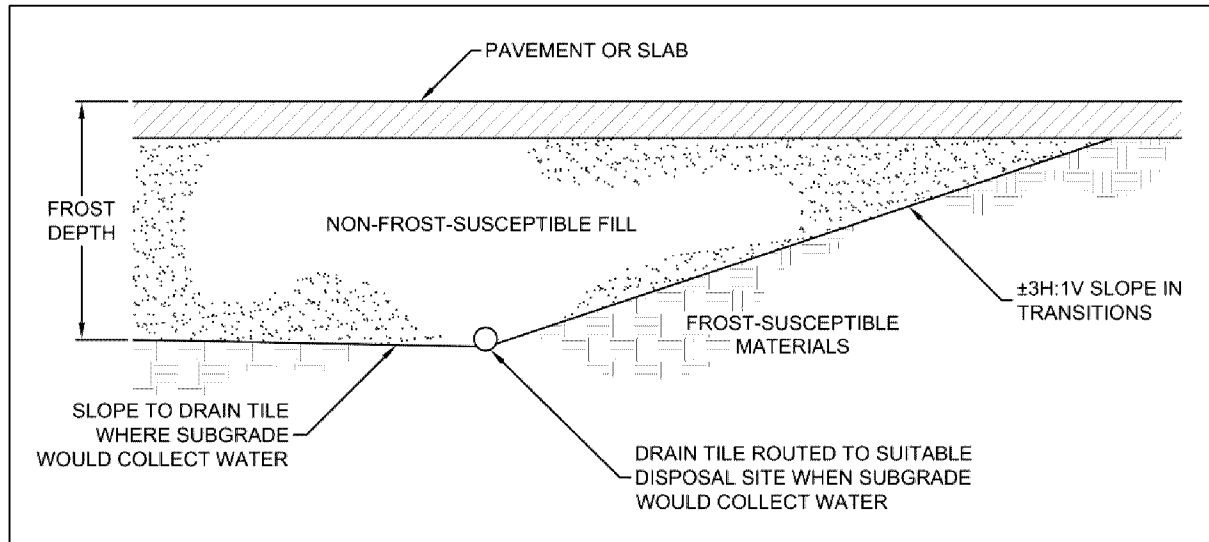

Another option is to limit frost heave in critical areas, such as doorways and entrances, via frost-depth footings or localized excavations with sloped transitions between frost-susceptible and non-frost-susceptible soils, as described above.

Over the life of slabs and pavements, cracks will develop and joints will open up, which will expose the subgrade and allow water to enter from the surface and either saturate or perch atop the subgrade soils. This water intrusion increases the potential for frost heave or moisture-related distress near the crack or joint. Therefore, we recommend implementing a detailed maintenance program to seal and/or fill any cracks and joints. The maintenance program should give special attention to areas where dissimilar materials abut one another, where construction joints occur and where shrinkage cracks develop.

## C.8. Pavements and Exterior Slabs

### C.8.a. Design Sections

Our scope of services for this project did not include laboratory tests on subgrade soils to determine an R-value for pavement design. Based on our experience with similar soils anticipated at the pavement subgrade elevation, we recommend pavement design assume an R-value of 25. Note the contractor may need to perform limited removal of unsuitable or less suitable soils to achieve this value. Table 10 provides recommended bituminous pavement sections, based on the soils support and traffic loads.

We based the concrete pavement designs on a modulus of subgrade reaction (k) of 150 pci.

**Table 10. Recommended Bituminous Pavement Sections**

Use	Parking	Drive Lanes
Minimum asphalt thickness (inches)	3.5	4.5
Minimum aggregate base thickness (inches)	10	10

**C.8.b. Bituminous Pavement Materials**

Appropriate mix designs are critical to the performance of flexible pavements. We can provide recommendations for pavement material selection during final pavement design.

**C.8.c. Concrete Pavements****Table 11. Recommended Concrete Pavement Sections**

Use	Sidewalks	Auto Parking	Heavy Duty
Minimum concrete thickness (inches)	4	5	6
Minimum aggregate base thickness (inches)	4	6	6

We assumed the concrete pavement sections in Table 11 will have edge support. We recommend placing an aggregate base below the pavement to provide a suitable subgrade for concrete placement, reduce faulting and help dissipate loads. Appropriate mix designs, panel sizing, jointing, doweling and edge reinforcement are critical to performance of rigid pavements. We recommend you contact your civil engineer to determine the final design or consult with us for guidance on these items.

**C.8.d. Subgrade Drainage**

We recommend installing perforated drainpipes throughout pavement areas at low points, around catch basins, and behind curb in landscaped areas. We also recommend installing drainpipes along pavement and exterior slab edges where exterior grades promote drainage toward those edge areas. The contractor should place drainpipes in small trenches, extended at least 8 inches below the aggregate base material.

**C.8.e. Performance and Maintenance**

We based the above pavement designs on a 20-year performance life for bituminous and a 30-year life for concrete. This is the amount of time before we anticipate the pavement will require reconstruction.

This performance life assumes routine maintenance, such as seal coating and crack sealing. The actual pavement life will vary depending on variations in weather, traffic conditions and maintenance.

It is common to place the non-wear course of bituminous and then delay placement of wear course. For this situation, we recommend evaluating if the reduced pavement section will have sufficient structure to support construction traffic.

Many conditions affect the overall performance of the exterior slabs and pavements. Some of these conditions include the environment, loading conditions and the level of ongoing maintenance. With regard to bituminous pavements in particular, it is common to have thermal cracking develop within the first few years of placement, and continue throughout the life of the pavement. We recommend developing a regular maintenance plan for filling cracks in exterior slabs and pavements to lessen the potential impacts for cold weather distress due to frost heave or warm weather distress due to wetting and softening of the subgrade.

## **C.9. Utilities**

### **C.9.a. Subgrade Stabilization**

Earthwork activities associated with utility installations located inside the building footprint should adhere to the recommendations in Section C.2.

For exterior utilities, we anticipate the soils at typical invert elevations will be suitable for utility support. However, if construction encounters unfavorable conditions such as soft clay, organic soils or perched water at invert grades, the unsuitable soils may require some additional subcutting and replacement with sand or crushed rock to prepare a proper subgrade for pipe support. Project design and construction should not place utilities within the 1H:1V oversizing of foundations.

### **C.9.b. Corrosion Potential**

Based on our experience, the soils encountered by the borings are moderately corrosive to metallic conduits, but only marginally corrosive to concrete. We recommend specifying non-corrosive materials or providing corrosion protection, unless project planning chooses to perform additional tests to demonstrate the soils are not corrosive.

## C.10. Stormwater

We estimated infiltration rates for some of the soils we encountered in our soil borings, as listed in Table 12. These infiltration rates represent the long-term infiltration capacity of a practice and not the capacity of the soils in their natural state. Field testing, such as with a double-ring infiltrometer (ASTM D3385), may justify the use of higher infiltration rates. However, we recommend adjusting field test rates by the appropriate correction factor, as provided for in the Minnesota Stormwater Manual or as allowed by the local watershed. We recommend consulting the Minnesota Stormwater Manual for stormwater design.

**Table 12. Estimated Design Infiltration Rates Based on Soil Classification**

Soil Type	Infiltration Rate * (inches/hour)
Gravels and gravelly sands	1.63
Sands with less than 12% fines, poorly graded or well graded sands	0.8
Silty sands, silty gravelly sands	0.45
Silts, very fine sands, silty or clayey fine sands	0.2
Clayey sands and clays	0.06

\* From Minnesota Stormwater Manual. Rates may differ at individual sites.

Fine-grained soils (silts and clays), topsoil or organic matter that mixes into or washes onto the soil will lower the permeability. The contractor should maintain and protect infiltration areas during construction. Furthermore, organic matter and silt washed into the system after construction can fill the soil pores and reduce permeability over time. Proper maintenance is important for long-term performance of infiltration systems.

This geotechnical evaluation does not constitute a review of site suitability for stormwater infiltration or evaluate the potential impacts, if any, from infiltration of large amounts of stormwater.

## C.11. Equipment Support

The recommendations included in the report may not be applicable to equipment used for the construction and maintenance of this project.

We recommend evaluating subgrade conditions in areas of shoring, scaffolding, cranes, pumps, lifts and other construction equipment prior to mobilization to determine if the exposed materials are suitable for equipment support, or require some form of subgrade improvement. We also recommend project planning consider the effect that loads applied by such equipment may have on structures they bear on or surcharge – including pavements, buried utilities, below-grade walls, etc. We can assist you in this evaluation.

## **D. Procedures**

### **D.1. Penetration Test Borings**

We drilled the penetration test borings with an all-terrain mounted core and auger drill equipped with hollow-stem auger. We performed the borings in general accordance with ASTM D1586 taking penetration test samples at 2 1/2- or 5-foot intervals. We collected thin-walled tube samples in general accordance with ASTM D1587 at selected depths. The boring logs show the actual sample intervals and corresponding depths. We also collected bulk samples of auger cuttings at selected locations for laboratory testing.

We sealed penetration test boreholes meeting the Minnesota Department of Health (MDH) Environmental Borehole criteria with an MDH-approved grout.

### **D.2. Exploration Logs**

#### **D.2.a. Log of Boring Sheets**

The Appendix includes Log of Boring sheets for our penetration test borings. The logs identify and describe the penetrated geologic materials, and present the results of penetration resistance tests performed.

We inferred strata boundaries from changes in the penetration test samples and the auger cuttings. Because we did not perform continuous sampling, the strata boundary depths are only approximate. The boundary depths likely vary away from the boring locations, and the boundaries themselves may occur as gradual rather than abrupt transitions.

### **D.2.b. Geologic Origins**

We assigned geologic origins to the materials shown on the logs and referenced within this report, based on: (1) a review of the background information and reference documents cited above, (2) visual classification of the various geologic material samples retrieved during the course of our subsurface exploration, (3) penetration resistance testing performed for the project, (4) laboratory test results, and (5) available common knowledge of the geologic processes and environments that have impacted the site and surrounding area in the past.

## **D.3. Material Classification and Testing**

### **D.3.a. Visual and Manual Classification**

We visually and manually classified the geologic materials encountered in accordance with ASTM D2488. The Appendix includes a chart explaining the classification system.

### **D.3.b. Laboratory Testing**

The exploration logs in the Appendix note most of the results of the laboratory tests performed on geologic material samples. The remaining laboratory test results follow the exploration logs. We performed the tests in general accordance with ASTM or AASHTO procedures.

## **D.4. Groundwater Measurements**

The drillers checked for groundwater while advancing the penetration test borings, and again after auger withdrawal. We then filled the boreholes or allowed them to remain open for an extended period of observation, as noted on the boring logs.

## **E. Qualifications**

### **E.1. Variations in Subsurface Conditions**

#### **E.1.a. Material Strata**

We developed our evaluation, analyses and recommendations from a limited amount of site and subsurface information. It is not standard engineering practice to retrieve material samples from exploration locations continuously with depth.

Therefore, we must infer strata boundaries and thicknesses to some extent. Strata boundaries may also be gradual transitions, and project planning should expect the strata to vary in depth, elevation and thickness, away from the exploration locations.

Variations in subsurface conditions present between exploration locations may not be revealed until performing additional exploration work, or starting construction. If future activity for this project reveals any such variations, you should notify us so that we may reevaluate our recommendations. Such variations could increase construction costs, and we recommend including a contingency to accommodate them.

### **E.1.b. Groundwater Levels**

We made groundwater measurements under the conditions reported herein and shown on the exploration logs, and interpreted in the text of this report. Note that the observation periods were relatively short, and project planning can expect groundwater levels to fluctuate in response to rainfall, flooding, irrigation, seasonal freezing and thawing, surface drainage modifications and other seasonal and annual factors.

## **E.2. Continuity of Professional Responsibility**

### **E.2.a. Plan Review**

We based this report on a limited amount of information, and we made a number of assumptions to help us develop our recommendations. We should be retained to review the geotechnical aspects of the designs and specifications. This review will allow us to evaluate whether we anticipated the design correctly, if any design changes affect the validity of our recommendations, and if the design and specifications correctly interpret and implement our recommendations.

### **E.2.b. Construction Observations and Testing**

We recommend retaining us to perform the required observations and testing during construction as part of the ongoing geotechnical evaluation. This will allow us to correlate the subsurface conditions exposed during construction with those encountered by the borings and provide professional continuity from the design phase to the construction phase. If we do not perform observations and testing during construction, it becomes the responsibility of others to validate the assumption made during the preparation of this report and to accept the construction-related geotechnical engineer-of-record responsibilities.

### **E.3. Use of Report**

This report is for the exclusive use of the addressed parties. Without written approval, we assume no responsibility to other parties regarding this report. Our evaluation, analyses and recommendations may not be appropriate for other parties or projects.

### **E.4. Standard of Care**

In performing its services, Braun Intertec used that degree of care and skill ordinarily exercised under similar circumstances by reputable members of its profession currently practicing in the same locality. No warranty, express or implied, is made.

## **Appendix**



<b>Braun Project B1610072</b> <b>GEOTECHNICAL EVALUATION</b> <b>Friendship Village</b> <b>Highwood Drive and Townline Road</b> <b>Bloomington, Minnesota</b>	BORING: <b>ST-1</b>
	LOCATION: See attached sketch.

DRILLER: B. Kammermeier	METHOD: 3 1/4" HSA, Autohammer	DATE: 10/27/16	SCALE: 1" = 4'
-------------------------	--------------------------------	----------------	----------------

Elev. feet	Depth feet	ASTM Symbol	Description of Materials (ASTM D2488 or D2487)	BPF	WL	MC %	Tests or Notes
863.9	0.0						
863.7	0.3	FILL SC	FILL: Silty Sand and Lean Clay, dark brown, wet. (Topsoil Fill)				
			CLAYEY SAND, with Sand lenses, trace Gravel, brown, wet, stiff to very stiff. (Glacial Till)	14		13	
				19			
				13			
854.9	9.0	CL	SANDY LEAN CLAY, trace Gravel, brown, wet, rather stiff. (Glacial Till)	11		13	
852.9	11.0	CL	SANDY LEAN CLAY, with Sand lenses, trace Gravel, brown, wet, rather stiff. (Glacial Till)	23		9	P200=35%
849.9	14.0	SM	SILTY SAND, fine- to medium-grained, trace Gravel, brown, moist, medium dense. (Glacial Till)	17			
842.9	21.0		END OF BORING.  Water not observed with 19 1/2 feet of hollow-stem auger in the ground.  Boring immediately backfilled.	18			

(See Descriptive Terminology sheet for explanation of abbreviations)

LOG OF BORING-DRAFT N:\GINT\PROJECTS\AX PROJECTS\2016\10072.GPJ BRAUN\_V8\_CURRENT.GDT 11/22/16 14:00

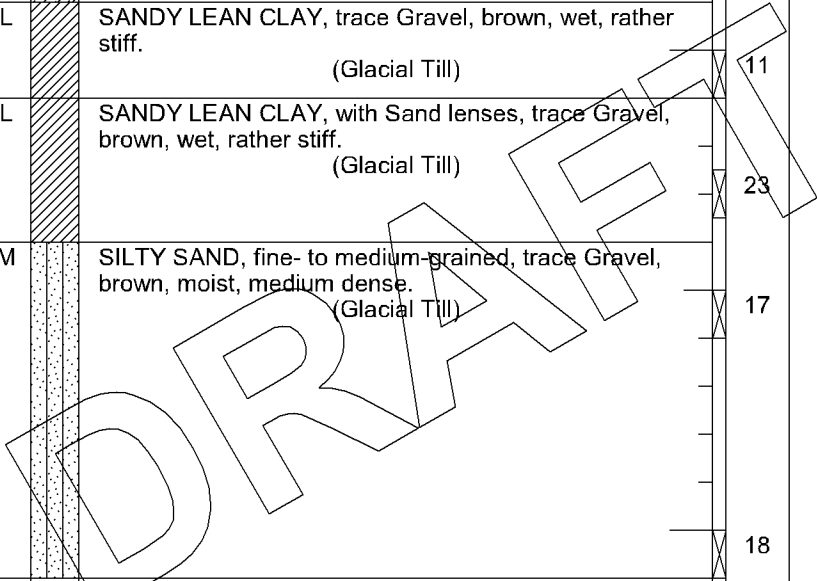

Braun Project B1610072 GEOTECHNICAL EVALUATION Friendship Village Highwood Drive and Townline Road Bloomington, Minnesota				BORING: <b>ST-2</b> LOCATION: See attached sketch.			
DRILLER: B. Kammermeier		METHOD: 3 1/4" HSA, Autohammer		DATE: 10/27/16		SCALE: 1" = 4'	
Elev. feet	Depth feet	ASTM Symbol	Description of Materials (ASTM D2488 or D2487)	BPF	WL	MC %	Tests or Notes
865.1	0.0						
864.7	0.4	FILL	FILL: Sandy Lean Clay, black, wet. (Topsoil Fill)				
		FILL	FILL: Silty Sand, fine- to medium-grained, with Clay lenses, with Gravel, brown to reddish brown, moist.	6		13	
861.1	4.0	SM	SILTY SAND, fine- to medium-grained, trace Gravel, brown, moist, loose to medium dense. (Glacial Till)	9			
				12		14	
				9			
				20			
				15			
847.1	18.0	CL	SANDY LEAN CLAY, with Gravel, brown, wet, very stiff to medium. (Glacial Till)	25			
				7			** Water not observed with 29 1/2 feet of hollow-stem auger in the ground.
837.1	28.0	SC	CLAYEY SAND, trace Gravel, gray, wet, stiff. (Glacial Till)				Boring immediately backfilled.
834.1	31.0			16			
			END OF BORING. **				

LOG OF BORING-DRAFT N:\GINT\PROJECTS\AX PROJECTS\2016\10072.GPJ BRAUN\_V8\_CURRENT.GDT 11/22/16 14:01

LOG OF BORING-DRAFT N:\GINT\PROJECTS\AX PROJECTS\2016\10072.GPJ BRAUN\_V8\_CURRENT.GDT 11/22/16 14:01

DRAFT

<b>Braun Project B1610072</b> <b>GEOTECHNICAL EVALUATION</b> <b>Friendship Village</b> <b>Highwood Drive and Townline Road</b> <b>Bloomington, Minnesota</b>	<b>BORING: ST-3</b>
	LOCATION: See attached sketch.

DRILLER: M. Belch	METHOD: 3 1/4" HSA, Autohammer	DATE: 10/25/16	SCALE: 1" = 4'
-------------------	--------------------------------	----------------	----------------

Elev. feet	Depth feet	ASTM Symbol	Description of Materials (ASTM D2488 or D2487)	BPF	WL	MC %	Tests or Notes
864.2	0.0						
863.5	0.7	FILL	FILL: Silty Sand, dark brown, moist. (Topsoil Fill)				
		FILL	FILL: Silty Sand, fine-grained, dark brown to brown, moist.				
				11		13	
				5			
857.2	7.0	CL	SANDY LEAN CLAY, with Sand lenses, trace Gravel, brown and gray, wet, rather stiff. (Glacial Till)	9		17	
855.2	9.0	SC	CLAYEY SAND, with Silt lenses, trace Gravel, brown, wet, medium. (Glacial Till)	6			
852.2	12.0	CL-ML	SILTY CLAY, brown, wet, rather stiff. (Glacial Till)	9		23	LL=18 PL=14 PI=4
850.2	14.0	SM	SILTY SAND, fine- to medium-grained, brown, moist, medium dense. (Glacial Till)	13			
846.2	18.0	CL	SANDY LEAN CLAY, trace Gravel, brown, wet, rather stiff. (Glacial Till)	10			
841.2	23.0	SM	SILTY SAND, fine- to medium-grained, with Clay seams, brown, moist, loose. (Glacial Till)	5			
836.2	28.0	SC	CLAYEY SAND, with Silt lenses, gray, wet, medium to rather stiff. (Glacial Till)	7			

(See Descriptive Terminology sheet for explanation of abbreviations)

LOG OF BORING-DRAFT N:\GINT\PROJECTS\AX PROJECTS\2016\10072.GPJ BRAUN\_V8\_CURRENT.GDT 11/22/16 14:01

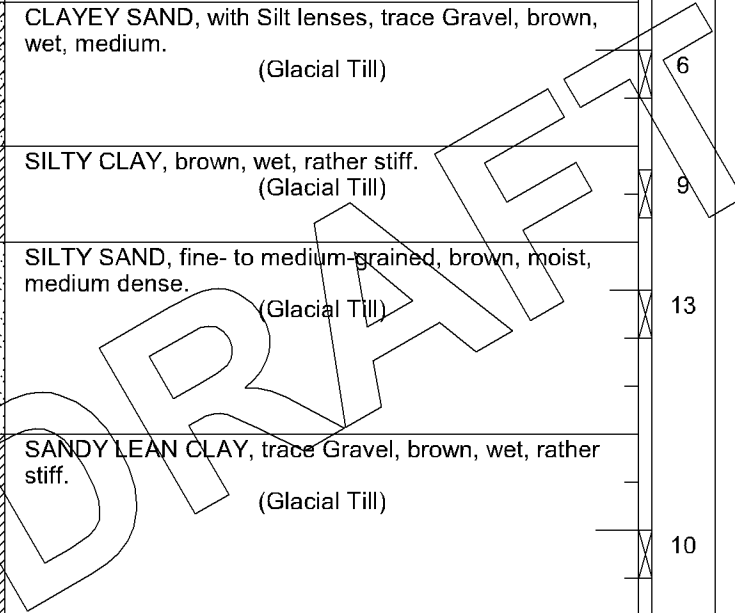

<b>Braun Project B1610072</b> <b>GEOTECHNICAL EVALUATION</b> <b>Friendship Village</b> <b>Highwood Drive and Townline Road</b> <b>Bloomington, Minnesota</b>	<b>BORING: ST-3 (cont.)</b>
	LOCATION: See attached sketch.

DRILLER: M. Belch	METHOD: 3 1/4" HSA, Autohammer	DATE: 10/25/16	SCALE: 1" = 4'
-------------------	--------------------------------	----------------	----------------

Elev. feet	Depth feet	ASTM Symbol	Description of Materials (ASTM D2488 or D2487)	BPF	WL	MC %	Tests or Notes
832.2	32.0		CLAYEY SAND, with Silt lenses, gray, wet, medium to rather stiff. (Glacial Till) (continued)				
				11			
823.2	41.0		END OF BORING.  Water not observed with 39 1/2 feet of hollow-stem auger in the ground.  Boring immediately backfilled with bentonite grout.	11			

(See Descriptive Terminology sheet for explanation of abbreviations)

LOG OF BORING-DRAFT N:\GINT\PROJECTS\AX PROJECTS\2016\10072.GPJ BRAUN\_V8\_CURRENT.GDT 11/22/16 14:01

DRAFT

<b>Braun Project B1610072</b> <b>GEOTECHNICAL EVALUATION</b> <b>Friendship Village</b> <b>Highwood Drive and Townline Road</b> <b>Bloomington, Minnesota</b>				BORING: <b>ST-4</b> LOCATION: See attached sketch.			
DRILLER: M. Takada		METHOD: 3 1/4" HSA, Autohammer		DATE: 10/25/16		SCALE: 1" = 4'	
Elev. feet	Depth feet	ASTM Symbol	Description of Materials (ASTM D2488 or D2487)	BPF	WL	MC %	Tests or Notes
870.8	0.0						
870.3	0.5	FILL	FILL: Clayey Sand, dark brown, moist. (Topsoil Fill)				
		SC	CLAYEY SAND, trace Gravel, brown, wet, rather soft. (Glacial Till)	4			
				4			
863.8	7.0	CL	SANDY LEAN CLAY, trace Gravel, brown, wet, rather stiff. (Glacial Till)	9		12	
861.8	9.0	SM	SILTY SAND, trace Gravel, brown, moist, medium dense. (Glacial Till)	18			
858.8	12.0	SC	CLAYEY SAND, trace Gravel, brown, wet, stiff. (Glacial Till)	14			
				13			
				15			
				13			
839.8	31.0			14			
			END OF BORING. **				

(See Descriptive Terminology sheet for explanation of abbreviations)

LOG OF BORING-DRAFT N:\GINT\PROJECTS\AX PROJECTS\2016\10072.GPJ BRAUN\_V8\_CURRENT.GDT 11/22/16 14:01

DRAFT

\*\* Water not observed with 29 1/2 feet of hollow-stem auger in the ground.  
  
 Boring immediately backfilled with bentonite grout.

<b>Braun Project B1610072</b> <b>GEOTECHNICAL EVALUATION</b> <b>Friendship Village</b> <b>Highwood Drive and Townline Road</b> <b>Bloomington, Minnesota</b>	<b>BORING: ST-5</b> LOCATION: See attached sketch.
--	---

DRILLER: M. Belch	METHOD: 3 1/4" HSA, Autohammer	DATE: 10/25/16	SCALE: 1" = 4'
-------------------	--------------------------------	----------------	----------------

Elev. feet	Depth feet	ASTM Symbol	Description of Materials (ASTM D2488 or D2487)	BPF	WL	MC %	Tests or Notes
869.8	0.0						
869.0	0.8	PAV FILL	4 inches of bituminous over 5 inches of aggregate base. FILL: Silty Sand, fine- to medium-grained, trace Gravel, with Clay seams, brown, moist.	5			
862.8	7.0	CL	LEAN CLAY, black, wet. (Buried Topsoil)	3		12	
857.8	12.0	CL	LEAN CLAY, with Sand lenses, brown, wet, rather soft. (Alluvium)	3		26	OC=3%
855.8	14.0	CL	LEAN CLAY, fine-grained, brown and gray, wet, rather soft to medium. (Glacial Till)	5		19	
				3		28	
841.8	28.0	SC	CLAYEY SAND, trace Gravel, gray, wet, medium to stiff. (Glacial Till)	8			
				10			

(See Descriptive Terminology sheet for explanation of abbreviations)

LOG OF BORING-DRAFT N:\GINT\PROJECTS\AX PROJECTS\2016\10072.GPJ BRAUN\_V8\_CURRENT.GDT 11/22/16 14:01

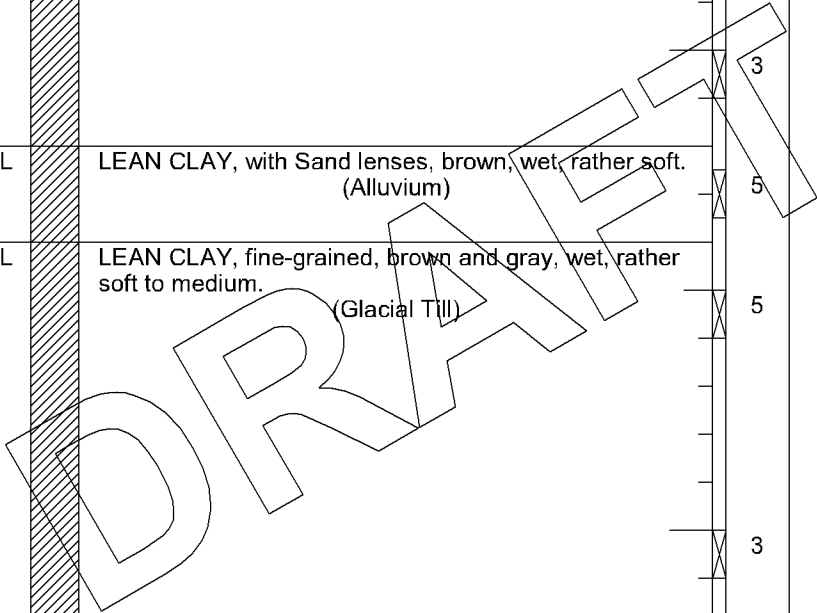

Braun Project B1610072 GEOTECHNICAL EVALUATION Friendship Village Highwood Drive and Townline Road Bloomington, Minnesota						BORING: <b>ST-5 (cont.)</b>	
DRILLER: M. Belch			METHOD: 3 1/4" HSA, Autohammer		DATE: <b>10/25/16</b>		SCALE: <b>1" = 4'</b>
Elev. feet	Depth feet	ASTM Symbol	Description of Materials (ASTM D2488 or D2487)	BPF	WL	MC %	Tests or Notes
837.8	32.0		CLAYEY SAND, trace Gravel, gray, wet, medium to stiff. (Glacial Till) (continued)	7		27	OC=1%
821.8	48.0	SM	SILTY SAND, fine-grained, gray, moist, medium dense. (Glacial Till)	10	▽		An open triangle in the water level (WL) column indicates the depth at which groundwater was observed while drilling. Groundwater levels fluctuate.
818.8	51.0		END OF BORING. Water observed at 40 feet while drilling. Boring immediately backfilled with bentonite grout.	15			
				20			

LOG OF BORING-DRAFT N:\GINT\PROJECTS\AX PROJECTS\2016\10072.GPJ BRAUN\_V8\_CURRENT.GDT 11/22/16 14:01

LOG OF BORING-DRAFT N:\GINT\PROJECTS\AX PROJECTS\2016\10072.GPJ BRAUN\_V8\_CURRENT.GDT 11/22/16 14:01

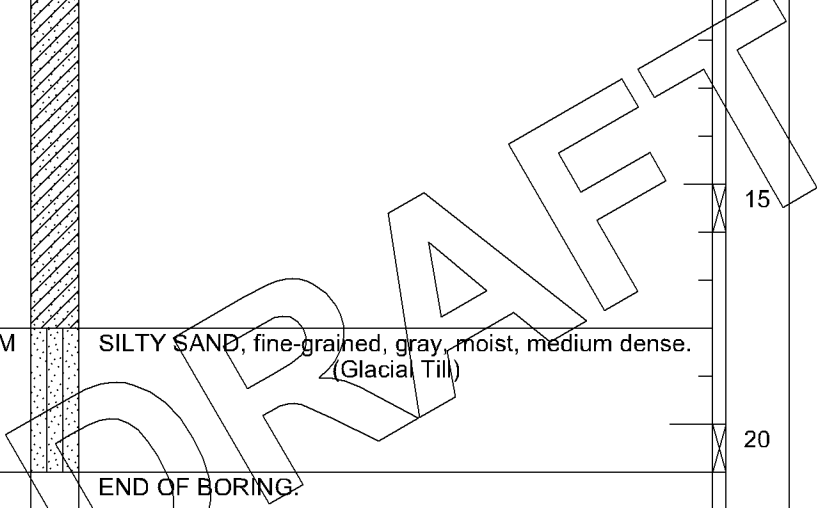

<b>Braun Project B1610072</b> <b>GEOTECHNICAL EVALUATION</b> <b>Friendship Village</b> <b>Highwood Drive and Townline Road</b> <b>Bloomington, Minnesota</b>	<b>BORING: ST-6</b>
	LOCATION: See attached sketch.

DRILLER: M. Takada	METHOD: 3 1/4" HSA, Autohammer	DATE: 10/25/16	SCALE: 1" = 4'
--------------------	--------------------------------	----------------	----------------

Elev. feet	Depth feet	ASTM Symbol	Description of Materials (ASTM D2488 or D2487)	BPF	WL	MC %	Tests or Notes
871.7	0.0	TS	SILTY SAND, dark brown, moist. (Topsoil)				
870.9	0.8	SC	CLAYEY SAND, brown, moist, rather stiff. (Glacial Till)	10			
867.7	4.0	SM	SILTY SAND, trace Gravel, brown, moist, loose to medium dense. (Glacial Till)	6			
			With Clay lenses below 13 feet.	9			
				18		3	P200=19%
				11			
				14			
				21			
				13			
843.7	28.0	CL	LEAN CLAY, gray, wet, rather stiff. (Glacial Till)	11			

(See Descriptive Terminology sheet for explanation of abbreviations)

LOG OF BORING-DRAFT N:\GINT\PROJECTS\AX PROJECTS\2016\10072.GPJ BRAUN\_V8\_CURRENT.GDT 11/22/16 14:01

DRAFT

<b>Braun Project B1610072</b> <b>GEOTECHNICAL EVALUATION</b> <b>Friendship Village</b> <b>Highwood Drive and Townline Road</b> <b>Bloomington, Minnesota</b>	<b>BORING: ST-6 (cont.)</b> LOCATION: See attached sketch.
--	---

DRILLER: M. Takada	METHOD: 3 1/4" HSA, Autohammer	DATE: 10/25/16	SCALE: 1" = 4'
--------------------	--------------------------------	----------------	----------------

Elev. feet	Depth feet	ASTM Symbol	Description of Materials (ASTM D2488 or D2487)	BPF	WL	MC %	Tests or Notes
839.7	32.0						
838.7	33.0						
		CL	SANDY LEAN CLAY, trace Gravel, gray, moist, very stiff. (Glacial Till)	24			
830.7	41.0			18			
			END OF BORING.  Water not observed with 39 1/2 feet of hollow-stem auger in the ground.  Boring immediately backfilled with bentonite grout.				

(See Descriptive Terminology sheet for explanation of abbreviations)

LOG OF BORING-DRAFT N:\GINT\PROJECTS\AX PROJECTS\2016\10072.GPJ BRAUN\_V8\_CURRENT.GDT 11/22/16 14:01

DRAFT

Braun Project B1610072 GEOTECHNICAL EVALUATION Friendship Village Highwood Drive and Townline Road Bloomington, Minnesota				BORING: <b>ST-7</b> LOCATION: See attached sketch.			
DRILLER: M. Takada		METHOD: 3 1/4" HSA, Autohammer		DATE: 10/28/16		SCALE: 1" = 4'	
Elev. feet	Depth feet	ASTM Symbol	Description of Materials (ASTM D2488 or D2487)	BPF	WL	MC %	Tests or Notes
871.1	0.0						
869.8	1.3	FILL	FILL: Lean Clay, dark brown, wet. (Topsoil Fill)				
		FILL	FILL: Poorly Graded Sand with Silt, fine-grained, brown, moist.	4			
867.1	4.0	FILL	FILL: Silty Sand, fine-grained, trace wood debris, dark brown, moist.	18			
864.1	7.0	SM	SILTY SAND, trace Gravel, brown, moist, loose to medium dense. (Glacial Till)	10			
				12		8	
				13			
				23			
853.1	18.0	ML	SILT, with Sand, brown, moist, medium dense. (Glacial Till)	19			
				15			
843.1	28.0	SC	CLAYEY SAND, trace Gravel, gray, moist, rather stiff. (Glacial Till)	10			
840.1	31.0		END OF BORING. **				

LOG OF BORING-DRAFT (See Descriptive Terminology sheet for explanation of abbreviations)

N:\GINT\PROJECTS\AX PROJECTS\2016\10072.GPJ BRAUN\_V8\_CURRENT.GDT 11/22/16 14:01

DRAFT

\*\* Water not observed with 29 1/2 feet of hollow-stem auger in the ground.  
Boring immediately backfilled.

Braun Project B1610072 GEOTECHNICAL EVALUATION Friendship Village Highwood Drive and Townline Road Bloomington, Minnesota				BORING: <b>ST-8</b> LOCATION: See attached sketch.			
DRILLER: M. Belch		METHOD: 3 1/4" HSA, Autohammer		DATE: 10/25/16		SCALE: 1" = 4'	
Elev. feet	Depth feet	ASTM Symbol	Description of Materials (ASTM D2488 or D2487)	BPF	WL	MC %	Tests or Notes
883.1	0.0						
882.3	0.8	FILL	FILL: Silty Sand, fine- to medium-grained, dark brown, moist. (Topsoil Fill)				
		FILL	FILL: Silty Sand, fine-grained, with Gravel, brown, moist.	26			
				15			
876.1	7.0	SM	SILTY SAND, fine- to medium-grained, trace Gravel, brown, moist, loose to medium dense. (Glacial Till)	15		7	
				8			
				12		7	
				17		4	P200=17%
				5			
860.1	23.0	SM	SILTY SAND, fine-grained, trace Gravel, brownish gray to gray, moist, loose. (Glacial Till)				
				9			** Water not observed while drilling. Water not observed to cave-in depth of 11 feet. Boring immediately backfilled.
852.1	31.0			10			
			END OF BORING. **				

LOG OF BORING-DRAFT N:\GINT\PROJECTS\AX PROJECTS\2016\10072.GPJ BRAUN\_V8\_CURRENT.GDT 11/22/16 14:01

LOG OF BORING-DRAFT N:\GINT\PROJECTS\AX PROJECTS\2016\10072.GPJ BRAUN\_V8\_CURRENT.GDT 11/22/16 14:01

DRAFT

<b>Braun Project B1610072</b> <b>GEOTECHNICAL EVALUATION</b> <b>Friendship Village</b> <b>Highwood Drive and Townline Road</b> <b>Bloomington, Minnesota</b>	<b>BORING: ST-9</b>
	LOCATION: See attached sketch.

DRILLER: M. Takada	METHOD: 3 1/4" HSA, Autohammer	DATE: 10/26/16	SCALE: 1" = 4'
--------------------	--------------------------------	----------------	----------------

Elev. feet	Depth feet	ASTM Symbol	Description of Materials (ASTM D2488 or D2487)	BPF	WL	MC %	Tests or Notes
858.2	0.0						
857.7	0.5	FILL SM	FILL: Organic Clay, black, wet. (Topsoil Fill)				
			SILTY SAND, fine- to medium-grained, trace Gravel, with Clay layers, brown, moist, loose to medium dense. (Glacial Till)	12			
				9			
				12			
849.2	9.0	ML	SILT, gray, wet, loose. (Glaciofluvium)	7			
				6		29	LL=28 PL=26 PI=2
844.2	14.0	SM	SILTY SAND, fine- to medium-grained, trace Gravel, brown to 28 feet then gray, moist, loose to medium dense. (Glacial Till)	10			
				20			
				21			
				19			

(See Descriptive Terminology sheet for explanation of abbreviations)

LOG OF BORING-DRAFT N:\GINT\PROJECTS\AX PROJECTS\2016\10072.GPJ BRAUN\_V8\_CURRENT.GDT 11/22/16 14:01

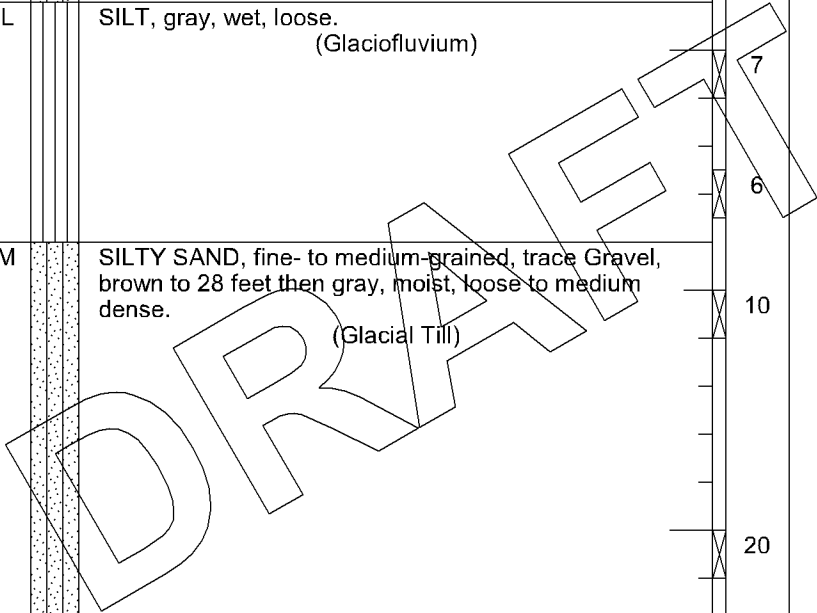

<b>Braun Project B1610072</b> <b>GEOTECHNICAL EVALUATION</b> <b>Friendship Village</b> <b>Highwood Drive and Townline Road</b> <b>Bloomington, Minnesota</b>	<b>BORING: ST-9 (cont.)</b>
	LOCATION: See attached sketch.

DRILLER: M. Takada	METHOD: 3 1/4" HSA, Autohammer	DATE: 10/26/16	SCALE: 1" = 4'
--------------------	--------------------------------	----------------	----------------

Elev. feet	Depth feet	ASTM Symbol	Description of Materials (ASTM D2488 or D2487)	BPF	WL	MC %	Tests or Notes
826.2	32.0		SILTY SAND, fine- to medium-grained, trace Gravel, brown to 28 feet then gray, moist, loose to medium dense.  (Glacial Till) (continued)				
				12			
817.2	41.0		END OF BORING.  Water not observed with 39 1/2 feet of hollow-stem auger in the ground.  Boring immediately backfilled with bentonite grout.	11			

(See Descriptive Terminology sheet for explanation of abbreviations)

LOG OF BORING-DRAFT N:\GINT\PROJECTS\AX PROJECTS\2016\10072.GPJ BRAUN\_V8\_CURRENT.GDT 11/22/16 14:01

DRAFT

<b>Braun Project B1610072</b> <b>GEOTECHNICAL EVALUATION</b> <b>Friendship Village</b> <b>Highwood Drive and Townline Road</b> <b>Bloomington, Minnesota</b>				<b>BORING: ST-10</b> LOCATION: See attached sketch.			
DRILLER: M. Takada		METHOD: 3 1/4" HSA, Autohammer		DATE: 10/25/16		SCALE: 1" = 4'	
Elev. feet	Depth feet	ASTM Symbol	Description of Materials (ASTM D2488 or D2487)	BPF	WL	MC %	Tests or Notes
863.2	0.0						
862.1	1.1	PAV	2 inches of bituminous over 11 inches of aggregate base.				
		FILL	FILL: Clayey Sand, trace Gravel, brown, moist.	12		10	
859.2	4.0	SM	SILTY SAND, fine- to medium-grained, trace Gravel, brown, moist, loose to medium dense. (Glacial Till)	13			
				10			
				20			
				13			
				12			
845.2	18.0	CL	LEAN CLAY, brown, wet, stiff. (Glacial Till)				
842.2	21.0		END OF BORING.	13			
			Water not observed with 19 1/2 feet of hollow-stem auger in the ground.				
			Boring immediately backfilled.				

(See Descriptive Terminology sheet for explanation of abbreviations)

LOG OF BORING-DRAFT N:\GINT\PROJECTS\AX PROJECTS\2016\10072.GPJ BRAUN\_V8\_CURRENT.GDT 11/22/16 14:00

DRAFT

<b>Braun Project B1610072</b> <b>GEOTECHNICAL EVALUATION</b> <b>Friendship Village</b> <b>Highwood Drive and Townline Road</b> <b>Bloomington, Minnesota</b>	<b>BORING: ST-11</b>
	LOCATION: See attached sketch.

DRILLER: B. Kammermeier	METHOD: 3 1/4" HSA, Autohammer	DATE: 10/27/16	SCALE: 1" = 4'
-------------------------	--------------------------------	----------------	----------------

Elev. feet	Depth feet	ASTM Symbol	Description of Materials (ASTM D2488 or D2487)	BPF	WL	MC %	Tests or Notes
860.3	0.0						
859.5	0.8	FILL	FILL: Organic Clay, with organics, roots and fibers, black, moist. (Topsoil Fill)				
		SM	SILTY SAND, fine- to medium-grained, trace Gravel, brown, moist, medium dense to loose. (Glacial Till)	13		12	
				10			
853.3	7.0	SP-SM	POORLY GRADED SAND with SILT, fine- to medium-grained, trace Gravel, brown, moist, loose to medium dense. (Glacial Outwash)	7		12	
				14			
848.3	12.0	SM	SILTY SAND, fine- to coarse-grained, trace Gravel, brown and reddish brown, moist, medium dense. (Glacial Outwash)	14		8	P200=9%
846.3	14.0	SC	CLAYEY SAND, trace Gravel, brown, wet, very stiff. (Glacial Till)	17			
842.3	18.0	SC	CLAYEY SAND, trace Gravel, gray, wet, stiff. (Glacial Till)				
839.3	21.0		END OF BORING.  Water not observed with 19 1/2 feet of hollow-stem auger in the ground.  Boring immediately backfilled.	13			

(See Descriptive Terminology sheet for explanation of abbreviations)

LOG OF BORING-DRAFT N:\GINT\PROJECTS\AX PROJECTS\2016\10072.GPJ BRAUN\_V8\_CURRENT.GDT 11/22/16 14:00

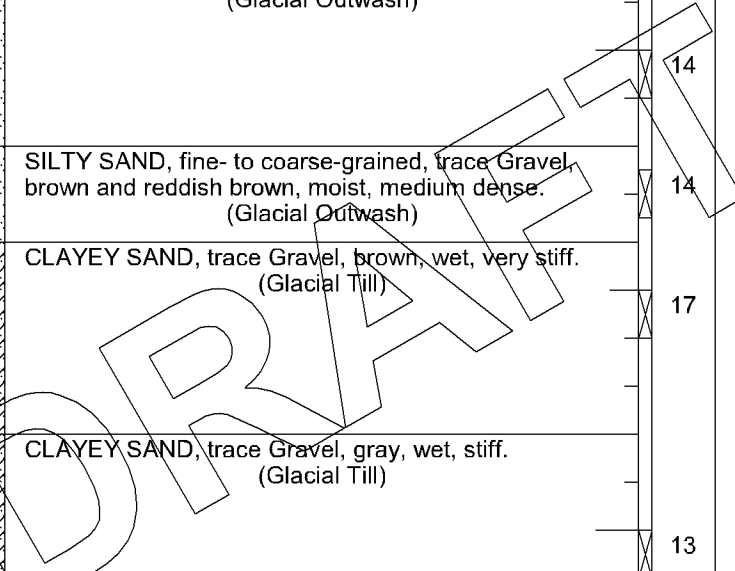

Braun Project B1610072 GEOTECHNICAL EVALUATION Friendship Village Highwood Drive and Townline Road Bloomington, Minnesota						BORING: <b>ST-12</b>			
DRILLER: B. Kammermeier						METHOD: 3 1/4" HSA, Autohammer		DATE: <b>10/27/16</b>	SCALE: <b>1" = 4'</b>
Elev. feet	Depth feet	ASTM Symbol	Description of Materials (ASTM D2488 or D2487)	BPF	WL	MC %	qp tsf	Tests or Notes	
858.9	0.0								
858.5	0.4	FILL	FILL: Organic Clay and Clayey Sand, black, moist. (Topsoil Fill)						
		SC	CLAYEY SAND, with Gravel, with Sand lenses, brown and gray, wet, rather stiff. (Glacial Till)	11		16			
854.9	4.0								
		SM	SILTY SAND, fine-grained, gray, moist, medium dense to loose. (Glacial Till)	15					
849.9	9.0			6		36		LL=32 PL=27 PI=5	
		SM	SILTY SAND, fine-grained, trace Gravel, gray, moist, medium dense to loose. (Glacial Till)	12					
844.9	14.0			10		27			
		ML	SILT, gray, wet, loose. (Glaciofluvium)	7					
840.9	18.0								
		SM	SILTY SAND, fine- to coarse-grained, with Gravel and Clay lenses, dark brown, moist, medium dense. (Glacial Till)	13	▽				
835.9	23.0								
		CL	SANDY LEAN CLAY, trace Gravel, gray, wet, rather stiff. (Glacial Till)	11			3 1/2	** Water observed at 20 feet while drilling.	
830.9	28.0							Boring immediately backfilled with bentonite grout.	
		SP-SM	POORLY GRADED SAND with SILT, fine- to medium-grained, trace Gravel, with Clay lenses, brown, waterbearing, medium dense. (Glacial Outwash)	30					
827.9	31.0								
			END OF BORING. **						

LOG OF BORING-DRAFT N:\GINT\PROJECTS\AX PROJECTS\2016\10072.GPJ BRAUN\_V8\_CURRENT.GDT 11/22/16 14:00

LOG OF BORING-DRAFT N:\GINT\PROJECTS\AX PROJECTS\2016\10072.GPJ BRAUN\_V8\_CURRENT.GDT 11/22/16 14:00

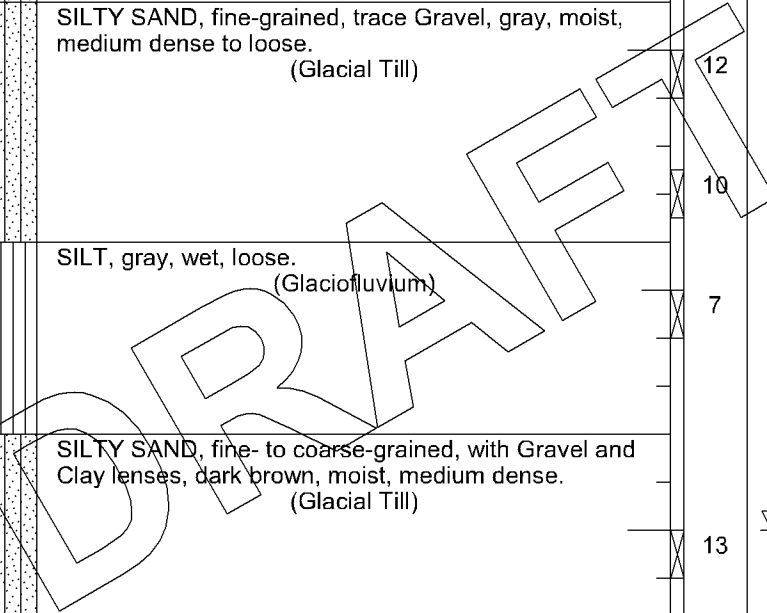

<b>Braun Project B1610072</b> <b>GEOTECHNICAL EVALUATION</b> <b>Friendship Village</b> <b>Highwood Drive and Townline Road</b> <b>Bloomington, Minnesota</b>	<b>BORING: ST-13</b>
	LOCATION: See attached sketch.

DRILLER: M. Takada	METHOD: 3 1/4" HSA, Autohammer	DATE: 10/28/16	SCALE: 1" = 4'
--------------------	--------------------------------	----------------	----------------

Elev. feet	Depth feet	ASTM Symbol	Description of Materials (ASTM D2488 or D2487)	BPF	WL	MC %	Tests or Notes
858.6	0.0						
858.2	0.4	FILL SM	FILL: Organic Clay, black, wet. (Topsoil Fill)				
			SILTY SAND, fine- to medium-grained, trace Gravel, brown, moist. (Glacial Till)	17			
854.6	4.0	SP-SM	POORLY GRADED SAND with SILT, brown, moist, medium dense. (Glacial Outwash)	12			
851.6	7.0	CL	SANDY LEAN CLAY, with Sand lenses, trace Gravel, brown, wet, very stiff. (Glacial Till)	19			
849.6	9.0	SM	SILTY SAND, fine- to medium-grained, trace Gravel, brown, moist, medium dense. (Glacial Till)	15		11	P200=38%
846.6	12.0	CL	SANDY LEAN CLAY, trace Gravel, brown, wet, medium to rather stiff. (Glacial Till)	6			
				10			
840.6	18.0	SC	CLAYEY SAND, trace Gravel, gray, wet, medium. (Glacial Till)				
837.6	21.0		END OF BORING.	8			
			Water not observed with 19 1/2 feet of hollow-stem auger in the ground.				
			Boring immediately backfilled.				

(See Descriptive Terminology sheet for explanation of abbreviations)

LOG OF BORING-DRAFT N:\GINT\PROJECTS\AX PROJECTS\2016\10072.GPJ BRAUN\_V8\_CURRENT.GDT 11/22/16 14:00

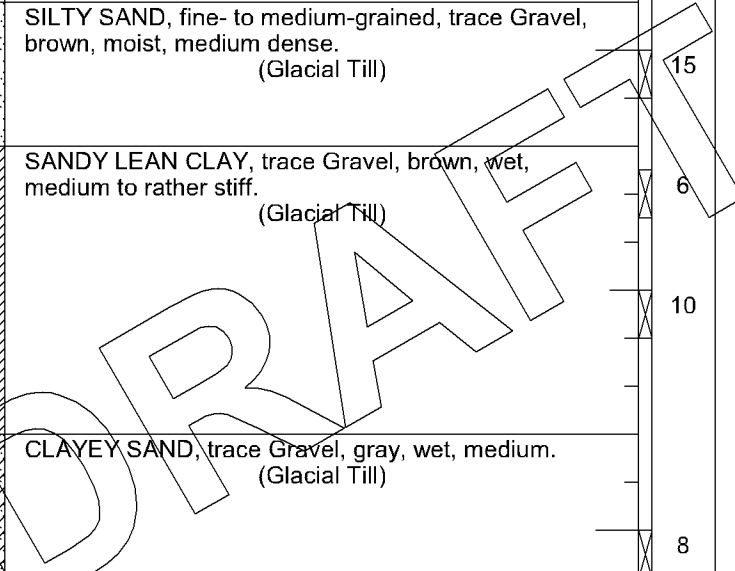

Braun Project B1610072 GEOTECHNICAL EVALUATION Friendship Village Highwood Drive and Townline Road Bloomington, Minnesota				BORING: <b>ST-14</b> LOCATION: See attached sketch.			
DRILLER: M. Takada		METHOD: 3 1/4" HSA, Autohammer		DATE: 10/27/16		SCALE: 1" = 4'	
Elev. feet	Depth feet	ASTM Symbol	Description of Materials (ASTM D2488 or D2487)	BPF	WL	MC %	Tests or Notes
858.7	0.0						
858.0	0.7	FILL	FILL: Organic Clay, trace roots and fibers, black, moist. (Topsoil Fill)				
		FILL	FILL: Silty Sand, fine- to medium-grained, trace Gravel, brown, moist.	10			
				12		11	
851.7	7.0						
		SP-SM	POORLY GRADED SAND with SILT, fine- to coarse-grained, with Gravel, brown, moist, medium dense. (Glacial Outwash)	25			
849.7	9.0						
		SM	SILTY SAND, fine- to coarse-grained, trace Gravel, brown, moist, loose. (Glacial Outwash)	8		8	P200=10%
847.7	11.0						
		SC	CLAYEY SAND, trace Gravel, brown and gray, wet, medium. (Glacial Till)	8			
844.7	14.0						
		CL	SANDY LEAN CLAY, trace Gravel, gray, wet, medium. (Glacial Till)	8		14	
				8			
835.7	23.0						
		SM	SILTY SAND, with Clay seams, gray, moist, medium dense. (Glacial Till)	15			** Water not observed while drilling. Boring immediately backfilled.
827.7	31.0			12			
			END OF BORING. **				

(See Descriptive Terminology sheet for explanation of abbreviations)

LOG OF BORING-DRAFT N:\GINT\PROJECTS\AX PROJECTS\2016\10072.GPJ BRAUN\_V8\_CURRENT.GDT 11/22/16 14:00

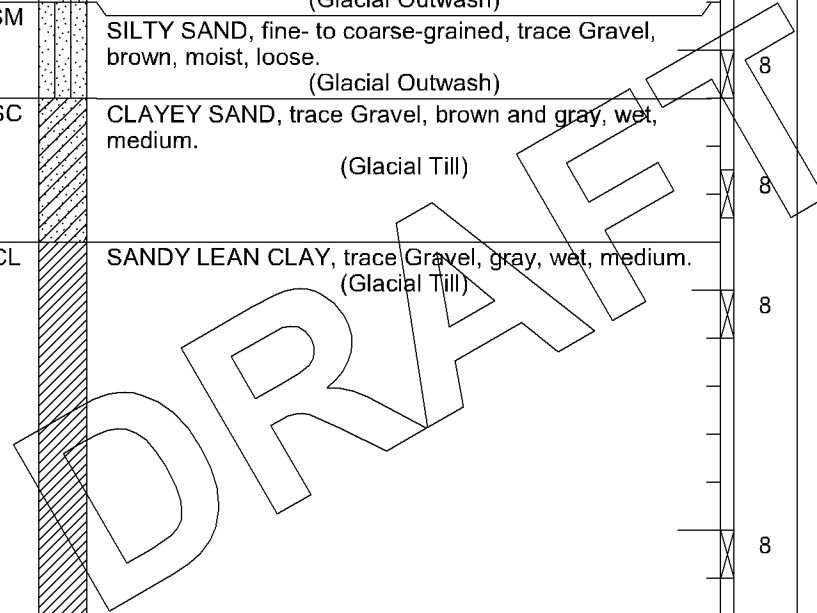

Braun Project B1610072 GEOTECHNICAL EVALUATION Friendship Village Highwood Drive and Townline Road Bloomington, Minnesota				BORING: <b>ST-15</b> LOCATION: See attached sketch.			
DRILLER: M. Takada		METHOD: 3 1/4" HSA, Autohammer		DATE: 10/26/16		SCALE: 1" = 4'	
Elev. feet	Depth feet	ASTM Symbol	Description of Materials (ASTM D2488 or D2487)	BPF	WL	MC %	Tests or Notes
857.8	0.5	FILL	FILL: Clayey Sand, black, moist. (Topsoil Fill)				
		SM	SILTY SAND, fine- to medium-grained, trace Gravel, brown, moist, loose to medium dense. (Glacial Till)	5		17	
				8			
				12			
				16			
846.3	12.0	SM	SILTY SAND, fine- to medium-grained, trace Gravel, Clay lenses, light brown, moist, medium dense. (Glacial Till)	12		12	
844.3	14.0	CL	SANDY LEAN CLAY, trace Gravel, gray, wet, stiff. (Glacial Till)	13			
840.3	18.0	ML	SANDY SILT, fine-grained, trace Gravel, brown, moist, loose. (Glacial Till)	8			
835.3	23.0	SP-SM	POORLY GRADED SAND with SILT, fine- to medium-grained, with Gravel, brown, waterbearing, medium dense. (Glacial Outwash)	12	▽		** Water observed at 24 feet while drilling.
830.3	28.0	SM	SILTY SAND, fine-grained, trace Gravel, gray, moist, loose. (Glacial Till)				Boring immediately backfilled with bentonite grout.
827.3	31.0		END OF BORING. **	10			

(See Descriptive Terminology sheet for explanation of abbreviations)

LOG OF BORING-DRAFT N:\GINT\PROJECTS\AX PROJECTS\2016\10072.GPJ BRAUN\_V8\_CURRENT.GDT 11/22/16 14:00

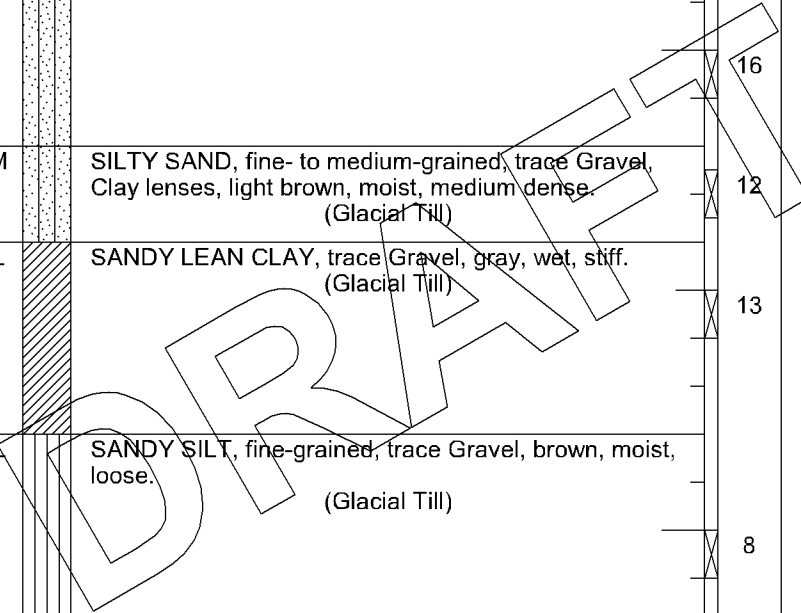

<b>Braun Project B1610072</b> <b>GEOTECHNICAL EVALUATION</b> <b>Friendship Village</b> <b>Highwood Drive and Townline Road</b> <b>Bloomington, Minnesota</b>				BORING: <b>ST-16</b> LOCATION: See attached sketch.			
DRILLER: M. Takada		METHOD: 3 1/4" HSA, Autohammer		DATE: 10/26/16		SCALE: 1" = 4'	
Elev. feet	Depth feet	ASTM Symbol	Description of Materials (ASTM D2488 or D2487)	BPF	WL	MC %	Tests or Notes
851.2	0.0						
850.4	0.8	FILL	FILL: Clayey Sand, black, moist. (Topsoil Fill)				
		FILL	FILL: Clayey Sand, trace Gravel, brown, wet.	6			
				14		10	
844.2	7.0	FILL	FILL: Sandy Lean Clay, trace Gravel, brown, wet.	6			
842.2	9.0	SM	SILTY SAND, fine- to medium-grained, trace Gravel, brown, wet, loose. (Glacial Till)	6			
839.2	12.0	SP-SM	POORLY GRADED SAND with SILT, fine- to medium-grained, trace Gravel, brown, waterbearing, loose to medium dense. (Glacial Outwash)	8			
				14			
830.2	21.0		END OF BORING.	8			
			Water observed at 12 1/2 feet while drilling.				
			Boring immediately backfilled.				

(See Descriptive Terminology sheet for explanation of abbreviations)

LOG OF BORING-DRAFT N:\GINT\PROJECTS\AX PROJECTS\2016\10072.GPJ BRAUN\_V8\_CURRENT.GDT 11/22/16 14:01

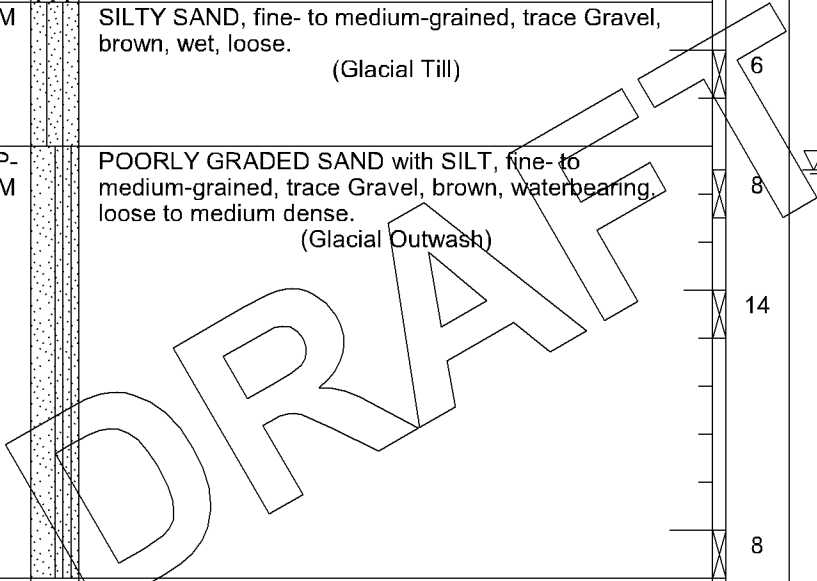

Braun Project B1610072 GEOTECHNICAL EVALUATION Friendship Village Highwood Drive and Townline Road Bloomington, Minnesota				BORING: <b>ST-17</b> LOCATION: See attached sketch.			
DRILLER: M. Belch		METHOD: 3 1/4" HSA, Autohammer		DATE: 11/16/16		SCALE: 1" = 4'	
Elev. feet	Depth feet	ASTM Symbol	Description of Materials (ASTM D2488 or D2487)	BPF	WL	MC %	Tests or Notes
850.7	0.0						
849.7	1.0	FILL	FILL: Organic Clay, trace roots and fibers, black, moist. (Topsoil Fill)				
		FILL	FILL: Silty Sand, fine- to coarse-grained, with Gravel, trace organics, brown, moist.	18		7	
846.7	4.0						
		SP-SM	POORLY GRADED SAND with SILT, fine- to medium-grained, with Gravel, brown, moist, very loose (Glacial Outwash)	4			
				4		10	
841.7	9.0						
		SM	SILTY SAND, fine- to medium-grained, with Gravel, brown and light brown, wet, loose to medium dense. (Glacial Outwash)	7			
				11			
836.7	14.0						
		CL	SANDY LEAN CLAY, trace Gravel, brown, wet, stiff. (Glacial Till)	13			
832.7	18.0						
		SM	SILTY SAND, fine-grained, trace Gravel, brown to gray, wet, medium dense. (Glacial Till)	15			
				15			** Water observed at 9 feet while drilling. Boring immediately backfilled.
				19			
819.7	31.0						
			END OF BORING. **				

LOG OF BORING-DRAFT N:\GINT\PROJECTS\AX PROJECTS\2016\10072.GPJ BRAUN\_V8\_CURRENT.GDT 11/22/16 14:01

LOG OF BORING-DRAFT N:\GINT\PROJECTS\AX PROJECTS\2016\10072.GPJ BRAUN\_V8\_CURRENT.GDT 11/22/16 14:01

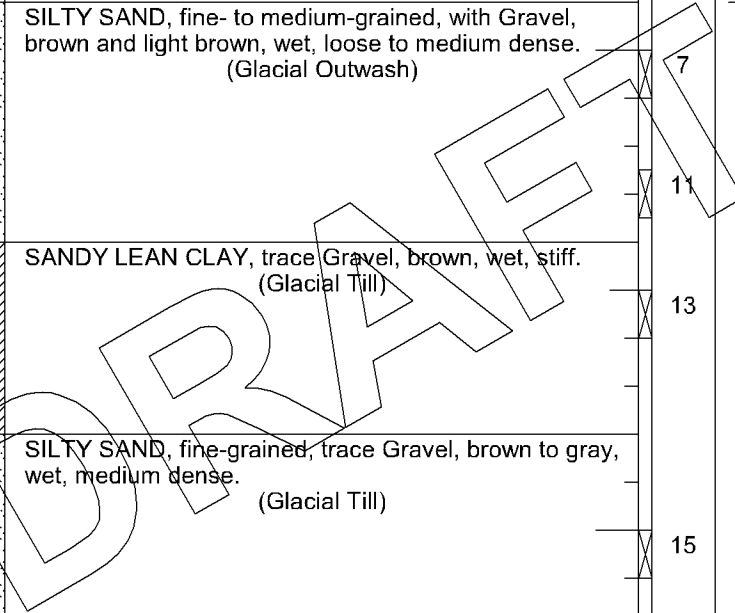

<b>Braun Project B1610072</b> <b>GEOTECHNICAL EVALUATION</b> <b>Friendship Village</b> <b>Highwood Drive and Townline Road</b> <b>Bloomington, Minnesota</b>				BORING: <b>ST-18</b> LOCATION: See attached sketch.			
DRILLER: M. Takada		METHOD: 3 1/4" HSA, Autohammer		DATE: <b>10/26/16</b>		SCALE: <b>1" = 4'</b>	
Elev. feet	Depth feet	ASTM Symbol	Description of Materials (ASTM D2488 or D2487)	BPF	WL	MC %	Tests or Notes
851.7	0.0	FILL	FILL: Clayey Sand, black, wet. (Topsoil Fill)				
849.7	2.0	FILL	FILL: Clayey Sand, brown, moist.	4		13	
847.7	4.0	CL	SANDY LEAN CLAY, brown, wet, medium. (Glacial Till)	7			
844.7	7.0	SM	SILTY SAND, fine- to medium-grained, trace Gravel, brown, wet, very loose to loose. (Glacial Till)	4	▽		
				4			
837.7	14.0	SP-SM	POORLY GRADED SAND with SILT, fine-grained, brown, waterbearing, loose. (Glacial Outwash)	5			
				6			
830.7	21.0		END OF BORING.	5			
			Water observed at 7 1/2 feet while drilling.				
			Boring immediately backfilled.				

(See Descriptive Terminology sheet for explanation of abbreviations)

LOG OF BORING-DRAFT N:\GINT\PROJECTS\AX PROJECTS\2016\10072.GPJ BRAUN\_V8\_CURRENT.GDT 11/22/16 14:01

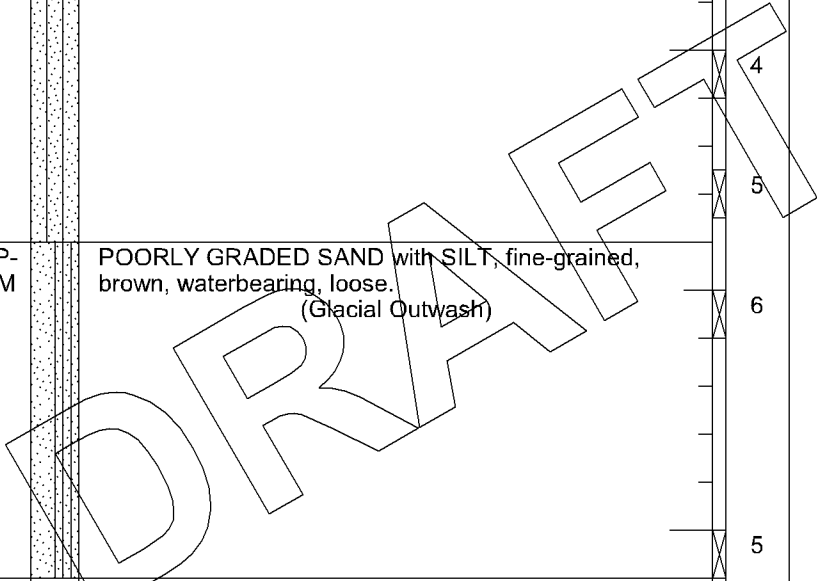



Braun Project B1610072 GEOTECHNICAL EVALUATION Friendship Village Highwood Drive and Townline Road Bloomington, Minnesota				BORING: <b>ST-20</b> LOCATION: See attached sketch.			
DRILLER: M. Takada		METHOD: 3 1/4" HSA, Autohammer		DATE: 10/26/16		SCALE: 1" = 4'	
Elev. feet	Depth feet	ASTM Symbol	Description of Materials (ASTM D2488 or D2487)	BPF	WL	MC %	Tests or Notes
871.5	0.0						
871.2	0.3	FILL	FILL: Organic Clay, black, moist. (Topsoil Fill)				
		FILL	FILL: Silty Sand, fine- to medium-grained, trace Gravel, dark brown, moist.	12			
				8			
864.5	7.0	SM	SILTY SAND, fine- to medium-grained, with Gravel, brown, moist, medium dense to loose. (Glacial Till)	12		11	
				9		9	
859.5	12.0	SP	POORLY GRADED SAND, fine- to medium-grained, trace Gravel, brown to reddish brown, wet to 15 feet then waterbearing, loose. (Glacial Outwash)	7			
				5	▽	22	P200=4%
853.5	18.0	CL	SANDY LEAN CLAY, trace Gravel, reddish brown, wet, very stiff. (Glacial Till)	24			
848.5	23.0	SP-SM	POORLY GRADED SAND with SILT, fine- to coarse-grained, trace Gravel, brown, waterbearing, loose. (Glacial Outwash)	7			** Water observed at 15 feet while drilling. Water observed at 16 feet with 30 feet of hollow-stem auger in the ground.
840.5	31.0			10			Boring immediately backfilled.
			END OF BORING. **				

(See Descriptive Terminology sheet for explanation of abbreviations)

LOG OF BORING-DRAFT N:\GINT\PROJECTS\AX PROJECTS\2016\10072.GPJ BRAUN\_V8\_CURRENT.GDT 11/22/16 14:01

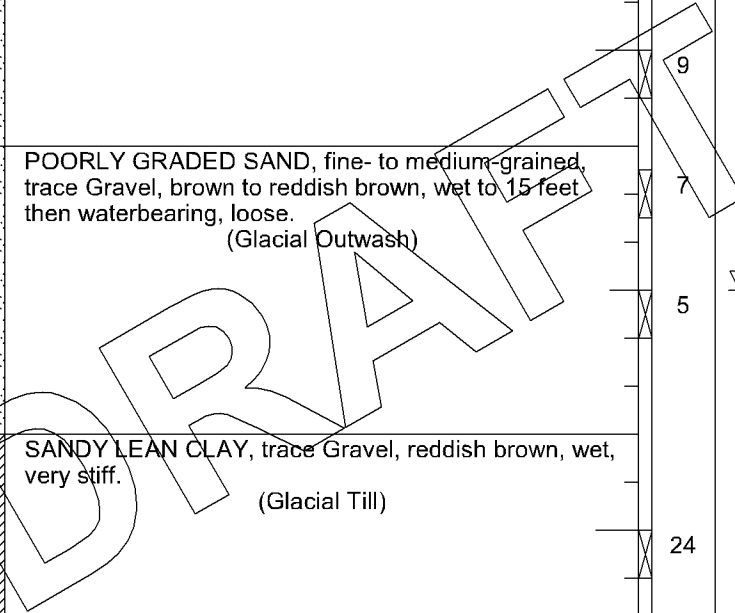

Braun Project B1610072 GEOTECHNICAL EVALUATION Friendship Village Highwood Drive and Townline Road Bloomington, Minnesota				BORING: <b>ST-21</b> LOCATION: See attached sketch.			
DRILLER: M. Takada		METHOD: 3 1/4" HSA, Autohammer		DATE: 10/28/16		SCALE: 1" = 4'	
Elev. feet	Depth feet	ASTM Symbol	Description of Materials (ASTM D2488 or D2487)	BPF	WL	MC %	Tests or Notes
856.8	0.0						
856.4	0.4	FILL SM	FILL: Organic Clay, black, wet. (Topsoil Fill) SILTY SAND, trace Gravel, brown, moist, loose. (Glacial Till)				
852.8	4.0	SC	CLAYEY SAND, brown, moist, rather soft. (Glacial Till)	6			
849.8	7.0	ML	SILT, grayish brown, wet, loose. (Glaciofluvium)	6		23	
847.8	9.0	CL	LEAN CLAY, with Sand, trace Gravel, brown, wet, rather stiff. (Glacial Till)	10			
844.8	12.0	SP-SM	POORLY GRADED SAND with SILT, fine- to coarse-grained, trace Gravel, brown, moist to wet, medium dense. (Glacial Outwash)	11			
				14			
				14*			* No sample recovery.
833.8	23.0	CL	SANDY LEAN CLAY, trace Gravel, gray, wet, rather stiff to medium. (Glacial Till)	11			** Water not observed with 29 1/2 feet of hollow-stem auger in the ground. Boring immediately backfilled with bentonite grout.
825.8	31.0		END OF BORING. **	8			

(See Descriptive Terminology sheet for explanation of abbreviations)

LOG OF BORING-DRAFT N:\GINT\PROJECTS\AX PROJECTS\2016\10072.GPJ BRAUN\_V8\_CURRENT.GDT 11/22/16 14:01

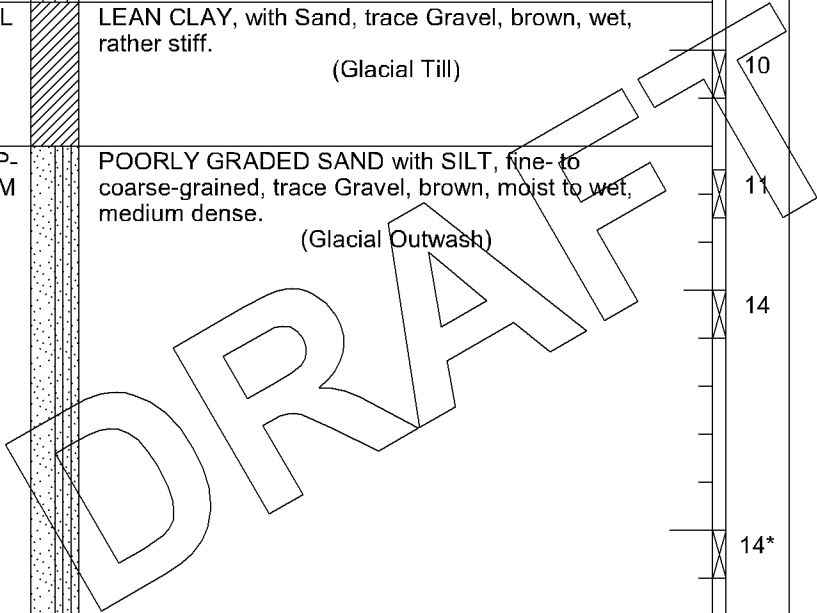

<b>Braun Project B1610072</b> <b>GEOTECHNICAL EVALUATION</b> <b>Friendship Village</b> <b>Highwood Drive and Townline Road</b> <b>Bloomington, Minnesota</b>				<b>BORING: ST-22</b> LOCATION: See attached sketch.			
DRILLER: M. Takada		METHOD: 3 1/4" HSA, Autohammer		DATE: 10/25/16		SCALE: 1" = 4'	
Elev. feet	Depth feet	ASTM Symbol	Description of Materials (ASTM D2488 or D2487)	BPF	WL	MC %	Tests or Notes
873.9	0.0						
873.1	0.8	FILL	FILL: Sandy Lean Clay, with Gravel, dark brown, wet. (Topsoil Fill)				
		FILL	FILL: Sandy Lean Clay, trace Gravel, brown, wet.				
869.9	4.0			3		14	
		CL	SANDY LEAN CLAY, trace Gravel, brown, moist to wet, medium to very stiff. (Glacial Till)	6			
				9			
				10		13	
				22			
				16			
855.9	18.0	SM	SILTY SAND, trace Gravel, brown to 28 feet then gray, moist, medium dense. (Glacial Till)	20			
				26			
842.9	31.0			14			
			END OF BORING. **				

(See Descriptive Terminology sheet for explanation of abbreviations)

LOG OF BORING-DRAFT N:\GINT\PROJECTS\AX PROJECTS\2016\10072.GPJ BRAUN\_V8\_CURRENT.GDT 11/22/16 14:01

DRAFT

\*\* Water not observed with 29 1/2 feet of hollow-stem auger in the ground.  
  
 Boring immediately backfilled with bentonite grout.



Criteria for Assigning Group Symbols and Group Names Using Laboratory Tests <sup>a</sup>				Soils Classification	
				Group Symbol	Group Name <sup>b</sup>
Coarse-grained Soils more than 50% retained on No. 200 sieve	Gravels More than 50% of coarse fraction retained on No. 4 sieve	Clean Gravels Less than 5% fines <sup>e</sup>	$C_u \geq 4$ and $1 \leq C_c \leq 3$ <sup>c</sup>	GW	Well-graded gravel <sup>d</sup>
		Gravels with Fines More than 12% fines <sup>e</sup>	Fines classify as ML or MH	GM	Silty gravel <sup>d f g</sup>
			Fines classify as CL or CH	GC	Clayey gravel <sup>d f g</sup>
		Sands 50% or more of coarse fraction passes No. 4 sieve	Clean Sands Less than 5% fines <sup>i</sup>	$C_u \geq 6$ and $1 \leq C_c \leq 3$ <sup>c</sup>	SW
	Sands with Fines More than 12% <sup>i</sup>		Fines classify as ML or MH	SM	Silty sand <sup>f g h</sup>
			Fines classify as CL or CH	SC	Clayey sand <sup>f g h</sup>
	Fine-grained Soils 50% or more passed the No. 200 sieve		Silt and Clays Liquid limit less than 50	Inorganic PI > 7 and plots on or above "A" line <sup>j</sup>	CL
		Inorganic PI < 4 or plots below "A" line <sup>j</sup>		ML	Silt <sup>k l m</sup>
Organic		Liquid limit - oven dried < 0.75	OL	Organic clay <sup>k l m n</sup>	
		Liquid limit - not dried < 0.75	OL	Organic silt <sup>k l m o</sup>	
Silt and clays Liquid limit 50 or more		Inorganic PI plots on or above "A" line	CH	Fat clay <sup>k l m</sup>	
		Inorganic PI plots below "A" line	MH	Elastic silt <sup>k l m</sup>	
		Organic	Liquid limit - oven dried < 0.75	OH	Organic clay <sup>k l m p</sup>
			Liquid limit - not dried < 0.75	OH	Organic silt <sup>k l m q</sup>
Highly Organic Soils		Primarily organic matter, dark in color and organic odor		PT	Peat

- Based on the material passing the 3-inch (75mm) sieve.
- If field sample contained cobbles or boulders, or both, add "with cobbles or boulders or both" to group name.
- $C_u = D_{60}/D_{10}$   $C_c = (D_{30})^2 / (D_{10} \times D_{60})$
- If soil contains  $\geq 15\%$  sand, add "with sand" to group name.
- Gravels with 5 to 12% fines require dual symbols:  
GW-GM well-graded gravel with silt  
GW-GC well-graded gravel with clay  
GP-GM poorly graded gravel with silt  
GP-GC poorly graded gravel with clay
- If fines classify as CL-ML, use dual symbol GC-GM or SC-SM.
- If fines are organic, add "with organic fines" to group name.
- If soil contains  $\geq 15\%$  gravel, add "with gravel" to group name.
- Sand with 5 to 12% fines require dual symbols:  
SW-SM well-graded sand with silt  
SW-SC well-graded sand with clay  
SP-SM poorly graded sand with silt  
SP-SC poorly graded sand with clay
- If Atterberg limits plot in hatched area, soil is a CL-ML, silty clay.
- If soil contains 10 to 29% plus No. 200, add "with sand" or "with gravel" whichever is predominant.
- If soil contains  $\geq 30\%$  plus No. 200, predominantly sand, add "sandy" to group name.
- If soil contains  $\geq 30\%$  plus No. 200, predominantly gravel, add "gravelly" to group name.
- PI  $\geq 4$  and plots on or above "A" line.
- PI < 4 or plots below "A" line.
- PI plots on or above "A" lines.
- PI plots below "A" line.

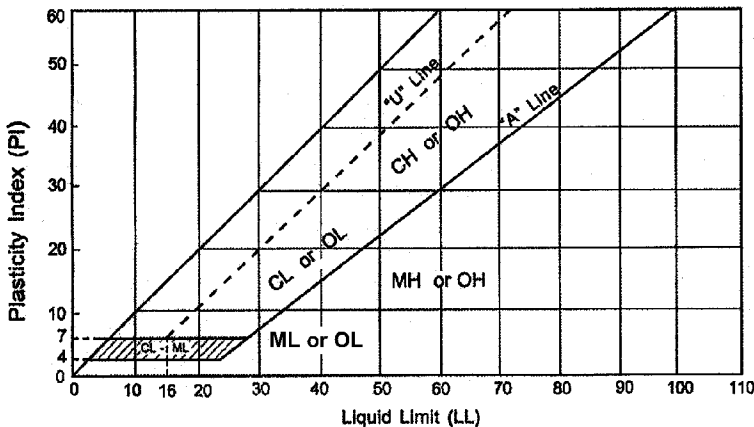

**Laboratory Tests**

DD	Dry density, pcf	OC	Organic content, %
WD	Wet density, pcf	S	Percent of saturation, %
MC	Natural moisture content, %	SG	Specific gravity
LL	Liquid limit, %	C	Cohesion, psf
PL	Plastic limits, %	$\phi$	Angle of internal friction
PI	Plasticity index, %	qu	Unconfined compressive strength, psf
P200	% passing 200 sieve	qp	Pocket penetrometer strength, tsf

**Particle Size Identification**

Boulders.....	over 12"
Cobbles .....	3" to 12"
Gravel	
Coarse .....	3/4" to 3"
Fine.....	No. 4 to 3/4"
Sand	
Coarse .....	No. 4 to No. 10
Medium .....	No. 10 to No. 40
Fine.....	No. 40 to No. 200
Silt .....	<No. 200, PI < 4 or below "A" line
Clay .....	<No. 200, PI $\geq 4$ and on or about "A" line

**Relative Density of Cohesionless Soils**

Very Loose.....	0 to 4 BPF
Loose.....	5 to 10 BPF
Medium dense .....	11 to 30 BPF
Dense .....	31 to 50 BPF
Very dense.....	over 50 BPF

**Consistency of Cohesive Soils**

Very soft.....	0 to 1 BPF
Soft .....	2 to 3 BPF
Rather soft .....	4 to 5 BPF
Medium .....	6 to 8 BPF
Rather stiff .....	9 to 12 BPF
Stiff .....	13 to 16 BPF
Very stiff.....	17 to 30 BPF
Hard.....	over 30 BPF

**Drilling Notes**

Standard penetration test borings were advanced by 3 1/4" or 6 1/4" ID hollow-stem augers, unless noted otherwise. Jetting water was used to clean out auger prior to sampling only where indicated on logs. All samples were taken with the standard 2" OD split-tube samples, except where noted.

Power auger borings were advanced by 4" or 6" diameter continuous flight, solid-stem augers. Soil classifications and strata depths were inferred from disturbed samples augered to the surface, and are therefore, somewhat approximate.

Hand auger borings were advanced manually with a 1 1/2" or 3 1/4" diameter auger and were limited to the depth from which the auger could be manually withdrawn.

**BPF:** Numbers indicate blows per foot recorded in standard penetration test, also known as "N" value. The sampler was set 6" into undisturbed soil below the hollow-stem auger. Driving resistances were then counted for second and third 6" increments, and added to get BPF. Where they differed significantly, they are reported in the following form: 2/12 for the second and third 6" increments, respectively.

**WH:** WH indicates the sampler penetrated soil under weight of hammer and rods alone; driving not required.

**WR:** WR indicates the sampler penetrated soil under weight of rods alone; hammer weight, and driving not required.

**TW:** TW indicates thin-walled (undisturbed) tube sample.

**Note:** All tests were run in general accordance with applicable ASTM standards.