



## **STRUCTURAL REPORT V.2**

### **Structural Analysis CPC059-STRL1 Structural-Building / Rooftop attachment (3 unique rooftop sectors)**

**MIN Killebrew C-Band  
2051 Killebrew Drive  
Bloomington, MN 55425**

October 26, 2021

Herzog Engineering Project No. 211426

Prepared for:

Design 1  
9973 Valley View Road  
Eden Prairie, MN 55344



October 26, 2021

Design 1  
Attention: Sam Diedrich  
9973 Valley View Road  
Eden Prairie, MN 55344

Re: MIN Killebrew C-Band  
Structural Analysis V.2  
CPC059-STRL1 Structural - Building / Rooftop attachment (3 unique rooftop sectors)  
2051 Killebrew Drive  
Bloomington, MN 55425  
Project Number: 211426

Dear Mr. Diedrich:

At your request, I have analyzed the structural capacity of the existing equipment mounts and host building framing to support the proposed equipment changes. The proposed equipment to be supported is shown in Table 1 of this report.

In summary, the building and existing mounts for all sectors have been analyzed and have been found to have **SUFFICIENT CAPACITY** to support the proposed equipment. The design stress ratios with regards to maximum design capacity are shown in Table 2.

Per TIA-222-H, all bolted connections, including u-bolts, shall be provided with nut-locking device or mechanism such as, but not limited to, lock nuts, lock washers, or palnuts, to prevent loosening.

This structural analysis has been performed in accordance with the local code requirements listed in this report and the disclaimers noted within.

If you have any questions, please don't hesitate to contact me at (612) 844-1234.

Sincerely,  
**Herzog Engineering, LLC**

Marissa Wildeck, E.I.T.  
Structural Engineer

Thomas Mach, P.E.  
Structural Engineer

I hereby certify that this plan, specification, or report was prepared by me or under my direct supervision and that I am a duly Licensed Professional Engineer under the laws of the State of Minnesota.	
Print Name:	<u>Thomas L. Mach</u>
Signature	
Date	<u>10-26-2021</u> LICENSE # <u>1000000000</u>

### A. SCOPE OF WORK SUMMARY

The intent of this structural analysis is to complete a feasibility structural analysis per the TIA-222-H standard, for the antenna mounts with the proposed equipment loading.

### B. BASIS OF DESIGN

Reference codes, standards, and construction documents:

- 1.) ANSI/TIA-222-H, dated 2017, Structural Standard for Antenna Supporting Structures, Antennas and Small Wind Turbine Support Structures.
- 2.) 2020 Minnesota State Building Code (IBC 2018).
- 3.) AISC 360-16, Specification for Structural Steel Buildings
- 4.) Design 1 / MIN Killebrew C-Band / Project No. 20212249150 / Rev. 0 drawings / dated 10-26-21.
- 5.) Design 1 / MIN Killebrew OPTM / Project No. 20192005316 / Rev. A drawings / dated 09-18-19 / RevA\_MINC\_Killebrew\_OPTM\_09-18-19.
- 6.) Design 1 / MIN Killebrew LTE ADD PCS 850 / Project No. 20161456568 / Pre-Rev. B drawings / PRELIM. REV. B\_MIN\_Killebrew Option 1\_850PCS.
- 7.) Design 1 / MIN Killebrew / Project No. 03066300134 / As-Built drawings / dated 09-21-04 / MIN\_Killebrew AsBuilt.
- 8.) Herzog Engineering, LLC. / MIN Killebrew OPTM / Project No. 191271 / Structural Review V. 2 / dated 10-17-19.
- 9.) Herzog Engineering, LLC. / MIN Killebrew LTE ADD PCS 850 / Project No. 161156 / Rev. 0 drawings / dated 02-22-17.

### C. APPURTENANCES AND EQUIPMENT

Proposed Antenna / Equipment – Table 1:

<b>Table 1 - Existing and Proposed Antenna / Equipment</b>							
<b>Equipment Owner</b>	<b>Centerline Elevation AGL (ft.)</b>	<b>Type</b>	<b>Position</b>	<b>Qty.</b>	<b>Manuf.</b>	<b>Model</b>	<b>Status</b>
X Sector - Shelter							
Verizon	77.0	Antenna	1	1	Commscope	NHH-45C-R2B	Existing to Remain
Verizon	77.0	Antenna	2	1	Commscope	NHH-45C-R2B	Existing to Remain
Verizon	79.0	RRU	(See Note 2)	1	Ericsson	RRU32 B66A	Existing to Remain
Verizon	75.8	RRU		1	Ericsson	RRU32 B2	Existing to Remain

C. APPURTENANCES AND EQUIPMENT (CONT.)

<b>Table 1 - Existing and Proposed Antenna / Equipment (CONT.)</b>							
<b>Equipment Owner</b>	<b>Centerline Elevation AGL (ft.)</b>	<b>Type</b>	<b>Position</b>	<b>Qty.</b>	<b>Manuf.</b>	<b>Model</b>	<b>Status</b>
<b>X Sector – Shelter (CONT.)</b>							
Verizon	77.0	Antenna	3	1	Ericsson	KRE 101 2251/2	Existing to Remain
Verizon	74.0	RRU	(See Note 3)	1	Ericsson	4449 RRU	Existing to Remain
Verizon	75.8	RRU	(See Note 2)	1	Raycap	3315 Dist. Box	Existing to Remain
Verizon	77.0	Antenna	4	1	JMA	X7CQAP-86-865-VR4	Existing to Remain
Verizon	79.7	Antenna	5 (See Note 3)	1	Ericsson	AIR 6449	New
<b>Y Sector – Rooftop Sled</b>							
Verizon	68.0	Antenna	1	1	Commscope	NHH-45B-R2B	Existing to Remain
Verizon	68.0	Antenna	2	1	Commscope	NHH-45B-R2B	Existing to Remain
Verizon	68.0	RRU	(See Note 2)	1	Ericsson	RRU32 B66A	Existing to Remain
Verizon	64.8	RRU		1	Ericsson	RRU32 B2	Existing to be Relocated
Verizon	68.0	Antenna	3	1	Ericsson	KRE 101 2251/2	Existing to Remain
Verizon	65.5	RRU		1	Ericsson	4449 RRU	Existing to Remain
Verizon	73.0	RRU	(See Note 2)	1	Raycap	3315 Dist. Box	Existing to Remain
Verizon	77.0	Antenna	4 (See Note 4)	1	JMA	X7CQAP-86-865-VR4	Existing to Remain
Verizon	68.0	Antenna	5	1	Ericsson	AIR 6449	New
<b>Z Sector – Screen Wall</b>							
Verizon	77.0	Antenna	1	1	Commscope	NHH-65C-R2B	Existing to Remain
Verizon	77.0	Antenna	2	1	Commscope	NHH-65C-R2B	Existing to Remain
Verizon	77.0	RRU	(See Note 2)	1	Ericsson	RRU32 B66A	Existing to Remain
Verizon	73.8	RRU		1	Ericsson	RRU32 B2	Existing to Remain

C. APPURTENANCES AND EQUIPMENT (CONT.)

<b>Table 1 - Existing and Proposed Antenna / Equipment (CONT.)</b>							
<b>Equipment Owner</b>	<b>Centerline Elevation AGL (ft.)</b>	<b>Type</b>	<b>Position</b>	<b>Qty.</b>	<b>Manuf.</b>	<b>Model</b>	<b>Status</b>
Z Sector – Screen Wall (CONT.)							
Verizon	77.0	Antenna	3 (See Note 3)	1	Ericsson	KRE 101 2251/2	Existing to Remain
Verizon	74.3	RRU		1	Ericsson	4449 RRU	Existing to Remain
Verizon	74.8	RRU	(See Note 2)	1	Raycap	3315 Dist. Box	Existing to Remain
Verizon	77.0	Antenna	4	1	JMA	X7CQAP-86-865-VR4	Existing to Remain
Verizon	79.7	Antenna	5 (See Note 3)	1	Ericsson	AIR 6449	New

Table 1 Notes:

- 1.) All equipment elevations are estimated, see Section B document (4).
- 2.) Equipment is mounted separately from antenna positions, see Section B document (4).
- 3.) Position 3 and 5 antennas are mounted on the same pipe, see Section B documents (4).
- 4.) Y Sector position 4 antenna mounted separately from sector, see Section B documents (4).

D. RESULTS SUMMARY

Mount Member Analysis Results – Table 2:

<b>Table 2 – Mount Member Design Check</b>				
<b>Mount Member</b>	<b>Member Type</b>	<b>Max. Design Utilization</b>	<b>Pass / Fail</b>	<b>Remarks</b>
X Sector - Shelter				
Frame	Mounting Pipes	8.4%	Pass	2.5"Ø Nominal Sch. 40
Frame	Support HSS	0.7%	Pass	HSS6x4x1/4
Frame	Bracket plate	22.5%	Pass	1/4" Plate 6"x6"
Unistrut	Horizontals	30.0%	Pass	P1000 WT
Y Sector – Rooftop Sled				
Frame	Mounting Pipes	33.1%	Pass	2.5"Ø Nominal Sch. 40
Frame	Base channel	25.8%	Pass	C8x11.5
Frame	Brace channel	6.3%	Pass	C6x13
Frame	HSS Post	15.0%	Pass	HSS3x3x1/4
Frame	HSS Beam	22.3%	Pass	HSS3x3x1/4

#### D. RESULTS SUMMARY (CONT.)

<b>Table 2 – Mount Member Design Check (CONT.)</b>				
<b>Mount Member</b>	<b>Member Type</b>	<b>Max. Design Utilization</b>	<b>Pass / Fail</b>	<b>Remarks</b>
Z Sector – Screen Wall				
Frame	Mounting Pipes	31.7%	Pass	2.0"Ø Nominal Sch. 40
Frame	Post	93.7%	Pass	W4x13
Frame	Base Beam	50.9%	Pass	W4x13
Frame	Z Brackets	20.4%	Pass	L3x3x1/4 brackets

#### Table 2 Notes:

- 1.) See Appendix 1 for supporting structural calculations.

#### EQUIPMENT ROOM DISCUSSION

The proposed DC UP-Converter Equipment has negligible weight increase. Other equipment in the equipment room is to remain. The existing host building is adequate to support this equipment update.

#### E. REPORT DISCLAIMERS AND ASSUMPTIONS

- 1.) This report and analysis was performed under the assumption that all information provided to Herzog Engineering, LLC is current and correct. This includes but is not limited to site data, mapping reports, existing and proposed appurtenances, tower and foundation details, and geotechnical data. If this information is not current and correct, this report should be considered obsolete and further analysis will be required.
- 2.) This analysis assumes that the structural components and mounts, including all steel sections and attachment hardware are in good working order and in their original state, free from rust or other forms of corrosion.
- 3.) Capacity of the structural members is based on the member sizes and configuration supplied. The material grade is as per the data supplied or as assumed and stated.
- 4.) All connections (bolted and welded) are assumed to develop the member capacity unless stated otherwise in this report.
- 5.) Ring clamps and other clamp connections are excluded from this report and analysis unless noted otherwise in the report.
- 6.) This structural analysis and report by Herzog Engineering, LLC reviews only the main structural components of the mount. Unless noted otherwise, sub-elements such as bolts, welds, plate connections, etc. have been excluded from this analysis and report.



F. APPENDIX 1 – STRUCTURAL CALCULATIONS

- 1.) Load Determination
- 2.) RISA-3D Frame Analysis – X Sector
- 3.) RISA-3D Frame Analysis – Y Sector
- 4.) RISA-3D Frame Analysis – Z Sector



**Wind Load**

Bloomington

Wind Load Design Criteria

TIA-222-H / Standard Reference

$z =$	<b>80.00</b>	<b>feet</b>	(Height above ground)
$V =$	<b>109</b>	<b>MPH</b>	(Basic wind speed without ice, ASCE 7-16 Hazard Tool)
Exposure Category =	<b>C</b>		(A.2.6.5, and 2.6.5.1.2)
Risk Category =	<b>II</b>		(A.2.2 and Table 2-1)
$K_d =$	<b>0.95</b>		(Table 2-2, also $K_d=0.95$ for all mounts per 16.6)
$Z_n =$	<b>900</b>		(Table 2-4)
$\alpha =$	<b>9.50</b>		(Table 2-4)
$K_{zmin} =$	<b>0.85</b>		(Table 2-4)
$K_c =$	<b>1.00</b>		(Table 2-4)
$2.01(z/z_g)^{2/\alpha} =$	<b>1.21</b>		(2.6.5.2)
$K_z =$	<b>1.21</b>		(2.6.5.2)
$K_{zt} =$	<b>1.00</b>		(2.6.6.2 Topographic Factor)
$G_h =$	<b>1.00</b>		(2.6.11.2 and 2.6.11, for appurtenance mounting systems $G_h=1.0$ per 16.6)

Does the building meet the requirements of 1 or 2 under section 2.6.7? (Y or N) N

$z_p =$	<b>0.00</b>		(Parapet height)
$z_r =$	<b>0.00</b>		(Height above roof)
$X_b =$	<b>0.00</b>		(Horiz. distance from windward face to center of structure)
$W_s =$	<b>0.00</b>		(Width of the windward face of the building)
$H_s =$	<b>0.00</b>		(Height of the windward face of the building)
$H_1 =$	<b>0.00</b>		
$H_2 =$	<b>0.00</b>		
Is $H_1 < z_r <= H_2$ ?	<b>YES</b>		
$W_s/H_s$	<b>#DIV/0!</b>		
$K_s =$	<b>1.00</b>		(2.6.7 and Fig. 2-2)
$K_a =$	<b>0.90</b>		(2.6.11.2-for Mounting systems, $K_a=0.90$ per 16.6)
$K_e =$	<b>1.00</b>		(2.6.8)
$q_z =$	<b>34.89</b>	<b>psf</b>	(2.6.11.6 Velocity Pressure)
$C_{d(flat)} =$	<b>2.00</b>		(Table 2-9)
$C_{d(round)} =$	<b>1.20</b>		(Table 2-9)



**Wind Load (Continued)**

**Wind Loads**

Any Flat Surface	62.80 psf			
Angles	Leg (in.)	A <sub>A</sub>	EPA <sub>A</sub>	F <sub>A(wind)</sub> (lb/ft)
L1/2x1/2	0.50	0.04	0.08	2.62
L3/4x3/4	0.75	0.06	0.11	3.93
L1x1	1	0.08	0.15	5.23
L1.25x1.25	1.25	0.10	0.19	6.54
L1.5x1.5	1.5	0.13	0.23	7.85
L1.75x1.75	1.75	0.15	0.26	9.16
L2x2	2	0.17	0.30	10.47
L2.5x2.5	2.5	0.21	0.38	13.08
L3x3	3	0.25	0.45	15.70
L3.5x3.5	3.5	0.29	0.53	18.32
L4x4	4	0.33	0.60	20.93
L4.5x4.5	4.5	0.38	0.68	23.55
L5x5	5	0.42	0.75	26.17
L5.5x5.5	5.5	0.46	0.83	28.79
L6x6	6	0.50	0.90	31.40
L8x8	8	0.67	1.20	41.87
PL1/4x6	6	0.50	0.90	31.40
HSS6x4	4	0.33	0.60	20.93
Unistrut	1.625	0.14	0.24	8.50

**Pipe Rounds**

	OD (in.)	A <sub>A</sub>	EPA <sub>A</sub>	F <sub>A(wind)</sub> (lb/ft)
3/4" Solid Rod	0.75	0.06	0.07	2.36
1" Solid Rod	1.00	0.08	0.09	3.14
1 1/4" Solid Rod	1.25	0.10	0.11	3.93
Pipe 0.75 Std.	1.05	0.09	0.09	3.30
Pipe 1 Std.	1.32	0.11	0.12	4.15
Pipe 1 1/4 Std.	1.66	0.14	0.15	5.21
Pipe 1 1/2 Std.	1.9	0.16	0.17	5.97
Pipe 2 Std.	2.38	0.20	0.21	7.47
Pipe 2 1/2 Std.	2.88	0.24	0.26	9.04
Pipe 3 Std.	3.5	0.29	0.32	10.99
Pipe 3 1/2 Std.	4	0.33	0.36	12.56
Pipe 4 Std.	4.5	0.38	0.41	14.13
Pipe 5 Std.	5.56	0.46	0.50	17.46
Pipe 6 Std.	6.63	0.55	0.60	20.82
Pipe 8 Std.	8.63	0.72	0.78	27.10
Pipe 10 Std.	10.8	0.90	0.97	33.91

**Equipment**

	Width (in.)	Length (in.)	Height (in.)	A <sub>A</sub> (sq. ft.)	C <sub>A</sub>	EPA <sub>A</sub> (sq. ft.)	F <sub>A(wind)</sub> (lbs.)	Weight (lbs.)	Aspect Ratio
<b>NORMAL</b>									
AIR6449 Antenna	15.9	10.6	30.6	3.4	1.2	3.6	127.3	96.8	1.9
NHH-45C-R2B Antenna	18.0	7.0	95.9	12.0	1.3	14.3	499.0	87.1	5.3
NHH-45B-R2B Antenna	18.0	7.0	72.0	9.0	1.3	10.3	358.0	73.6	4.0
NHH-65C-R2B Antenna	11.9	7.1	96.0	7.9	1.4	10.3	357.6	51.6	8.1
KRE 101 2251 Antenna	7.9	4.7	17.7	1.0	1.2	1.0	36.5	33.0	2.2
X7CQAP-86-865-VR4 Antenna	14.6	7.3	96.0	9.7	1.4	12.1	422.1	71.8	6.6
RRUS32	12.1	7.0	27.2	2.3	1.2	2.5	86.1	52.9	2.2
4449	13.2	9.4	18.0	1.7	1.2	1.8	62.2	70.0	1.4
3315 Dist. Box	15.7	10.3	25.7	2.8	1.2	3.0	105.6	26.9	1.6
<b>TRANSVERSE</b>									
AIR6449 Antenna	10.6	15.9	30.6	2.3	1.2	2.5	86.1		2.9
NHH-45C-R2B Antenna	7.0	18.0	95.9	4.7	1.6	6.8	237.6		13.7
NHH-45B-R2B Antenna	7.0	18.0	72.0	3.5	1.5	4.8	165.9		10.3
NHH-65C-R2B Antenna	7.1	11.9	96.0	4.7	1.6	6.9	240.4		13.5
KRE 101 2251 Antenna	4.7	7.9	17.7	0.6	1.3	0.7	22.8		3.8
X7CQAP-86-865-VR4 Antenna	7.3	14.6	96.0	4.9	1.6	7.0	245.3		13.2
RRUS32	7.0	12.1	27.2	1.3	1.3	1.5	52.4		3.9
4449	9.4	13.2	18.0	1.2	1.2	1.3	44.3		1.9



**Structure**

**Wind Load**

Bloomington

**Wind Load Design Criteria**

**TIA-222-H / Standard Reference**

z =	80.00	feet	(Height above ground)
V =	109.00	MPH	(Basic wind speed without ice, ASCE 7-16 Hazard Tool)
Exposure Category =	C		(A.2.6.5, and 2.6.5.1.2)
Risk Category =	II		(A.2.2 and Table 2-1)
K <sub>d</sub> =	0.85		(Table 2-2, also K <sub>d</sub> =0.85 For Bldg. walls)
Z <sub>g</sub> =	900.00		(Table 2-4)
α =	9.50		(Table 2-4)
K <sub>zmin</sub> =	0.85		(Table 2-4)
K <sub>c</sub> =	1.00		(Table 2-4)
2.01(z/z <sub>g</sub> ) <sup>2/α</sup> =	1.21		(2.6.5.2)
K <sub>z</sub> =	1.21		(2.6.5.2)
K <sub>zt</sub> =	1.00		(2.6.6.2 Topographic Factor)
G <sub>n</sub> =	0.85		(2.6.9.1)
Does the building meet the requirements of 1 or 2 under section 2.6.7? (Y or N)			N
z <sub>p</sub> =	0.00		(Parapet height)
z <sub>r</sub> =	0.00		(Height above roof)
X <sub>0</sub> =	0.00		(Horiz. distance from windward face to center of structure)
W <sub>s</sub> =	0.00		(Width of the windward face of the building)
H <sub>s</sub> =	0.00		(Height of the windward face of the building)
H <sub>1</sub> =	0.00		
H <sub>2</sub> =	0.00		
Is H <sub>1</sub> <= z <sub>r</sub> <= H <sub>2</sub> ?	YES		
W <sub>s</sub> /H <sub>s</sub>	#DIV/0!		
K <sub>s</sub> =	1.00		(2.6.7 and Fig. 2-2)
K <sub>a</sub> =	0.90		(2.6.11.2-for Mounting systems, K <sub>a</sub> =0.90 per 16.6)
K <sub>e</sub> =	1.00		(2.6.8)
q <sub>z</sub> =	31.22	psf	(2.6.11.6 Velocity Pressure)
A <sub>f</sub>	319.00	sf	
A <sub>r</sub>	0.00	sf	
A <sub>g</sub>	319.00	sf	
Solidity Ratio	1.00		
Square or Triangular?	Square		
C <sub>f</sub> (square)	2.10		Square Cross Sections
C <sub>f</sub> (triangular)	0.00		Triangular Cross Section

Fst = 55.73 psf Ultimate  
 Fst = 33.44 psf ASD



**Ice Load**

Bloomington

**Ice Load Design Criteria**

**TIA-222-H / Standard Reference**

z =	<b>80.00</b>	<b>feet</b>	(Height above ground)
t <sub>i</sub> =	<b>1.50</b>	<b>inches</b>	(Design ice thickness for site location - Fig. B-9, ASCE 7-16 Hazard Tool)
Risk Category =	II		
l <sub>ice</sub> =	<b>1.00</b>		(Table 2-3)
K <sub>iz</sub> =	<b>1.09</b>		(2.6.10 Height Escalation Factor)
K <sub>zt</sub> =	<b>1.00</b>		(2.6.6.2 Topographic Factor)
t <sub>iz</sub> =	<b>1.64</b>	<b>inches</b>	(Design ice thickness for site location, 2.6.10)
γ <sub>ice</sub> =	<b>56.00</b>	<b>lb/ft<sup>3</sup></b>	(2.6.10 Unit weight of ice)

**Ice Loads**

**Angles**

		<b>D<sub>c</sub></b>	<b>A<sub>iz</sub></b>	<b>w<sub>ice</sub> (lb/ft)</b>
Unistrut	<b>1.63</b>	2.30	20.27	7.88
PL1/4x6	<b>0.25</b>	6.01	39.36	15.31
HSS3X3	<b>3.00</b>	4.24	30.28	11.78
C8X11.5	<b>8.00</b>	8.32	51.30	19.95
C6X13	<b>6.00</b>	6.39	41.34	16.08
L1x1	<b>1</b>	1.41	15.72	6.11
L1.25x1.25	<b>1.25</b>	1.77	17.54	6.82
L1.5x1.5	<b>1.5</b>	2.12	19.36	7.53
L1.75x1.75	<b>1.75</b>	2.47	21.18	8.24
L2x2	<b>2</b>	2.83	23.00	8.94
L2.5x2.5	<b>2.5</b>	3.54	26.64	10.36
L3x2	<b>3</b>	3.61	27.00	10.50
L3x3	<b>3</b>	4.24	30.28	11.78
L3.5x3.5	<b>3.5</b>	4.95	33.92	13.19
L4x3	<b>4</b>	5.00	34.18	13.29
L4.5x4.5	<b>4.5</b>	6.36	41.20	16.02
L5x5	<b>5</b>	7.07	44.85	17.44
L5.5x5.5	<b>5.5</b>	7.78	48.49	18.86
L6x6	<b>6</b>	8.49	52.13	20.27
L7x7	<b>7</b>	9.90	59.41	23.10
L7.5x7.5	<b>7.5</b>	10.61	63.05	24.52
L11x11	<b>11</b>	15.56	88.53	34.43

**Pipe Rounds**

		<b>D<sub>c</sub></b>	<b>A<sub>iz</sub></b>	<b>w<sub>ice</sub> (lb/ft)</b>
3/4" Solid Rod	<b>0.75</b>	0.75	12.30	4.78
1" Solid Rod	<b>1.00</b>	1.00	13.59	5.28
1 1/4" Solid Rod	<b>1.25</b>	1.25	14.87	5.78
Pipe 0.75 Std.	<b>1.05</b>	1.05	13.84	5.38
Pipe 1 Std.	<b>1.32</b>	1.32	15.23	5.92
Pipe 1 1/4 Std.	<b>1.66</b>	1.66	16.99	6.61
Pipe 1 1/2 Std.	<b>1.9</b>	1.90	18.22	7.09
Pipe 2 Std.	<b>2.38</b>	2.38	20.69	8.05
Pipe 2 1/2 Std.	<b>2.88</b>	2.88	23.27	9.05
Pipe 3 Std.	<b>3.5</b>	3.50	26.46	10.29
Pipe 3 1/2 Std.	<b>4</b>	4.00	29.03	11.29
Pipe 4 Std.	<b>4.5</b>	4.50	31.61	12.29
Pipe 5 Std.	<b>5.56</b>	5.56	37.07	14.41
Pipe 6 Std.	<b>6.63</b>	6.63	42.57	16.56
Pipe 8 Std.	<b>8.63</b>	8.63	52.87	20.56
Pipe 10 Std.	<b>10.8</b>	10.80	64.04	24.91

**Ice Load (Continued)**

<u>Equipment</u>	<u>Width (in.)</u>	<u>Length (in.)</u>	<u>Height (in.)</u>	<u>D<sub>c</sub> (in.)</u>	<u>A<sub>iz</sub> (sq. in.)</u>	<u>w<sub>ice</sub> (lb/ft)</u>	<u>W<sub>ice</sub> (lbs.)</u>
AIR6449 Antenna	15.9	10.6	30.6	19.1	106.8	41.5	105.9
NHH-45C-R2B Antenna	18.0	7.0	95.9	19.3	107.9	42.0	335.3
NHH-45B-R2B Antenna	18.0	7.0	72.0	19.3	107.9	42.0	251.7
NHH-65C-R2B Antenna	11.9	7.1	96.0	13.9	79.8	31.0	248.2
KRE 101 2251 Antenna	7.9	4.7	17.7	9.2	55.7	21.7	31.9
X7CQAP-86-865-VR4 Antenna	14.6	7.3	96.0	16.3	92.5	36.0	287.7
RRUS32	12.1	7.0	27.2	14.0	80.4	31.3	70.9



**Wind Load on Ice**                      Bloomington

**Wind Load on Ice Design Criteria**

**TIA-222-H / Standard Reference**

$z =$	<b>80.00</b>	<b>feet</b>	(Height above ground)
$V_i =$	<b>50</b>	<b>MPH</b>	(Basic wind speed with ice, Fig. B-9)
$t_{iz} =$	<b>1.64</b>	<b>inches</b>	(Design ice thickness for site location, 2.6.10)
$K_g =$	<b>0.95</b>		(Table 2-2, also $K_d=0.95$ for all mounts per 16.6)
$K_z =$	<b>1.21</b>		(2.6.5.2)
$K_{zt} =$	<b>1.00</b>		(2.6.6.2 Topographic Factor)
$G_h =$	<b>1.00</b>		(2.6.11.2 and 2.6.11, for appurtenance mounting systems $G_h=1.0$ per 16.6)
$K_s =$	<b>1.00</b>		(2.6.7 and Fig. 2-2)
$K_d =$	<b>0.90</b>		(2.6.11.2-for Mounting systems, $K_a=0.90$ per 16.6)
$K_e =$	<b>1.00</b>		(2.6.8)
$q_{zice} =$	<b>7.34</b>	<b>psf</b>	(2.6.9.6 Velocity Pressure with ice)
$C_{a(flat)} =$	<b>2.00</b>		(Table 2-9)
$C_{a(round)} =$	<b>1.20</b>		(Table 2-9)

**Wind Loads on Ice**  
**Any Flat Surface**

**Angles**

	<b>Leg (in.)</b>	<b><math>A_A</math></b>	<b><math>EPA_A</math></b>	<b><math>F_{A(windonice)}</math> (lb/ft)</b>
L1/4x1/4	0.25	0.29	0.32	2.33
L1/2x1/2	0.50	0.31	0.34	2.50
L3/4x3/4	0.75	0.34	0.36	2.66
L1x1	1	0.36	0.38	2.83
L1.25x1.25	1.25	0.38	0.41	2.99
L1.5x1.5	1.5	0.40	0.43	3.16
L1.75x1.75	1.75	0.42	0.45	3.32
L2x2	2	0.44	0.47	3.49
L2.5x2.5	2.50	0.48	0.52	3.82
L3x3	3	0.52	0.56	4.15
L3.5x3.5	3.5	0.56	0.61	4.48
L4x4	4	0.61	0.65	4.81
L4.5x4.5	4.5	0.65	0.70	5.14
L5x5	5	0.69	0.74	5.47
L5.5x5.5	5.5	0.73	0.79	5.80
L6x6	6	0.77	0.83	6.13
L8x8	8	0.94	1.01	7.45
PL1/4	0.25	0.29	0.32	2.33
PL1/4x6	6	0.77	0.83	6.13
HSS6x4	4	0.61	0.65	4.81
Unistrut	1.625	0.41	0.44	3.24



**Wind Load on Ice (Continued)**

**Wind Loads on Ice**

**Pipe Rounds**

	OD (in.)	A <sub>Ice</sub>	EPA <sub>AIce</sub>	F <sub>A(windonice)</sub> (lb/ft)
3/4" Solid Rod	0.75	0.34	0.36	2.66
1" Solid Rod	1.00	0.36	0.38	2.83
1 1/4" Solid Rod	1.25	0.38	0.41	2.99
Pipe 0.75 Std.	1.05	0.36	0.39	2.86
Pipe 1 Std.	1.32	0.38	0.41	3.04
Pipe 1 1/4 Std.	1.66	0.41	0.44	3.26
Pipe 1 1/2 Std.	1.9	0.43	0.47	3.42
Pipe 2 Std.	2.38	0.47	0.51	3.74
Pipe 2 1/2 Std.	2.88	0.51	0.55	4.07
Pipe 3 Std.	3.5	0.56	0.61	4.48
Pipe 3 1/2 Std.	4	0.61	0.65	4.81
Pipe 4 Std.	4.5	0.65	0.70	5.14
Pipe 5 Std.	5.56	0.74	0.80	5.84
Pipe 6 Std.	6.63	0.83	0.89	6.55
Pipe 8 Std.	8.63	0.99	1.07	7.87
Pipe 10 Std.	10.8	1.17	1.27	9.30

**Equipment**

	Width (in.)	Length (in.)	Height (in.)	A <sub>z</sub> (sq. in.)	Eff. Dia w/ Ice (in.)	EPA <sub>AIce</sub> (sq. ft.)	F <sub>A(windonice)</sub> (lbs.)
<b>NORMAL</b>							
AIR6449 Antenna	15.9	10.6	30.6	106.8	22.4	5.1	37.7
NHH-45C-R2B Antenna	18.0	7.0	95.9	107.9	22.6	16.2	119.3
NHH-45B-R2B Antenna	18.0	7.0	72.0	107.9	22.6	12.2	89.6
NHH-65C-R2B Antenna	11.9	7.1	96.0	79.8	17.1	12.3	90.6
KRE 101 2251 Antenna	7.9	4.7	17.7	55.7	12.5	1.7	12.1
X7CQAP-86-865-VR4 Antenna	14.6	7.3	96.0	92.5	19.6	14.1	103.6
RRUS32	12.1	7.0	27.2	80.4	17.3	3.5	25.8
4449	13.2	9.4	18.0	91.9	19.5	2.6	19.3

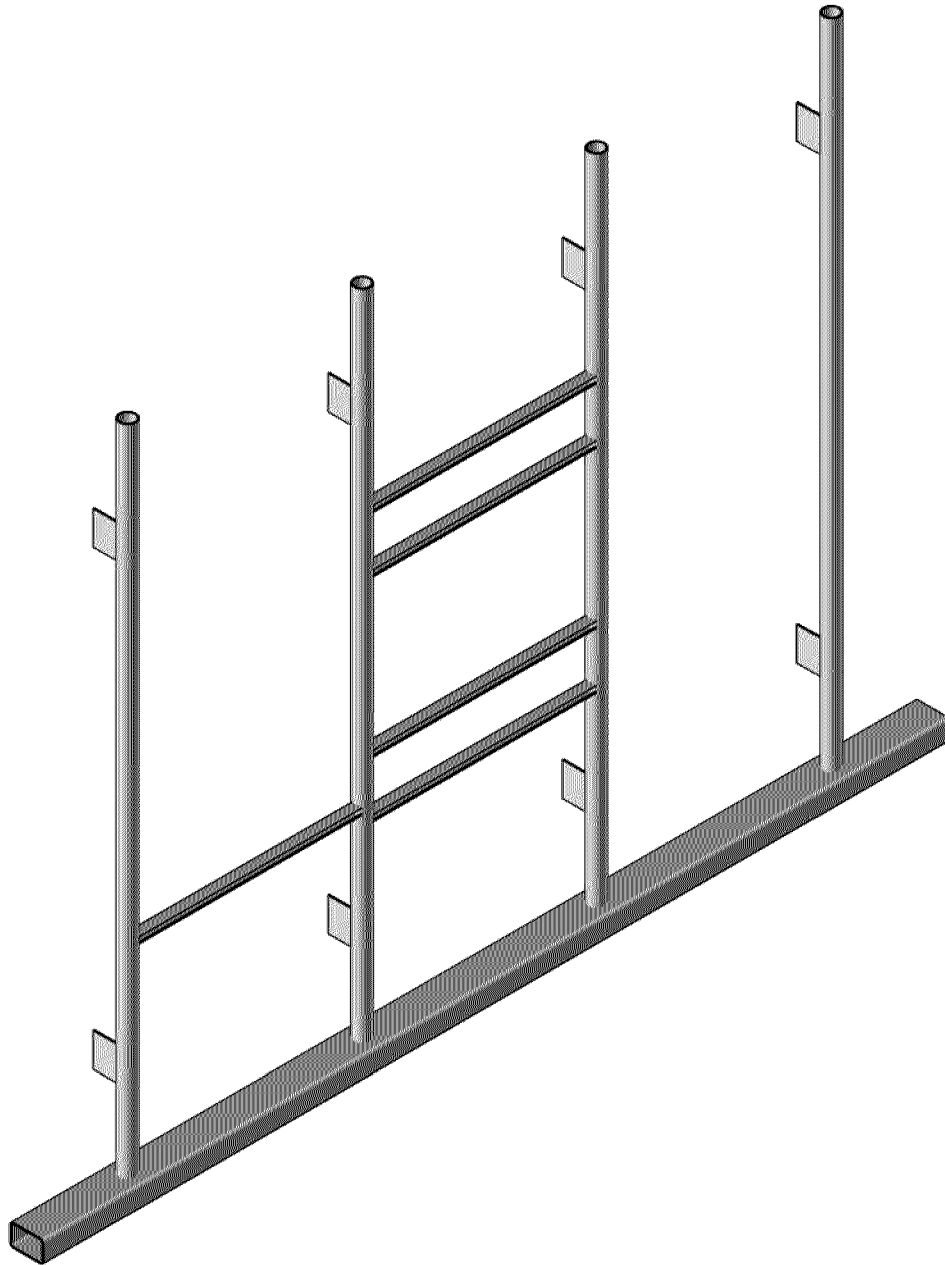
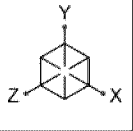

Envelope Only Solution

Herzog Engineering, LLC.

JJC

211426

MIN Killebrew - X Sector

3D VIEW - 1

Sep 17, 2021

211426 MIN Killebrew X Sector.r3d

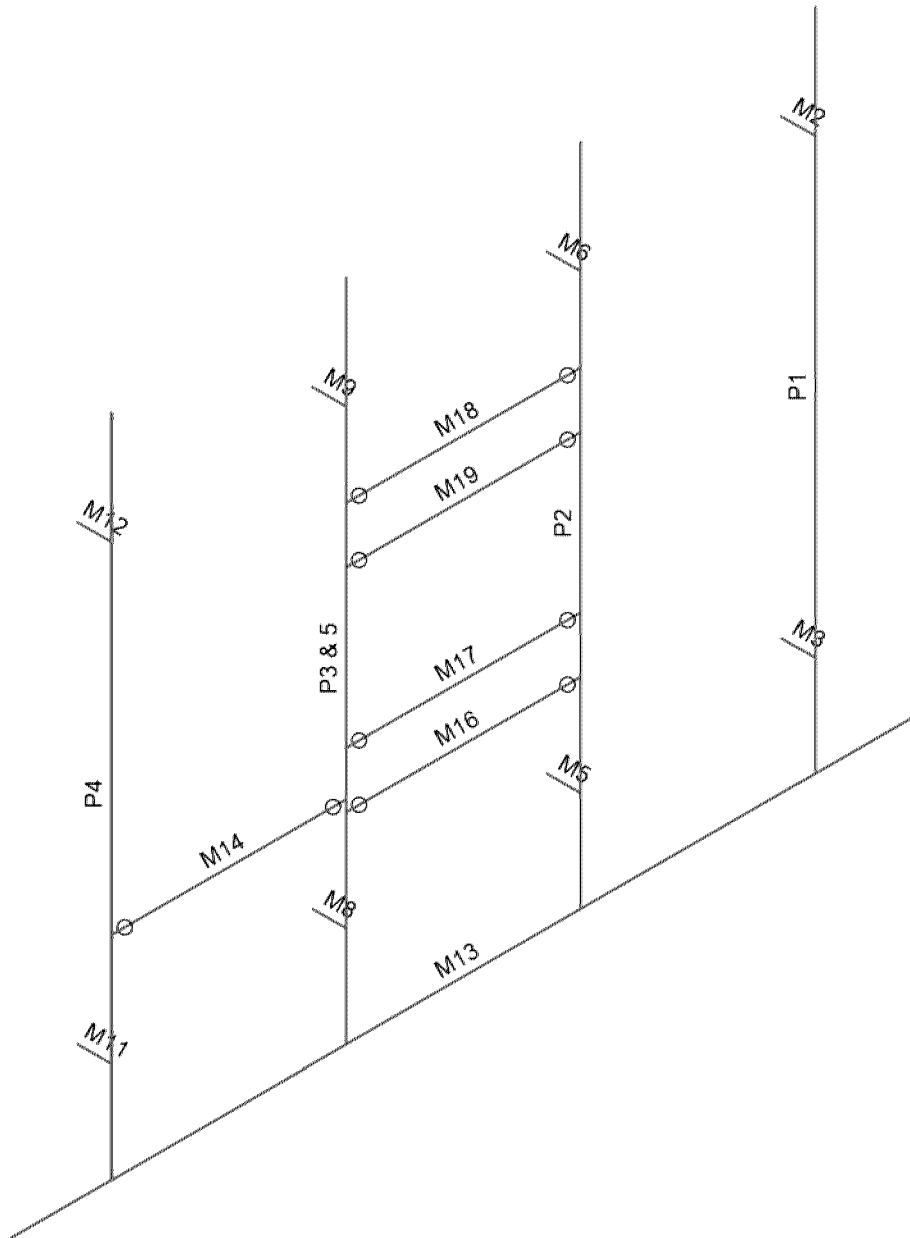
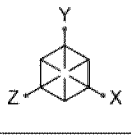

Envelope Only Solution

Herzog Engineering, LLC.

JJC

211426

MIN Killebrew - X Sector

MEMBER LABELS - 2

Sep 17, 2021

211426 MIN Killebrew X Sector.r3d



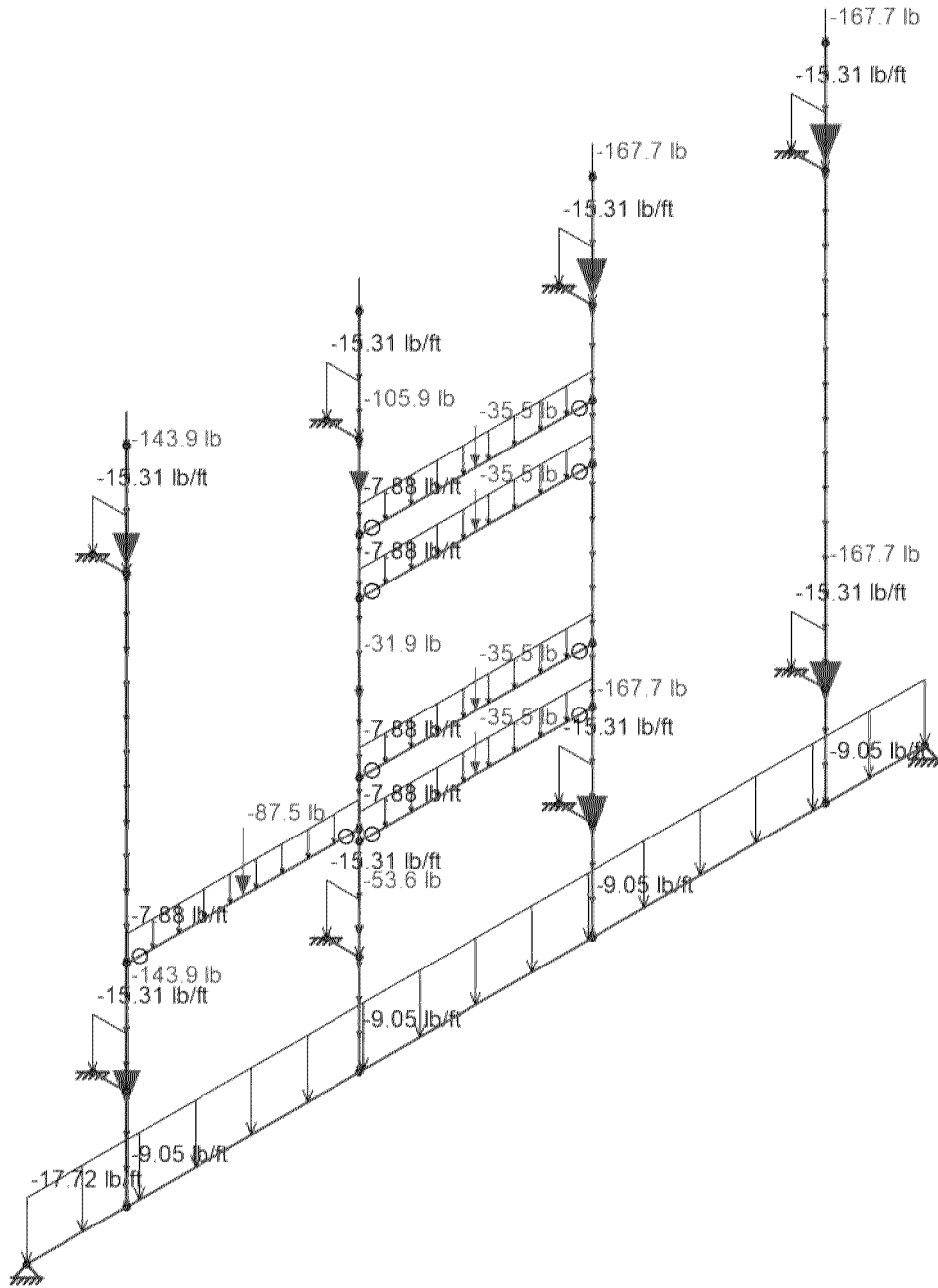
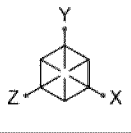

Loads: BLC 3, Ice Load  
Envelope Only Solution

Herzog Engineering, LLC.

MIN Killebrew - X Sector

ICE LOAD - 4

JJC

Sep 17, 2021

211426

211426 MIN Killebrew X Sector.r3d

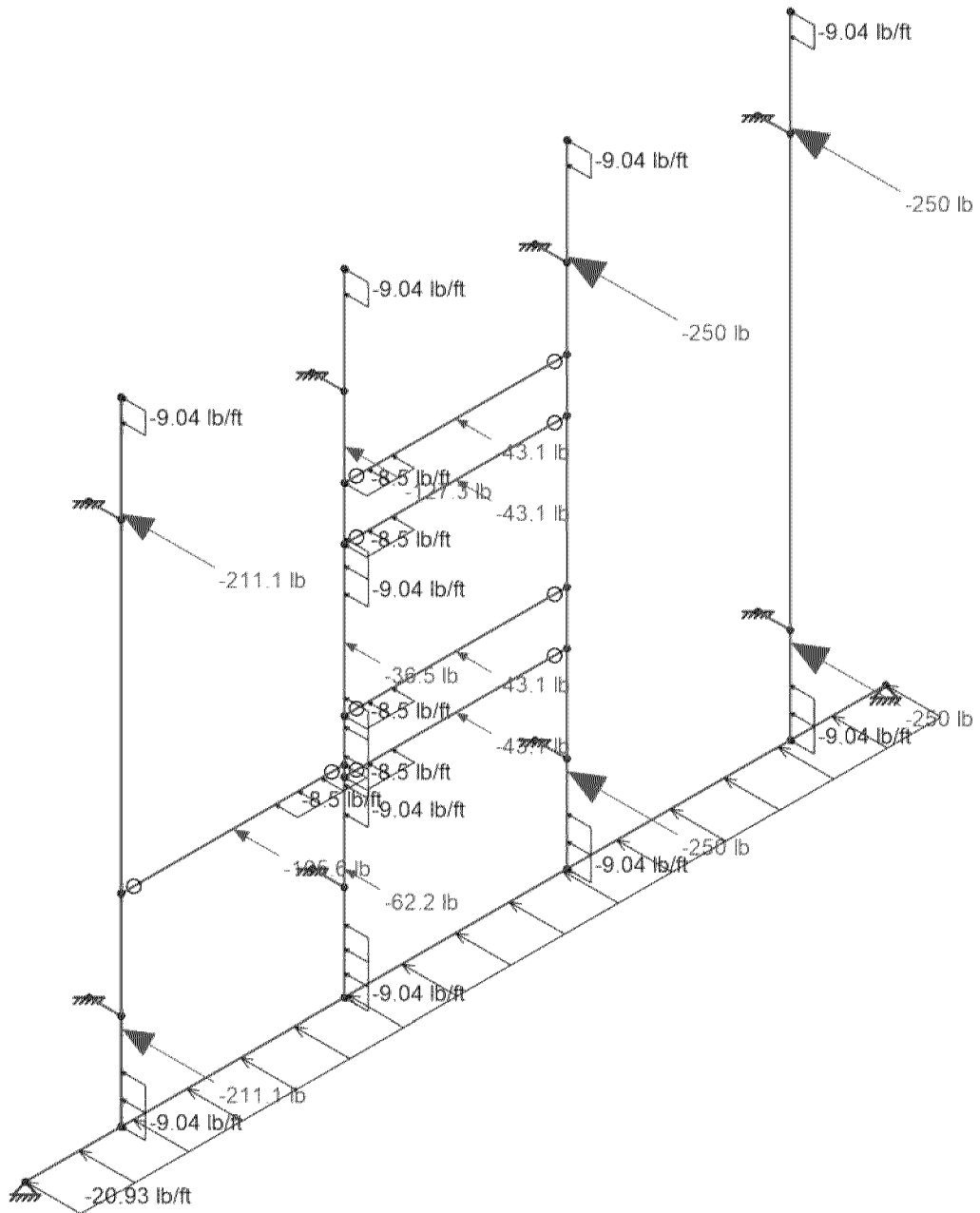
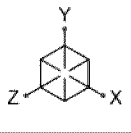

Loads: BLC 4, WLx  
Envelope Only Solution

Herzog Engineering, LLC.

JJC

211426

MIN Killebrew - X Sector

WIND LOAD (+X) - 5

Sep 17, 2021

211426 MIN Killebrew X Sector.r3d

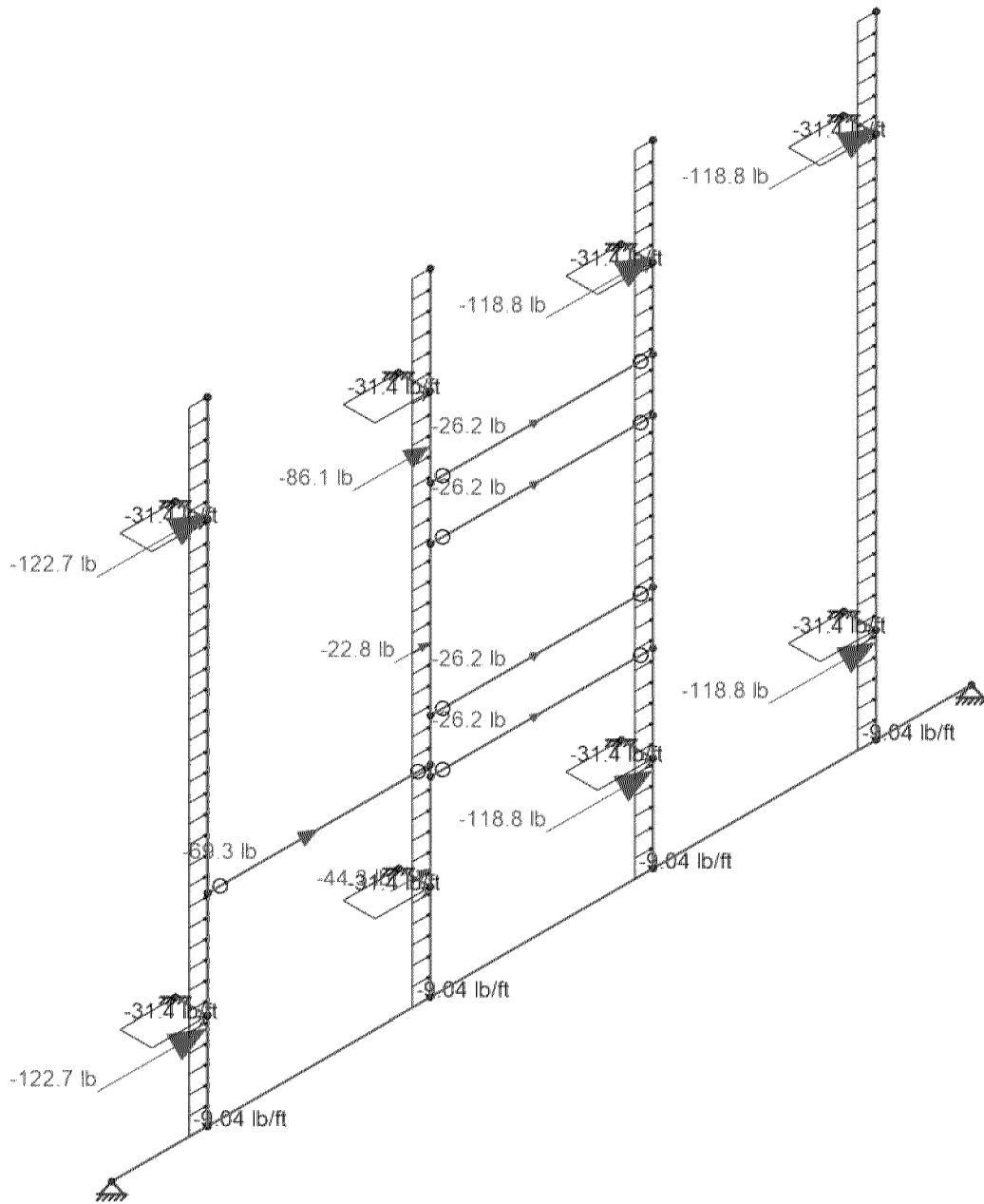
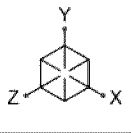

Loads: BLC 5, WLz  
Envelope Only Solution

Herzog Engineering, LLC.  
JJC  
211426

MIN Killebrew - X Sector

WIND LOAD (+Z) - 6

Sep 17, 2021

211426 MIN Killebrew X Sector.r3d

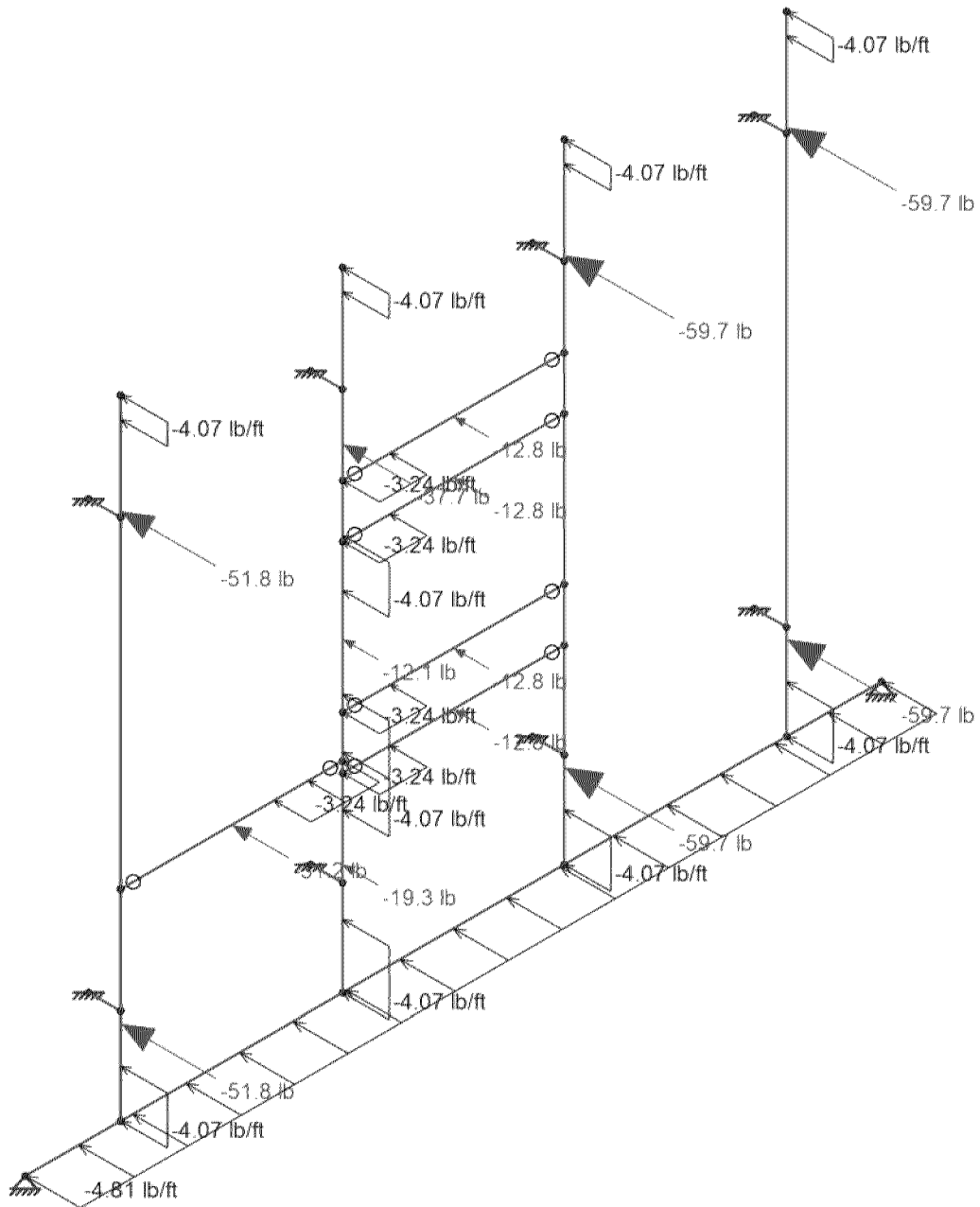
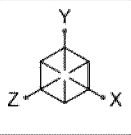

Loads: BLC 6, WLx on Ice Envelope Only Solution

Herzog Engineering, LLC.

JJC

211426

MIN Killebrew - X Sector

WIND ON ICE (+X) - 7

Sep 17, 2021

211426 MIN Killebrew X Sector.r3d

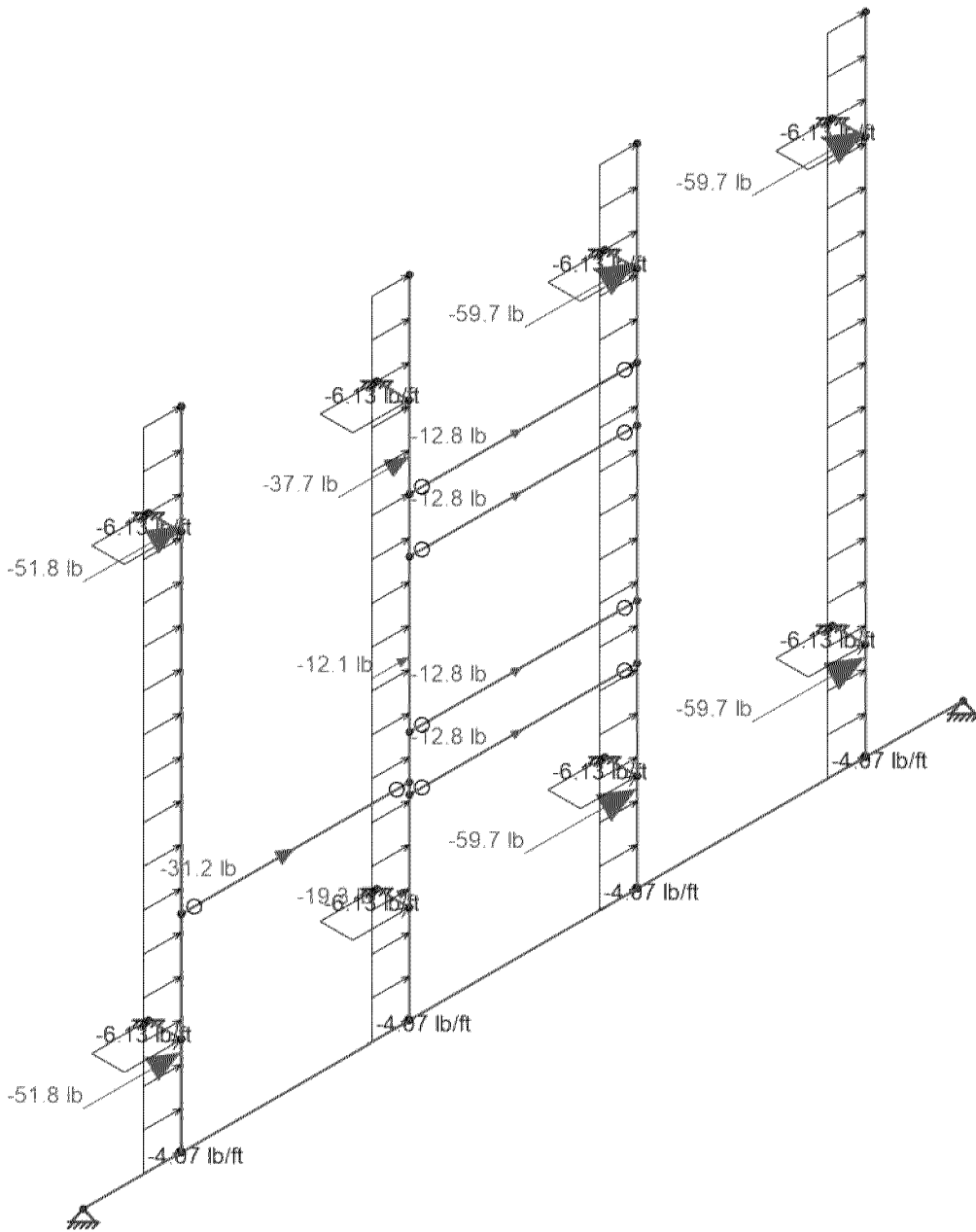
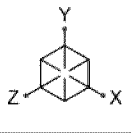

Loads: BLC 7, WLz on Ice  
Envelope Only Solution

Herzog Engineering, LLC.

MIN Killebrew - X Sector

WIND ON ICE (+Z) - 8

JJC

Sep 17, 2021

211426

211426 MIN Killebrew X Sector.r3d



Company : Herzog Engineering, LLC.  
 Designer : JJC  
 Job Number : 211426  
 Model Name : MIN Killebrew - X Sector

9/17/2021  
 12:06:28 PM  
 Checked By : \_\_\_\_\_

**Member Primary Data**

	Label	I Node	J Node	Rotate(deg)	Section/Shape	Type	Design List	Material	Design Rule
1	P1	N3	N2		2.5" SCH 40 MOUNTING PIPE	Column	Pipe	A53 Gr.B	Typical
2	M2	N4	N1		PL5x5x1/4 BRACKET	Beam	RECT	A36 Gr.36	Typical
3	M3	N6	N5		PL5x5x1/4 BRACKET	Beam	RECT	A36 Gr.36	Typical
4	P2	N9	N12		2.5" SCH 40 MOUNTING PIPE	Column	Pipe	A53 Gr.B	Typical
5	M5	N14	N10		PL5x5x1/4 BRACKET	Beam	RECT	A36 Gr.36	Typical
6	M6	N15	N11		PL5x5x1/4 BRACKET	Beam	RECT	A36 Gr.36	Typical
7	P3 & 5	N16	N19		2.5" SCH 40 MOUNTING PIPE	Column	Pipe	A53 Gr.B	Typical
8	M8	N20	N17		PL5x5x1/4 BRACKET	Beam	RECT	A36 Gr.36	Typical
9	M9	N21	N18		PL5x5x1/4 BRACKET	Beam	RECT	A36 Gr.36	Typical
10	P4	N22	N25		2.5" SCH 40 MOUNTING PIPE	Column	Pipe	A53 Gr.B	Typical
11	M11	N26	N23		PL5x5x1/4 BRACKET	Beam	RECT	A36 Gr.36	Typical
12	M12	N27	N24		PL5x5x1/4 BRACKET	Beam	RECT	A36 Gr.36	Typical
13	M13	N8	N13	90	HSS	Beam	SquareTube	A500 Gr.B Rect	Typical
14	M14	N32	N35		Unistrut	Beam	None	A653 SS Gr33	Typical
15	M16	N29	N28		Unistrut	Beam	None	A653 SS Gr33	Typical
16	M17	N34	N33		Unistrut	Beam	None	A653 SS Gr33	Typical
17	M18	N36	N37		Unistrut	Beam	None	A653 SS Gr33	Typical
18	M19	N38	N39		Unistrut	Beam	None	A653 SS Gr33	Typical

**Hot Rolled Steel Section Sets**

	Label	Shape	Type	Design List	Material	Design Rule	Area [in <sup>2</sup> ]	Iyy [in <sup>4</sup> ]	Izz [in <sup>4</sup> ]	J [in <sup>4</sup> ]
1	PL5x5x1/4 BRACKET	PL6x0.25	Beam	RECT	A36 Gr.36	Typical	1.5	0.008	4.5	0.03
2	2.5" SCH 40 MOUNTING PIPE	PIPE 2.5	Column	Pipe	A53 Gr.B	Typical	1.61	1.45	1.45	2.89
3	HSS	HSS6X4X4	Beam	SquareTube	A500 Gr.B Rect	Typical	4.3	11.1	20.9	23.6

**Hot Rolled Steel Design Parameters**

	Label	Shape	Length [in]	Lb y-y [in]	Lcomp top [in]	Lcomp bot [in]	K y-y	K z-z	Function
1	P1	2.5" SCH 40 MOUNTING PIPE	119				2.1	2.1	Lateral
2	M2	PL5x5x1/4 BRACKET	6				0.65	0.65	Lateral
3	M3	PL5x5x1/4 BRACKET	6				0.65	0.65	Lateral
4	P2	2.5" SCH 40 MOUNTING PIPE	119				2.1	2.1	Lateral
5	M5	PL5x5x1/4 BRACKET	6				0.65	0.65	Lateral
6	M6	PL5x5x1/4 BRACKET	6				0.65	0.65	Lateral
7	P3 & 5	2.5" SCH 40 MOUNTING PIPE	119				2.1	2.1	Lateral
8	M8	PL5x5x1/4 BRACKET	6				0.65	0.65	Lateral
9	M9	PL5x5x1/4 BRACKET	6				0.65	0.65	Lateral
10	P4	2.5" SCH 40 MOUNTING PIPE	119				2.1	2.1	Lateral
11	M11	PL5x5x1/4 BRACKET	6				0.65	0.65	Lateral
12	M12	PL5x5x1/4 BRACKET	6				0.65	0.65	Lateral
13	M13	HSS	162	Segment	Lbyy	Segment	1	1	Lateral

**Hot Rolled Steel Properties**

	Label	E [ksi]	G [ksi]	Nu	Therm. Coeff. [1e <sup>5</sup> °F <sup>-1</sup> ]	Density [k/ft <sup>3</sup> ]	Yield [ksi]	Ry	Fu [ksi]	Rt
1	A992	29000	11154	0.3	0.65	0.49	50	1.1	65	1.1
2	A36 Gr.36	29000	11154	0.3	0.65	0.49	36	1.5	58	1.2
3	A572 Gr.50	29000	11154	0.3	0.65	0.49	50	1.1	65	1.1
4	A500 Gr.B RND	29000	11154	0.3	0.65	0.527	42	1.4	58	1.3
5	A500 Gr.B Rect	29000	11154	0.3	0.65	0.527	46	1.4	58	1.3
6	A53 Gr.B	29000	11154	0.3	0.65	0.49	35	1.6	60	1.2
7	A1085	29000	11154	0.3	0.65	0.49	50	1.4	65	1.3
8	A913 Gr.65	29000	11154	0.3	0.65	0.49	65	1.1	80	1.1



Company : Herzog Engineering, LLC.  
 Designer : JJC  
 Job Number : 211426  
 Model Name : MIN Killebrew - X Sector

9/17/2021  
 12:06:28 PM  
 Checked By : \_\_\_\_\_

**Basic Load Cases**

	BLC Description	Category	Y Gravity	Point	Distributed
1	DL Mount	DL	-1		
2	DL Equipment	DL		14	
3	Ice Load	OL1		14	18
4	WLx	WLX		14	16
5	WLz	WLZ		14	12
6	WLx on Ice	OL2		14	16
7	WLz on Ice	OL3		14	12

**Load Combinations**

	Description	Solve	P-Delta	BLC Factor	BLC Factor	BLC Factor	BLC Factor	BLC Factor	BLC Factor	BLC Factor	BLC Factor	BLC Factor	BLC Factor
1	1.4DL+1.4DLequip	Yes	Y	1	1.4	2	1.4						
2	1.2DL+1.2DLequip+1.0WL (0 deg)	Yes	Y	1	1.2	2	1.2	4	1				
3	1.2DL+1.2DLequip+1.0WL (30 deg)	Yes	Y	1	1.2	2	1.2	4	0.87	5	0.5		
4	1.2DL+1.2DLequip+1.0WL (60 deg)	Yes	Y	1	1.2	2	1.2	4	0.5	5	0.87		
5	1.2DL+1.2DLequip+1.0WL (90 deg)	Yes	Y	1	1.2	2	1.2	5	1				
6	1.2DL+1.2DLequip+1.0WL (120 deg)	Yes	Y	1	1.2	2	1.2	4	-0.5	5	0.87		
7	1.2DL+1.2DLequip+1.0WL (150 deg)	Yes	Y	1	1.2	2	1.2	4	-0.87	5	0.5		
8	1.2DL+1.2DLequip+1.0WL (180 deg)	Yes	Y	1	1.2	2	1.2	4	-1				
9	1.2DL+1.2DLequip+1.0WL (210 deg)	Yes	Y	1	1.2	2	1.2	4	-0.87	5	-0.5		
10	1.2DL+1.2DLequip+1.0WL (240 deg)	Yes	Y	1	1.2	2	1.2	4	-0.5	5	-0.87		
11	1.2DL+1.2DLequip+1.0WL (270 deg)	Yes	Y	1	1.2	2	1.2	5	-1				
12	1.2DL+1.2DLequip+1.0WL (300 deg)	Yes	Y	1	1.2	2	1.2	4	0.5	5	-0.87		
13	1.2DL+1.2DLequip+1.0WL (330 deg)	Yes	Y	1	1.2	2	1.2	4	0.87	5	-0.5		
14	0.9DL+0.9DLequip+1.0WL (0 deg)	Yes	Y	1	0.9	2	0.9	4	1				
15	0.9DL+0.9DLequip+1.0WL (30 deg)	Yes	Y	1	0.9	2	0.9	4	0.87	5	0.5		
16	0.9DL+0.9DLequip+1.0WL (60 deg)	Yes	Y	1	0.9	2	0.9	4	0.5	5	0.87		
17	0.9DL+0.9DLequip+1.0WL (90 deg)	Yes	Y	1	0.9	2	0.9	5	1				
18	0.9DL+0.9DLequip+1.0WL (120 deg)	Yes	Y	1	0.9	2	0.9	4	-0.5	5	0.87		
19	0.9DL+0.9DLequip+1.0WL (150 deg)	Yes	Y	1	0.9	2	0.9	4	-0.87	5	0.5		
20	0.9DL+0.9DLequip+1.0WL (180 deg)	Yes	Y	1	0.9	2	0.9	4	-1				
21	0.9DL+0.9DLequip+1.0WL (210 deg)	Yes	Y	1	0.9	2	0.9	4	-0.87	5	-0.5		
22	0.9DL+0.9DLequip+1.0WL (240 deg)	Yes	Y	1	0.9	2	0.9	4	-0.5	5	-0.87		
23	0.9DL+0.9DLequip+1.0WL (270 deg)	Yes	Y	1	0.9	2	0.9	5	-1				
24	0.9DL+0.9DLequip+1.0WL (300 deg)	Yes	Y	1	0.9	2	0.9	4	0.5	5	-0.87		
25	0.9DL+0.9DLequip+1.0WL (330 deg)	Yes	Y	1	0.9	2	0.9	4	0.87	5	-0.5		
26	1.2DL+1.2DLequip+1.0Ice+1.0WLice (0 deg)	Yes	Y	1	1.2	2	1.2	3	1	6	1		
27	1.2DL+1.2DLequip+1.0Ice+1.0WLice (30 deg)	Yes	Y	1	1.2	2	1.2	3	1	6	0.87	7	0.5
28	1.2DL+1.2DLequip+1.0Ice+1.0WLice (60 deg)	Yes	Y	1	1.2	2	1.2	3	1	6	0.5	7	0.87
29	1.2DL+1.2DLequip+1.0Ice+1.0WLice (90 deg)	Yes	Y	1	1.2	2	1.2	3	1	7	1		
30	1.2DL+1.2DLequip+1.0Ice+1.0WLice (120 deg)	Yes	Y	1	1.2	2	1.2	3	1	6	-0.5	7	0.87
31	1.2DL+1.2DLequip+1.0Ice+1.0WLice (150 deg)	Yes	Y	1	1.2	2	1.2	3	1	6	-0.87	7	0.5
32	1.2DL+1.2DLequip+1.0Ice+1.0WLice (180 deg)	Yes	Y	1	1.2	2	1.2	3	1	6	-1		
33	1.2DL+1.2DLequip+1.0Ice+1.0WLice (210 deg)	Yes	Y	1	1.2	2	1.2	3	1	6	-0.87	7	-0.5
34	1.2DL+1.2DLequip+1.0Ice+1.0WLice (240 deg)	Yes	Y	1	1.2	2	1.2	3	1	6	-0.5	7	-0.87
35	1.2DL+1.2DLequip+1.0Ice+1.0WLice (270 deg)	Yes	Y	1	1.2	2	1.2	3	1	7	-1		
36	1.2DL+1.2DLequip+1.0Ice+1.0WLice (300 deg)	Yes	Y	1	1.2	2	1.2	3	1	6	0.5	7	-0.87
37	1.2DL+1.2DLequip+1.0Ice+1.0WLice (330 deg)	Yes	Y	1	1.2	2	1.2	3	1	6	0.87	7	-0.5
38	DL+DLequip		Y	1	1	2	1						
39	DL+DLequip+0.6WL (0 deg)		Y	1	1	2	1	4	0.6				
40	DL+DLequip+0.6WL (90 deg)		Y	1	1	2	1	5	0.6				
41	DL+DLequip+0.75(0.6WL (0 deg))		Y	1	1	2	1	4	0.45				
42	DL+DLequip+0.75(0.6WL (90 deg))		Y	1	1	2	1	5	0.45				
43	0.6DL+0.6DLequip+0.6WL (0 deg)		Y	1	0.6	2	0.6	4	0.6				
44	0.6DL+0.6DLequip+0.6WL (90 deg)		Y	1	0.6	2	0.6	5	0.6				



Company : Herzog Engineering, LLC.  
 Designer : JJC  
 Job Number : 211426  
 Model Name : MIN Killebrew - X Sector

9/17/2021  
 12:06:28 PM  
 Checked By : \_\_\_\_\_

**Load Combinations (Continued)**

	Description	Solve	P-Delta	BLC Factor	BLC Factor	BLC Factor	BLC Factor	BLC Factor	BLC Factor	BLC Factor	BLC Factor
45	0.6DL+0.6DLequip		Y	1	0.6	2	0.6				
46	DL+DLequip+0.7lce		Y	1	1	2	1	3	0.7		
47	DL+DLequip+0.7lce+0.7WLice (0 deg)		Y	1	1	2	1	3	0.7	6	0.7
48	DL+DLequip+0.7lce+0.7WLice (90 deg)		Y	1	1	2	1	3	0.7	7	0.7
49	0.6DL+0.6DLequip+0.7lce+0.7WLice (0 deg)		Y	1	0.6	2	0.6	3	0.7	6	0.7
50	0.6DL+0.6DLequip+0.7lce+0.7WLice (90 deg)		Y	1	0.6	2	0.6	3	0.7	7	0.7

**Envelope AISC 15TH (360-16): LRFD Member Steel Code Checks**

Member	Shape	Code	Check	Loc[in]	LC	Shear	Check	Loc[in]	Dir	LC	phi*Pnc [lb]	phi*Pnt [lb]	phi*Mn y-y [k-in]	phi*Mn z-z [k-in]	Cb	Eqn
1	P1	PIPE 2.5	0.047	99.167	36	0.024	0		5	5245.36	50715	43.155	43.155	1.822	H1-1b*	
2	M2	PL6x0.25	0.197	0	11	0.017	0	y	37	41674.313	48600	3.038	72.9	1.755	H1-1b	
3	M3	PL6x0.25	0.067	0	11	0.025	0	y	35	41674.313	48600	3.038	72.9	1.841	H1-1b	
4	P2	PIPE 2.5	0.057	0	5	0.029	17.354		3	5245.36	50715	43.155	43.155	1.822	H1-1b	
5	M5	PL6x0.25	0.101	0	5	0.035	0	y	29	41674.313	48600	3.038	72.9	1.741	H1-1b	
6	M6	PL6x0.25	0.225	0	5	0.029	0	y	29	41674.313	48600	3.038	72.9	1.756	H1-1b	
7	P3 & 5	PIPE 2.5	0.084	18.594	2	0.022	0		5	5245.36	50715	43.155	43.155	2.325	H1-1b	
8	M8	PL6x0.25	0.1	0	5	0.037	0	y	28	41674.313	48600	3.038	72.9	1.771	H1-1b	
9	M9	PL6x0.25	0.193	0	5	0.035	0	y	29	41674.313	48600	3.038	72.9	1.75	H1-1b	
10	P4	PIPE 2.5	0.062	0	11	0.029	0		11	5245.36	50715	43.155	43.155	2.158	H1-1b	
11	M11	PL6x0.25	0.103	0	5	0.03	0	y	29	41674.313	48600	3.038	72.9	1.81	H1-1b	
12	M12	PL6x0.25	0.214	0	5	0.021	0	y	29	41674.313	48600	3.038	72.9	1.76	H1-1b	
13	M13	HSS6x4x4	0.007	16.875	24	0.003	59.062	z	3	123802.068	178020	267.03	353.142	1.652	H1-1b	

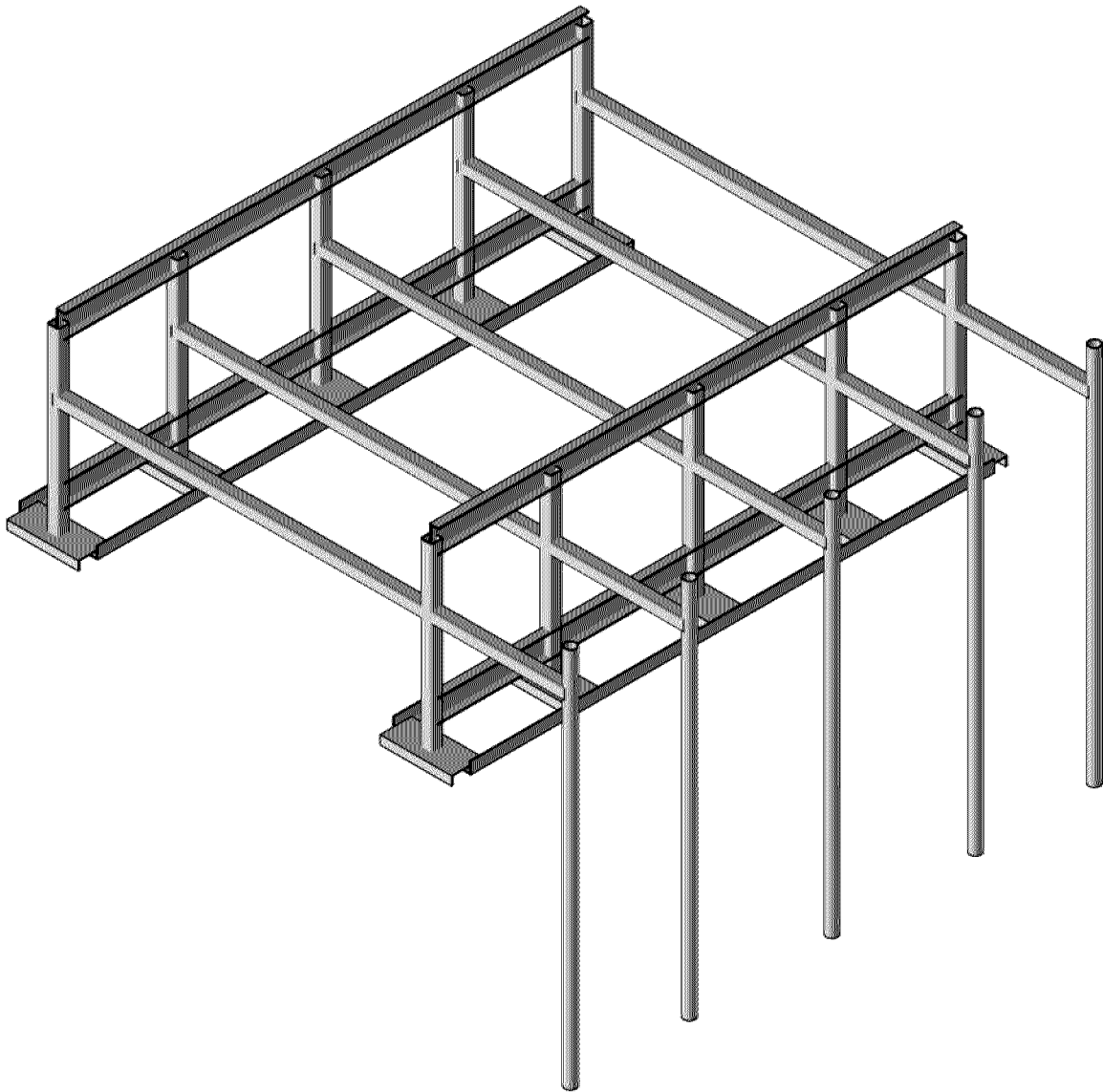
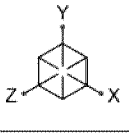

Envelope Only Solution

Herzog Engineering, LLC.

JJC

211426

MIN Killebrew - Y Sector

3D VIEW - 1

Sep 17, 2021

211426 MIN Killebrew Y Sector.r3d



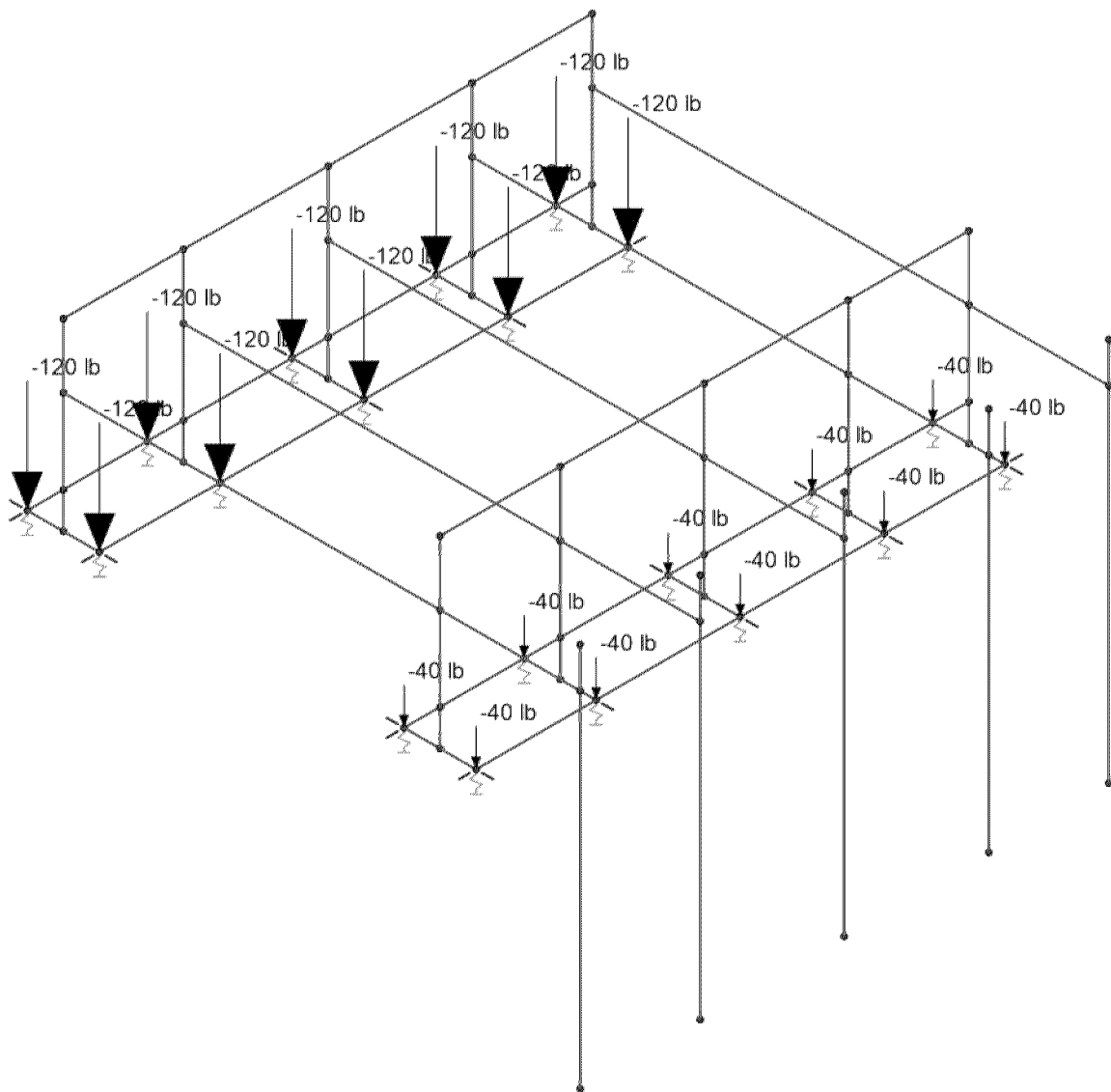
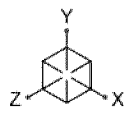

Loads: BLC 1, DL Mount  
Envelope Only Solution

Herzog Engineering, LLC.	MIN Killebrew - Y Sector	DL MOUNT - 3
JJC		Sep 17, 2021
211426		211426 MIN Killebrew Y Sector.r3d

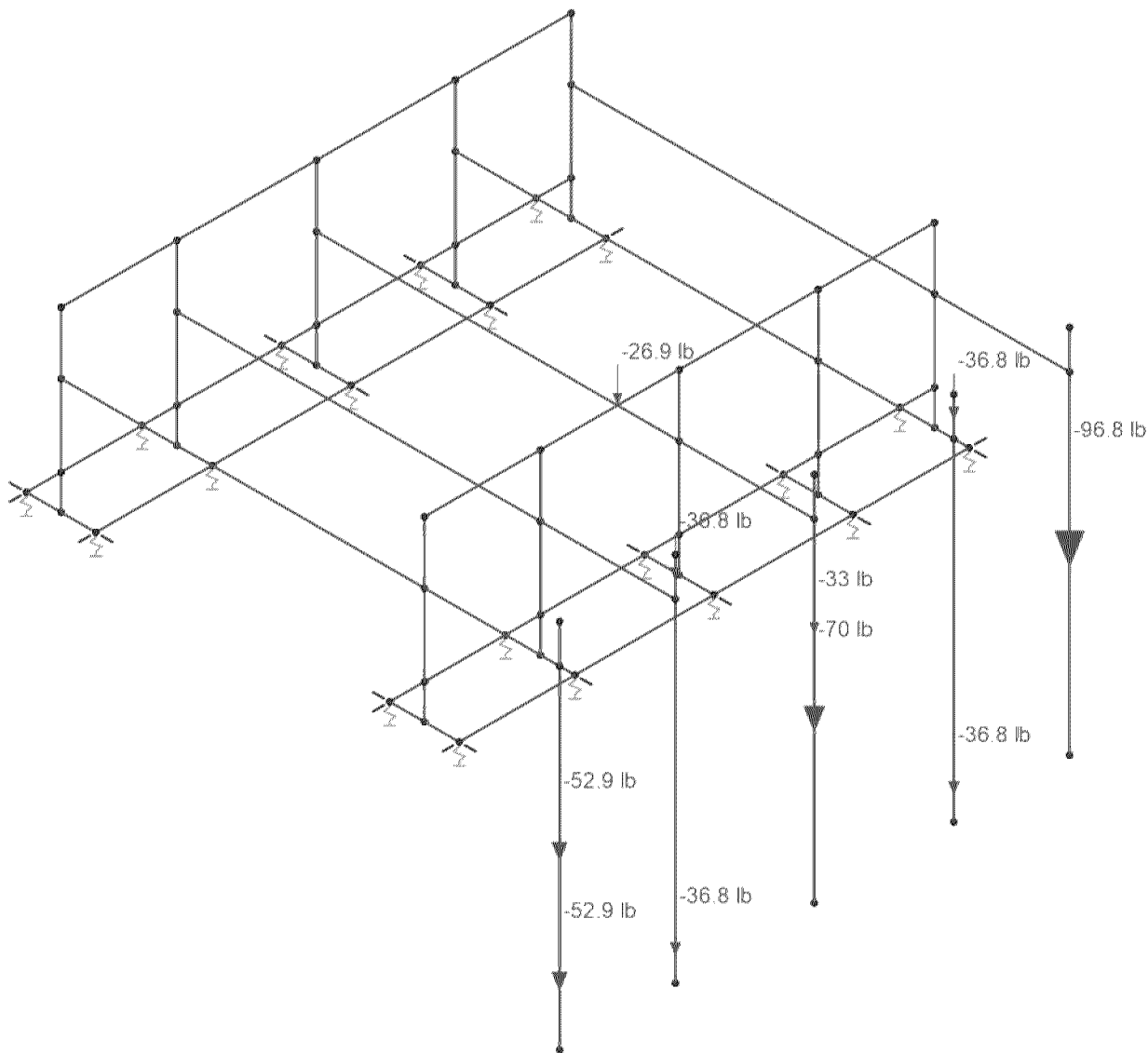
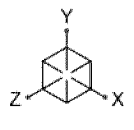

Loads: BLC 2, DL Equipment  
Envelope Only Solution

Herzog Engineering, LLC.	MIN Killebrew - Y Sector	DL EQUIPMENT - 4
JJC		Sep 17, 2021
211426		211426 MIN Killebrew Y Sector.r3d

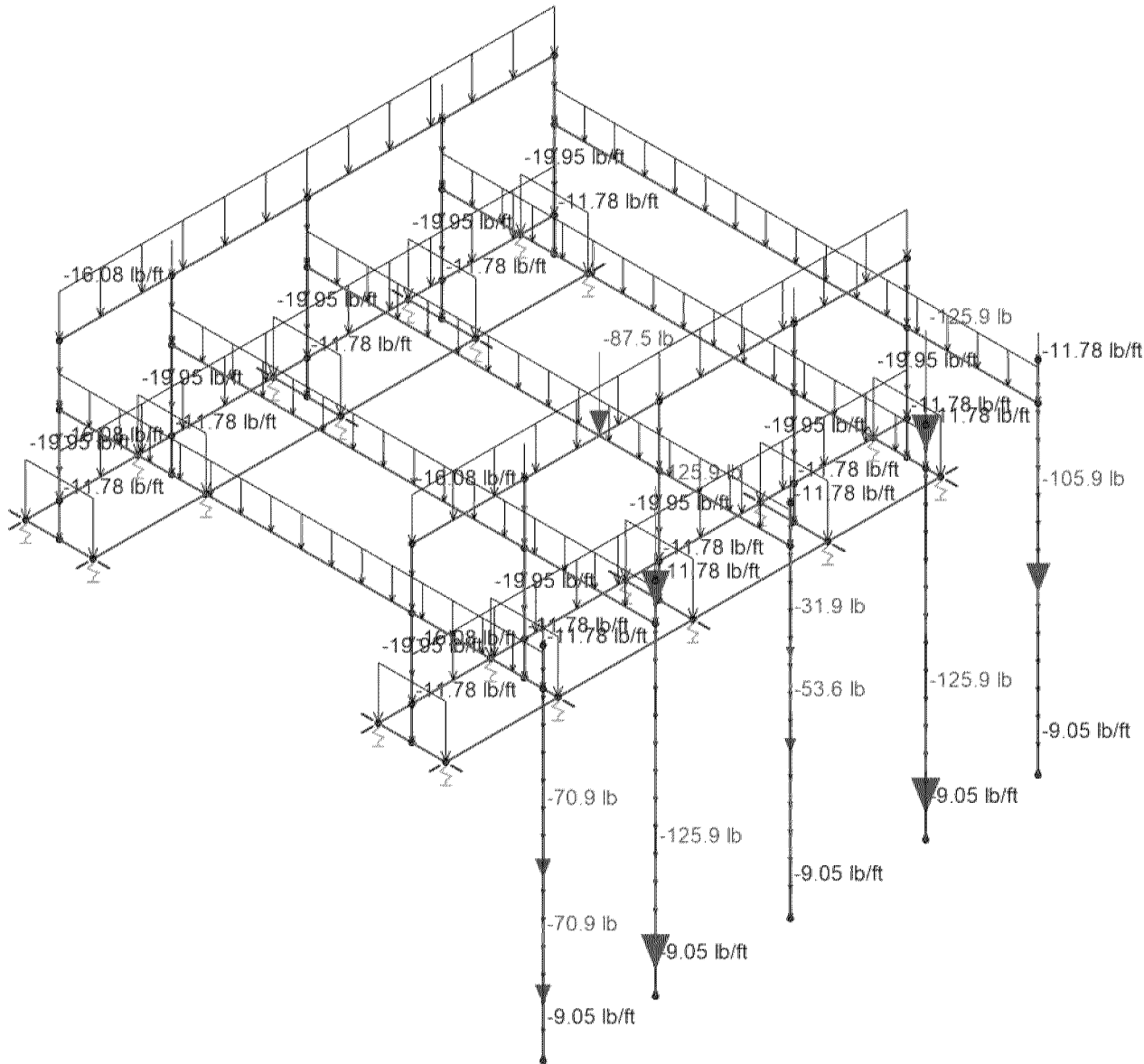
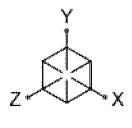

Loads: BLC 3, Ice Load  
Envelope Only Solution

Herzog Engineering, LLC.	MIN Killebrew - Y Sector	ICE LOAD - 5
JJC		Sep 17, 2021
211426		211426 MIN Killebrew Y Sector.r3d

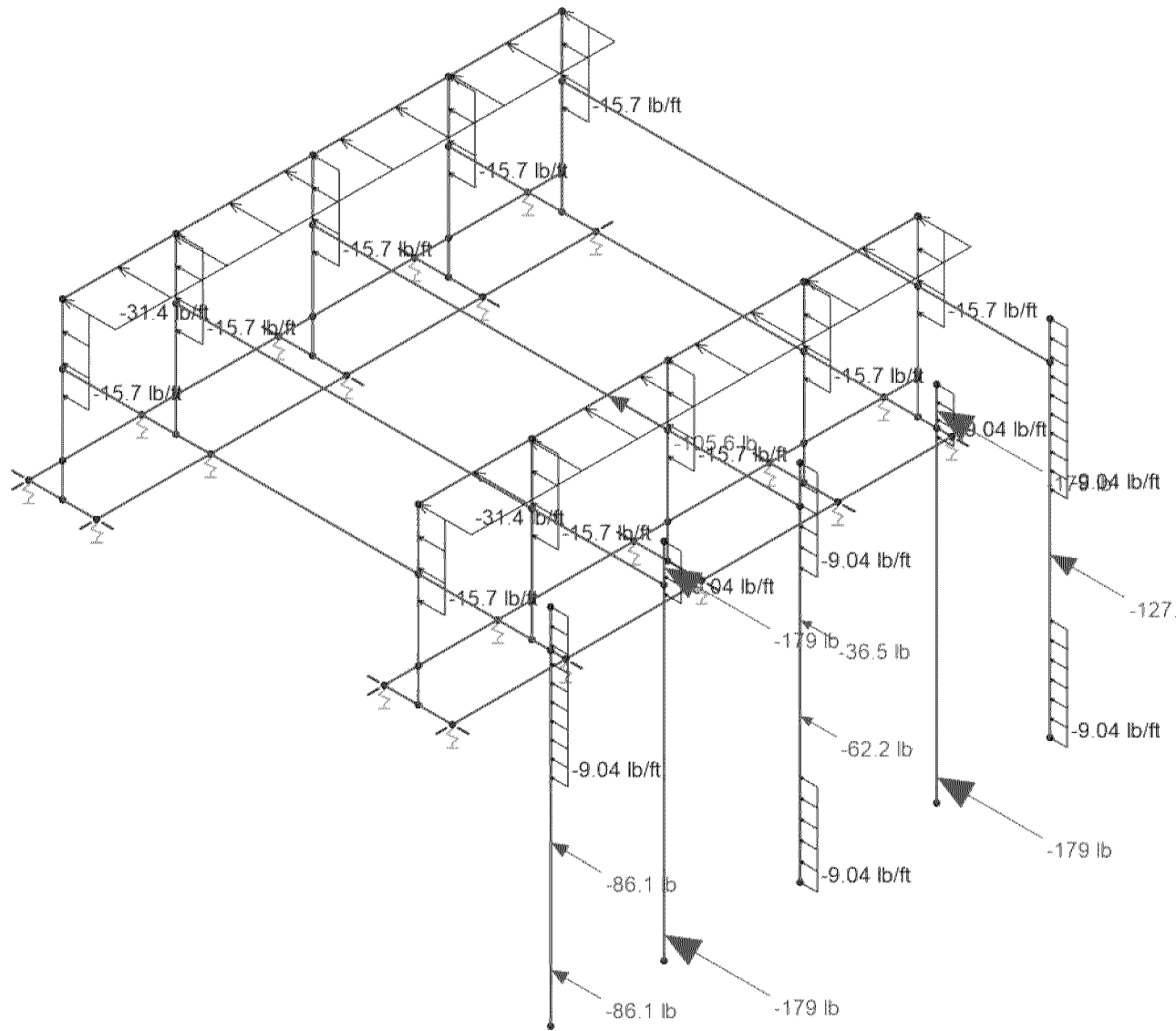
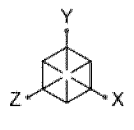

Loads: BLC 4, WLx  
Envelope Only Solution

Herzog Engineering, LLC.	MIN Killebrew - Y Sector	WIND LOAD (+X) - 6
JJC		Sep 17, 2021
211426		211426 MIN Killebrew Y Sector.r3d

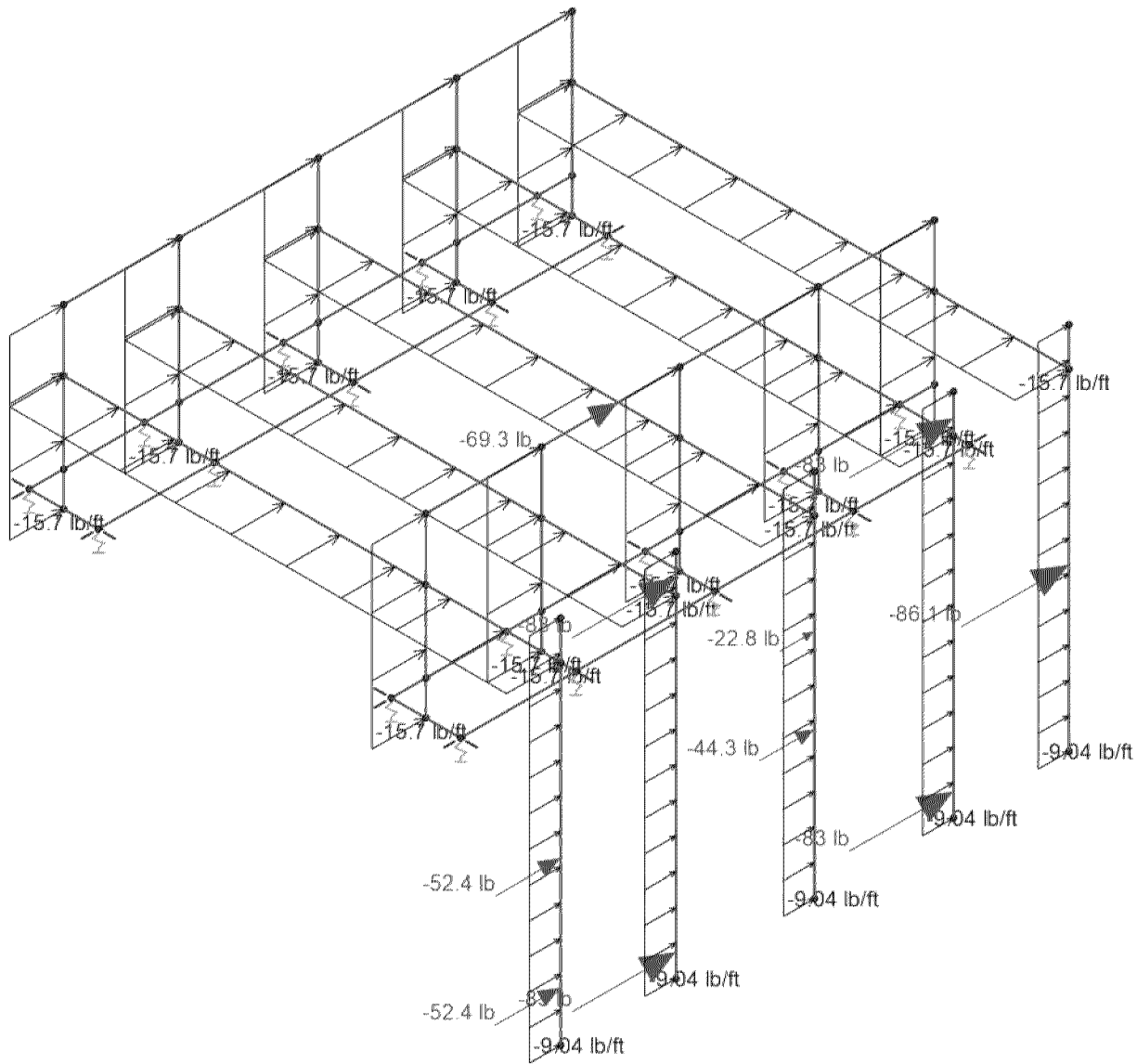
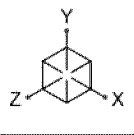

Loads: BLC 5, WLz  
Envelope Only Solution

Herzog Engineering, LLC.	MIN Killebrew - Y Sector	WIND LOAD (+Z) - 7
JJC		Sep 17, 2021
211426		211426 MIN Killebrew Y Sector.r3d

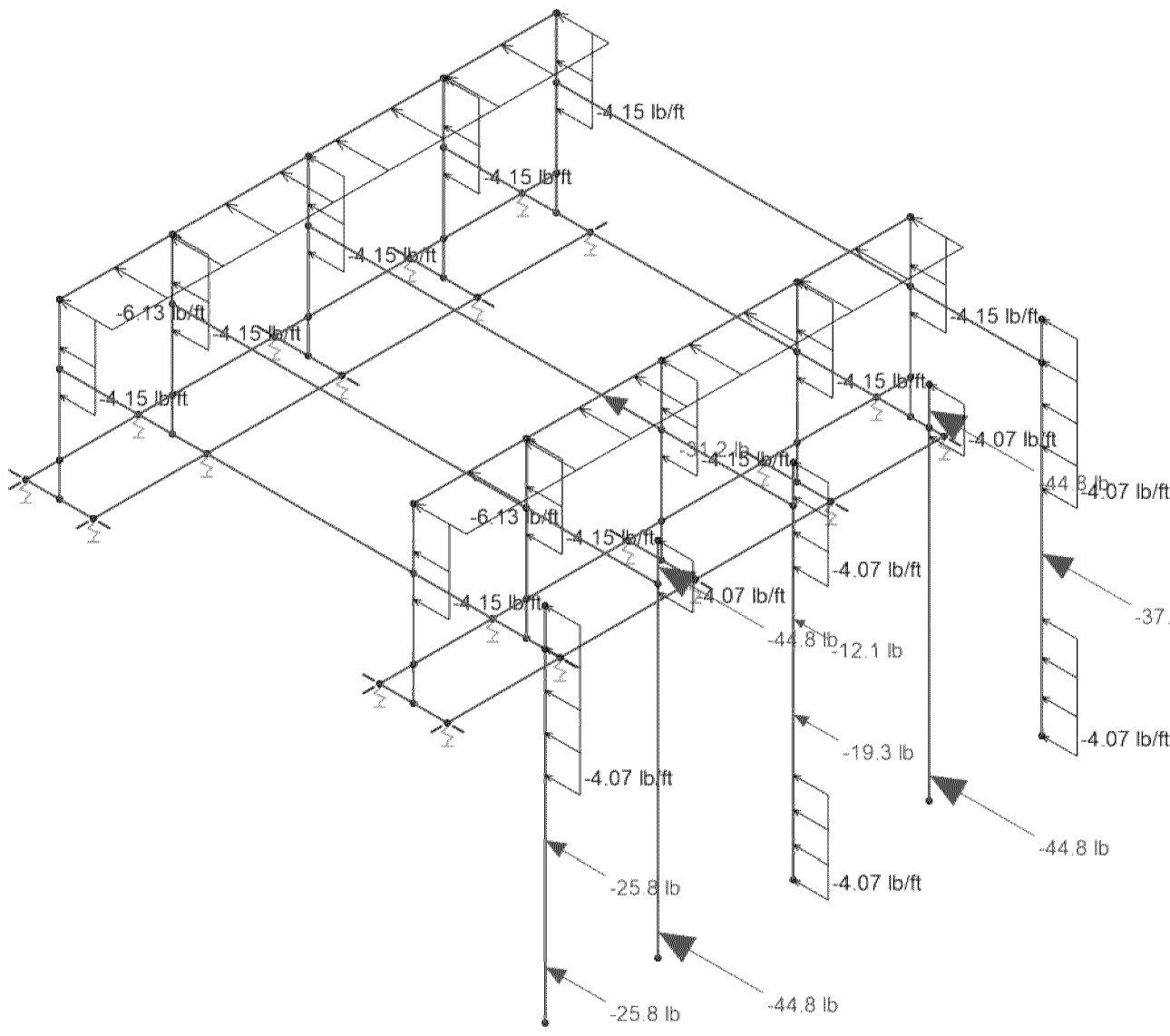
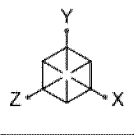

Loads: BLC 6, WLx on Ice  
Envelope Only Solution

Herzog Engineering, LLC.	MIN Killebrew - Y Sector	WIND ON ICE (+X) - 8
JJC		Sep 17, 2021
211426		211426 MIN Killebrew Y Sector.r3d

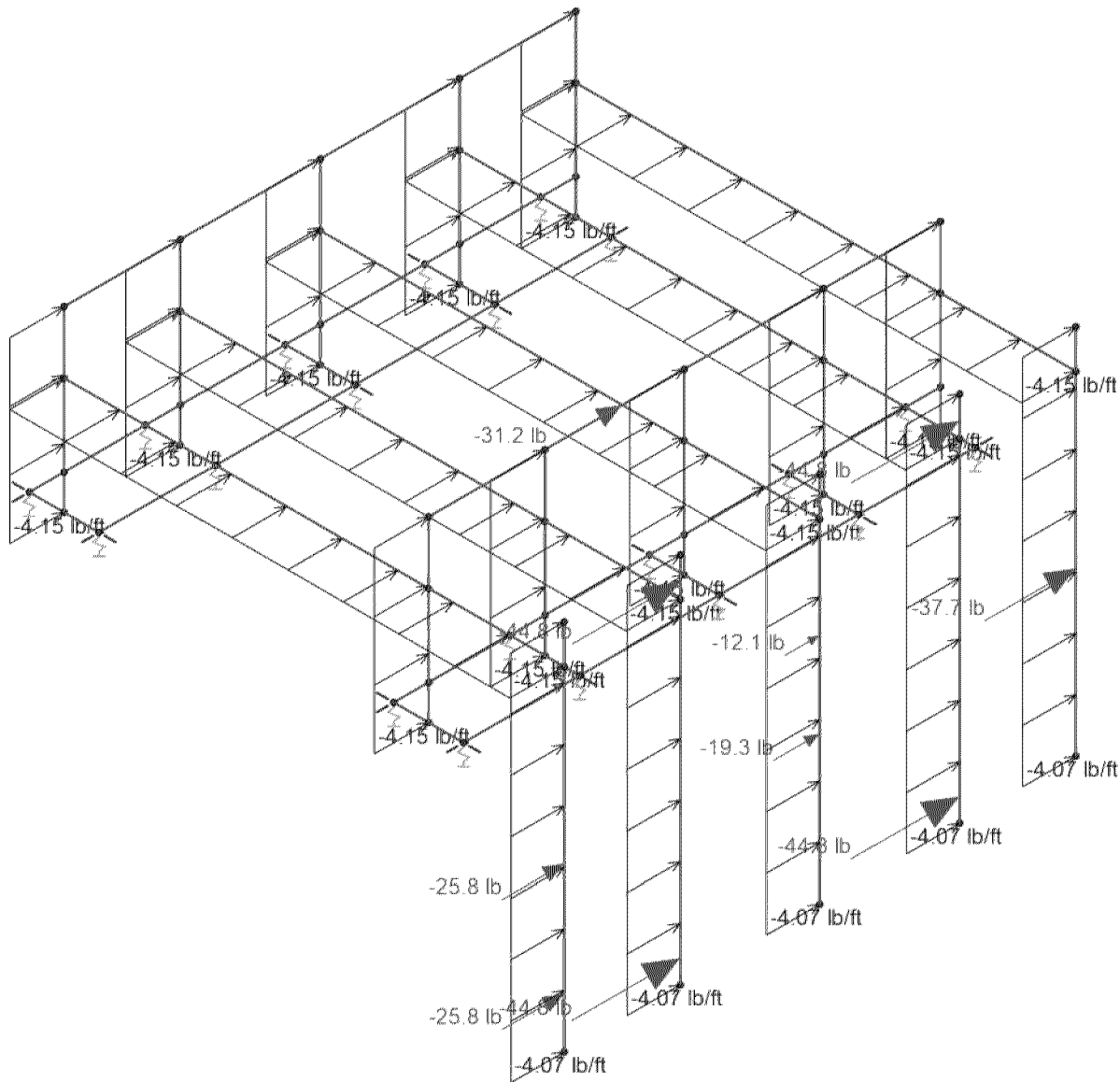
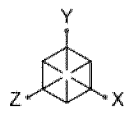

Loads: BLC 7, WLz on Ice  
Envelope Only Solution

Herzog Engineering, LLC.	MIN Killebrew - Y Sector	WIND ON ICE (+Z) - 9
JJC		Sep 17, 2021
211426		211426 MIN Killebrew Y Sector.r3d



Company : Herzog Engineering, LLC.  
 Designer : JJC  
 Job Number : 211426  
 Model Name : MIN Killebrew - Y Sector

9/17/2021  
 12:16:30 PM  
 Checked By : \_\_\_\_\_

**Member Primary Data**

	Label	I Node	J Node	Rotate(deg)	Section/Shape	Type	Design List	Material	Design Rule
1	P1	N3	N2		2.5" SCH 40 MOUNTING PIPE	Column	Pipe	A53 Gr.B	Typical
2	P2	N9	N12		2.5" SCH 40 MOUNTING PIPE	Column	Pipe	A53 Gr.B	Typical
3	P3	N16	N19		2.5" SCH 40 MOUNTING PIPE	Column	Pipe	A53 Gr.B	Typical
4	RRU	N22	N25		2.5" SCH 40 MOUNTING PIPE	Column	Pipe	A53 Gr.B	Typical
5	P5	N21	N20		2.5" SCH 40 MOUNTING PIPE	Column	Pipe	A53 Gr.B	Typical
6	M7	N24	N26		HSS3X3 BEAM	Beam	SquareTube	A500 Gr.B Rect	Typical
7	M8	N1	N23		HSS3X3 BEAM	Beam	SquareTube	A500 Gr.B Rect	Typical
8	M9	N18	N25A		HSS3X3 BEAM	Beam	SquareTube	A500 Gr.B Rect	Typical
9	M10	N11	N24A		HSS3X3 BEAM	Beam	SquareTube	A500 Gr.B Rect	Typical
10	M11	N19A	N27		HSS3X3 BEAM	Beam	SquareTube	A500 Gr.B Rect	Typical
11	M12	N46	N36		HSS3X3 POST	Column	SquareTube	A500 Gr.B Rect	Typical
12	M13	N43	N33		HSS3X3 POST	Column	SquareTube	A500 Gr.B Rect	Typical
13	M15	N45	N35A		HSS3X3 POST	Column	SquareTube	A500 Gr.B Rect	Typical
14	M16	N44	N34		HSS3X3 POST	Column	SquareTube	A500 Gr.B Rect	Typical
15	M17	N47	N37		HSS3X3 POST	Column	SquareTube	A500 Gr.B Rect	Typical
16	M18	N38	N31		HSS3X3 POST	Column	SquareTube	A500 Gr.B Rect	Typical
17	M19	N40	N28		HSS3X3 POST	Column	SquareTube	A500 Gr.B Rect	Typical
18	M20	N39	N30		HSS3X3 POST	Column	SquareTube	A500 Gr.B Rect	Typical
19	M21	N41	N29		HSS3X3 POST	Column	SquareTube	A500 Gr.B Rect	Typical
20	M22	N42	N32A		HSS3X3 POST	Column	SquareTube	A500 Gr.B Rect	Typical
21	M23	N62	N52	90	C8	Beam	Channel	A36 Gr.36	Typical
22	M24	N58	N48	90	C8	Beam	Channel	A36 Gr.36	Typical
23	M25	N67	N57	90	C8	Beam	Channel	A36 Gr.36	Typical
24	M26	N66	N56	90	C8	Beam	Channel	A36 Gr.36	Typical
25	M27	N59	N49	90	C8	Beam	Channel	A36 Gr.36	Typical
26	M28	N64	N54	90	C8	Beam	Channel	A36 Gr.36	Typical
27	M29	N60	N50	90	C8	Beam	Channel	A36 Gr.36	Typical
28	M30	N65	N55	90	C8	Beam	Channel	A36 Gr.36	Typical
29	M31	N63	N53	90	C8	Beam	Channel	A36 Gr.36	Typical
30	M32	N61	N51	90	C8	Beam	Channel	A36 Gr.36	Typical
31	M33	N62	N59		L3X3	Beam	Single Angle	A36 Gr.36	Typical
32	M34	N49	N52		L3X3	Beam	Single Angle	A36 Gr.36	Typical
33	M35	N64	N61		L3X3	Beam	Single Angle	A36 Gr.36	Typical
34	M36	N51	N54		L3X3	Beam	Single Angle	A36 Gr.36	Typical
35	M37	N72	N69		C6	Beam	Channel	A36 Gr.36	Typical
36	M38	N36	N37		C6	Beam	Channel	A36 Gr.36	Typical
37	M39	N74	N71		C6	Beam	Channel	A36 Gr.36	Typical
38	M40	N31	N32A		C6	Beam	Channel	A36 Gr.36	Typical

**Hot Rolled Steel Section Sets**

	Label	Shape	Type	Design List	Material	Design Rule	Area [in <sup>2</sup> ]	Iyy [in <sup>4</sup> ]	Izz [in <sup>4</sup> ]	J [in <sup>4</sup> ]
1	2.5" SCH 40 MOUNTING PIPE	PIPE 2.5	Column	Pipe	A53 Gr.B	Typical	1.61	1.45	1.45	2.89
2	HSS3X3 POST	HSS3X3X4	Column	SquareTube	A500 Gr.B Rect	Typical	2.44	3.02	3.02	5.08
3	HSS3X3 BEAM	HSS3X3X4	Beam	SquareTube	A500 Gr.B Rect	Typical	2.44	3.02	3.02	5.08
4	C8	C8X11.5	Beam	Channel	A36 Gr.36	Typical	3.37	1.31	32.5	0.13
5	C6	C6X13	Beam	Channel	A36 Gr.36	Typical	3.82	1.05	17.3	0.237
6	L3X3	L3X3X4	Beam	Single Angle	A36 Gr.36	Typical	1.44	1.23	1.23	0.031

**Hot Rolled Steel Design Parameters**

	Label	Shape	Length [in]	Lcomp top [in]	K y-y	K z-z	Function
1	P1	2.5" SCH 40 MOUNTING PIPE	96		2.1	2.1	Lateral
2	P2	2.5" SCH 40 MOUNTING PIPE	96		2.1	2.1	Lateral



Company : Herzog Engineering, LLC.  
 Designer : JJC  
 Job Number : 211426  
 Model Name : MIN Killebrew - Y Sector

9/17/2021  
 12:16:30 PM  
 Checked By : \_\_\_\_\_

### Hot Rolled Steel Design Parameters (Continued)

	Label	Shape	Length [in]	Lcomp top [in]	K y-y	K z-z	Function
3	P3	2.5" SCH 40 MOUNTING PIPE	96		2.1	2.1	Lateral
4	RRU	2.5" SCH 40 MOUNTING PIPE	96		2.1	2.1	Lateral
5	P5	2.5" SCH 40 MOUNTING PIPE	96		2.1	2.1	Lateral
6	M7	HSS3X3 BEAM	129	Lbyy	0.65	0.65	Lateral
7	M8	HSS3X3 BEAM	129	Lbyy	0.65	0.65	Lateral
8	M9	HSS3X3 BEAM	129	Lbyy	0.65	0.65	Lateral
9	M10	HSS3X3 BEAM	129	Lbyy	0.65	0.65	Lateral
10	M11	HSS3X3 BEAM	129	Lbyy	0.65	0.65	Lateral
11	M12	HSS3X3 POST	46	Lbyy	0.65	0.65	Lateral
12	M13	HSS3X3 POST	46	Lbyy	0.65	0.65	Lateral
13	M15	HSS3X3 POST	46	Lbyy	0.65	0.65	Lateral
14	M16	HSS3X3 POST	46	Lbyy	0.65	0.65	Lateral
15	M17	HSS3X3 POST	46	Lbyy	0.65	0.65	Lateral
16	M18	HSS3X3 POST	46	Lbyy	0.65	0.65	Lateral
17	M19	HSS3X3 POST	46	Lbyy	0.65	0.65	Lateral
18	M20	HSS3X3 POST	46	Lbyy	0.65	0.65	Lateral
19	M21	HSS3X3 POST	46	Lbyy	0.65	0.65	Lateral
20	M22	HSS3X3 POST	46	Lbyy	0.65	0.65	Lateral
21	M23	C8	18	Lbyy	0.65	0.65	Lateral
22	M24	C8	18	Lbyy	0.65	0.65	Lateral
23	M25	C8	18	Lbyy	0.65	0.65	Lateral
24	M26	C8	18	Lbyy	0.65	0.65	Lateral
25	M27	C8	18	Lbyy	0.65	0.65	Lateral
26	M28	C8	18	Lbyy	0.65	0.65	Lateral
27	M29	C8	18	Lbyy	0.65	0.65	Lateral
28	M30	C8	18	Lbyy	0.65	0.65	Lateral
29	M31	C8	18	Lbyy	0.65	0.65	Lateral
30	M32	C8	18	Lbyy	0.65	0.65	Lateral
31	M33	L3X3	132	Lbyy	0.65	0.65	Lateral
32	M34	L3X3	132	Lbyy	0.65	0.65	Lateral
33	M35	L3X3	132	Lbyy	0.65	0.65	Lateral
34	M36	L3X3	132	Lbyy	0.65	0.65	Lateral
35	M37	C6	132	Lbyy	0.65	0.65	Lateral
36	M38	C6	132	Lbyy	0.65	0.65	Lateral
37	M39	C6	132	Lbyy	0.65	0.65	Lateral
38	M40	C6	132	Lbyy	0.65	0.65	Lateral

### Hot Rolled Steel Properties

	Label	E [ksi]	G [ksi]	Nu	Therm. Coeff. [1e <sup>5</sup> °F <sup>-1</sup> ]	Density [k/ft <sup>3</sup> ]	Yield [ksi]	Ry	Fu [ksi]	Rt
1	A992	29000	11154	0.3	0.65	0.49	50	1.1	65	1.1
2	A36 Gr.36	29000	11154	0.3	0.65	0.49	36	1.5	58	1.2
3	A572 Gr.50	29000	11154	0.3	0.65	0.49	50	1.1	65	1.1
4	A500 Gr.B RND	29000	11154	0.3	0.65	0.527	42	1.4	58	1.3
5	A500 Gr.B Rect	29000	11154	0.3	0.65	0.527	46	1.4	58	1.3
6	A53 Gr.B	29000	11154	0.3	0.65	0.49	35	1.6	60	1.2
7	A1085	29000	11154	0.3	0.65	0.49	50	1.4	65	1.3
8	A913 Gr.65	29000	11154	0.3	0.65	0.49	65	1.1	80	1.1

### Basic Load Cases

	BLC Description	Category	Y Gravity	Nodal	Point	Distributed
1	DL Mount	DL	-1	22		
2	DL Equipment	DL			10	
3	Ice Load	OL1			10	34



Company : Herzog Engineering, LLC.  
 Designer : JJC  
 Job Number : 211426  
 Model Name : MIN Killebrew - Y Sector

9/17/2021  
 12:16:30 PM  
 Checked By : \_\_\_\_\_

**Basic Load Cases (Continued)**

	BLC Description	Category	Y Gravity	Nodal	Point	Distributed
4	WLx	WLX			10	19
5	WLz	WLZ			10	20
6	WLx on Ice	OL2			10	19
7	WLz on Ice	OL3			10	20

**Load Combinations**

	Description	Solve	P-Delta	BLC	Factor	BLC	Factor	BLC	Factor	BLC	Factor	BLC	Factor
1	1.4DL+1.4DLequip	Yes	Y	1	1.4	2	1.4						
2	1.2DL+1.2DLequip+1.0WL (0 deg)	Yes	Y	1	1.2	2	1.2	4	1				
3	1.2DL+1.2DLequip+1.0WL (30 deg)	Yes	Y	1	1.2	2	1.2	4	0.87	5	0.5		
4	1.2DL+1.2DLequip+1.0WL (60 deg)	Yes	Y	1	1.2	2	1.2	4	0.5	5	0.87		
5	1.2DL+1.2DLequip+1.0WL (90 deg)	Yes	Y	1	1.2	2	1.2	5	1				
6	1.2DL+1.2DLequip+1.0WL (120 deg)	Yes	Y	1	1.2	2	1.2	4	-0.5	5	0.87		
7	1.2DL+1.2DLequip+1.0WL (150 deg)	Yes	Y	1	1.2	2	1.2	4	-0.87	5	0.5		
8	1.2DL+1.2DLequip+1.0WL (180 deg)	Yes	Y	1	1.2	2	1.2	4	-1				
9	1.2DL+1.2DLequip+1.0WL (210 deg)	Yes	Y	1	1.2	2	1.2	4	-0.87	5	-0.5		
10	1.2DL+1.2DLequip+1.0WL (240 deg)	Yes	Y	1	1.2	2	1.2	4	-0.5	5	-0.87		
11	1.2DL+1.2DLequip+1.0WL (270 deg)	Yes	Y	1	1.2	2	1.2	5	-1				
12	1.2DL+1.2DLequip+1.0WL (300 deg)	Yes	Y	1	1.2	2	1.2	4	0.5	5	-0.87		
13	1.2DL+1.2DLequip+1.0WL (330 deg)	Yes	Y	1	1.2	2	1.2	4	0.87	5	-0.5		
14	0.9DL+0.9DLequip+1.0WL (0 deg)	Yes	Y	1	0.9	2	0.9	4	1				
15	0.9DL+0.9DLequip+1.0WL (30 deg)	Yes	Y	1	0.9	2	0.9	4	0.87	5	0.5		
16	0.9DL+0.9DLequip+1.0WL (60 deg)	Yes	Y	1	0.9	2	0.9	4	0.5	5	0.87		
17	0.9DL+0.9DLequip+1.0WL (90 deg)	Yes	Y	1	0.9	2	0.9	5	1				
18	0.9DL+0.9DLequip+1.0WL (120 deg)	Yes	Y	1	0.9	2	0.9	4	-0.5	5	0.87		
19	0.9DL+0.9DLequip+1.0WL (150 deg)	Yes	Y	1	0.9	2	0.9	4	-0.87	5	0.5		
20	0.9DL+0.9DLequip+1.0WL (180 deg)	Yes	Y	1	0.9	2	0.9	4	-1				
21	0.9DL+0.9DLequip+1.0WL (210 deg)	Yes	Y	1	0.9	2	0.9	4	-0.87	5	-0.5		
22	0.9DL+0.9DLequip+1.0WL (240 deg)	Yes	Y	1	0.9	2	0.9	4	-0.5	5	-0.87		
23	0.9DL+0.9DLequip+1.0WL (270 deg)	Yes	Y	1	0.9	2	0.9	5	-1				
24	0.9DL+0.9DLequip+1.0WL (300 deg)	Yes	Y	1	0.9	2	0.9	4	0.5	5	-0.87		
25	0.9DL+0.9DLequip+1.0WL (330 deg)	Yes	Y	1	0.9	2	0.9	4	0.87	5	-0.5		
26	1.2DL+1.2DLequip+1.0Ice+1.0WLice (0 deg)	Yes	Y	1	1.2	2	1.2	3	1	6	1		
27	1.2DL+1.2DLequip+1.0Ice+1.0WLice (30 deg)	Yes	Y	1	1.2	2	1.2	3	1	6	0.87	7	0.5
28	1.2DL+1.2DLequip+1.0Ice+1.0WLice (60 deg)	Yes	Y	1	1.2	2	1.2	3	1	6	0.5	7	0.87
29	1.2DL+1.2DLequip+1.0Ice+1.0WLice (90 deg)	Yes	Y	1	1.2	2	1.2	3	1	7	1		
30	1.2DL+1.2DLequip+1.0Ice+1.0WLice (120 deg)	Yes	Y	1	1.2	2	1.2	3	1	6	-0.5	7	0.87
31	1.2DL+1.2DLequip+1.0Ice+1.0WLice (150 deg)	Yes	Y	1	1.2	2	1.2	3	1	6	-0.87	7	0.5
32	1.2DL+1.2DLequip+1.0Ice+1.0WLice (180 deg)	Yes	Y	1	1.2	2	1.2	3	1	6	-1		
33	1.2DL+1.2DLequip+1.0Ice+1.0WLice (210 deg)	Yes	Y	1	1.2	2	1.2	3	1	6	-0.87	7	-0.5
34	1.2DL+1.2DLequip+1.0Ice+1.0WLice (240 deg)	Yes	Y	1	1.2	2	1.2	3	1	6	-0.5	7	-0.87
35	1.2DL+1.2DLequip+1.0Ice+1.0WLice (270 deg)	Yes	Y	1	1.2	2	1.2	3	1	7	-1		
36	1.2DL+1.2DLequip+1.0Ice+1.0WLice (300 deg)	Yes	Y	1	1.2	2	1.2	3	1	6	0.5	7	-0.87
37	1.2DL+1.2DLequip+1.0Ice+1.0WLice (330 deg)	Yes	Y	1	1.2	2	1.2	3	1	6	0.87	7	-0.5
38	DL+DLequip		Y	1	1	2	1						
39	DL+DLequip+0.6WL (0 deg)		Y	1	1	2	1	4	0.6				
40	DL+DLequip+0.6WL (90 deg)		Y	1	1	2	1	5	0.6				
41	DL+DLequip+0.75(0.6WL (0 deg))		Y	1	1	2	1	4	0.45				
42	DL+DLequip+0.75(0.6WL (90 deg))		Y	1	1	2	1	5	0.45				
43	0.6DL+0.6DLequip+0.6WL (0 deg)		Y	1	0.6	2	0.6	4	0.6				
44	0.6DL+0.6DLequip+0.6WL (90 deg)		Y	1	0.6	2	0.6	5	0.6				
45	0.6DL+0.6DLequip		Y	1	0.6	2	0.6						
46	DL+DLequip+0.7Ice		Y	1	1	2	1	3	0.7				
47	DL+DLequip+0.7Ice+0.7WLice (0 deg)		Y	1	1	2	1	3	0.7	6	0.7		
48	DL+DLequip+0.7Ice+0.7WLice (90 deg)		Y	1	1	2	1	3	0.7	7	0.7		



Company : Herzog Engineering, LLC.  
 Designer : JJC  
 Job Number : 211426  
 Model Name : MIN Killebrew - Y Sector

9/17/2021  
 12:16:30 PM  
 Checked By : \_\_\_\_\_

**Load Combinations (Continued)**

Description		Solve	P-Delta	BLC Factor	BLC Factor	BLC Factor	BLC Factor	BLC Factor	BLC Factor		
49	0.6DL+0.6DL <sub>equip</sub> +0.7l <sub>ce</sub> +0.7W <sub>Lice</sub> (0 deg)		Y	1	0.6	2	0.6	3	0.7	6	0.7
50	0.6DL+0.6DL <sub>equip</sub> +0.7l <sub>ce</sub> +0.7W <sub>Lice</sub> (90 deg)		Y	1	0.6	2	0.6	3	0.7	7	0.7

**Envelope AISC 15TH (360-16): LRFD Member Steel Code Checks**

Member	Shape	Code	Check	Loc[in]	LC	Shear	Check	Loc[in]	Dir	L <sub>c</sub>	Pnc [lb]	phi*Pnt [lb]	phi*Mn y-y [k-ft]	phi*Mn z-z [k-ft]	Cb	Eqn
1	P1	PIPE 2.5	0.331	86	20		0.012	86		20	8059.847	50715	3.596	3.596	1.613	H1-1b
2	P2	PIPE 2.5	0.331	86	20		0.012	86		20	8059.847	50715	3.596	3.596	1.613	H1-1b
3	P3	PIPE 2.5	0.128	86	11		0.009	86		23	8059.847	50715	3.596	3.596	1.547	H1-1b
4	RRU	PIPE 2.5	0.241	86	8		0.013	86		20	8059.847	50715	3.596	3.596	1.966	H1-1b
5	P5	PIPE 2.5	0.172	86	8		0.011	86		20	8059.847	50715	3.596	3.596	2.3	H1-1b
6	M7	HSS3X3X4	0.189	34.938	3		0.108	34.938	z	23	68934.827	101016	8.556	8.556	2.094	H1-1b
7	M8	HSS3X3X4	0.223	34.938	28		0.112	34.938	z	23	68934.827	101016	8.556	8.556	2.035	H1-1b
8	M9	HSS3X3X4	0.154	34.938	28		0.069	34.938	y	11	68934.827	101016	8.556	8.556	2.031	H1-1b
9	M10	HSS3X3X4	0.223	34.938	28		0.112	34.938	z	17	68934.827	101016	8.556	8.556	2.047	H1-1b
10	M11	HSS3X3X4	0.163	34.938	28		0.081	34.938	z	17	68934.827	101016	8.556	8.556	2.013	H1-1b
11	M12	HSS3X3X4	0.041	29.708	29		0.012	30.188	y	3	96225.122	101016	8.556	8.556	2.321	H1-1b
12	M13	HSS3X3X4	0.039	29.708	33		0.01	30.188	y	3	96225.122	101016	8.556	8.556	2.424	H1-1b
13	M15	HSS3X3X4	0.033	29.708	33		0.008	23.479	y	9	96225.122	101016	8.556	8.556	2.414	H1-1b
14	M16	HSS3X3X4	0.038	29.708	31		0.009	23.479	y	34	96225.122	101016	8.556	8.556	2.422	H1-1b
15	M17	HSS3X3X4	0.037	29.708	34		0.011	30.188	y	13	96225.122	101016	8.556	8.556	2.408	H1-1b
16	M18	HSS3X3X4	0.136	29.708	3		0.039	9.104	z	5	96225.122	101016	8.556	8.556	1.886	H1-1b
17	M19	HSS3X3X4	0.154	29.708	13		0.047	9.104	z	11	96225.122	101016	8.556	8.556	1.911	H1-1b
18	M20	HSS3X3X4	0.108	29.708	3		0.025	9.104	z	5	96225.122	101016	8.556	8.556	1.918	H1-1b
19	M21	HSS3X3X4	0.154	29.708	3		0.047	9.104	z	5	96225.122	101016	8.556	8.556	1.908	H1-1b
20	M22	HSS3X3X4	0.113	29.708	13		0.033	9.104	z	11	96225.122	101016	8.556	8.556	1.899	H1-1b
21	M23	C8X11.5	0.052	9	31		0.009	9.562	z	9	105227.221	109188	3.353	26.001	1.343	H1-1b
22	M24	C8X11.5	0.054	9	32		0.009	9.562	z	9	105227.221	109188	3.353	26.001	1.335	H1-1b
23	M25	C8X11.5	0.053	9	32		0.007	18	z	31	105227.221	109188	3.353	26.001	1.382	H1-1b
24	M26	C8X11.5	0.054	9	32		0.009	9.562	z	6	105227.221	109188	3.353	26.001	1.362	H1-1b
25	M27	C8X11.5	0.051	9	33		0.009	11.062	z	30	105227.221	109188	3.353	26.001	1.352	H1-1b
26	M28	C8X11.5	0.13	9	33		0.021	10.125	z	34	105227.221	109188	3.353	26.001	1.387	H1-1b
27	M29	C8X11.5	0.131	9	33		0.022	9.938	z	34	105227.221	109188	3.353	26.001	1.38	H1-1b
28	M30	C8X11.5	0.133	9	31		0.02	10.312	z	29	105227.221	109188	3.353	26.001	1.332	H1-1b
29	M31	C8X11.5	0.129	9	31		0.022	9.938	z	30	105227.221	109188	3.353	26.001	1.386	H1-1b
30	M32	C8X11.5	0.125	9	31		0.02	10.312	z	30	105227.221	109188	3.353	26.001	1.372	H1-1b
31	M33	L3X3X4	0.008	0	2		0.002	0	y	3	15123.054	46656	1.688	2.892	1.5	H2-1
32	M34	L3X3X4	0.009	132	10		0.002	103.125	y	3	15123.054	46656	1.688	2.892	1.5	H2-1
33	M35	L3X3X4	0.018	101.75	6		0.003	103.125	y	8	15123.054	46656	1.688	2.883	1.486	H2-1
34	M36	L3X3X4	0.02	0	6		0.003	0	y	7	15123.054	46656	1.688	2.892	1.5	H2-1
35	M37	C6X13	0.015	0	10		0.004	28.875	z	3	32222.154	123768	2.756	19.191	1.35	H1-1b
36	M38	C6X13	0.025	0	3		0.003	126.5	z	8	32222.154	123768	2.756	18.733	1.318	H1-1b
37	M39	C6X13	0.047	0	17		0.007	23.375	y	10	32222.154	123768	2.756	18.136	1.276	H1-1b
38	M40	C6X13	0.05	0	12		0.007	30.25	z	7	32222.154	123768	2.756	19.683	2.491	H1-1b

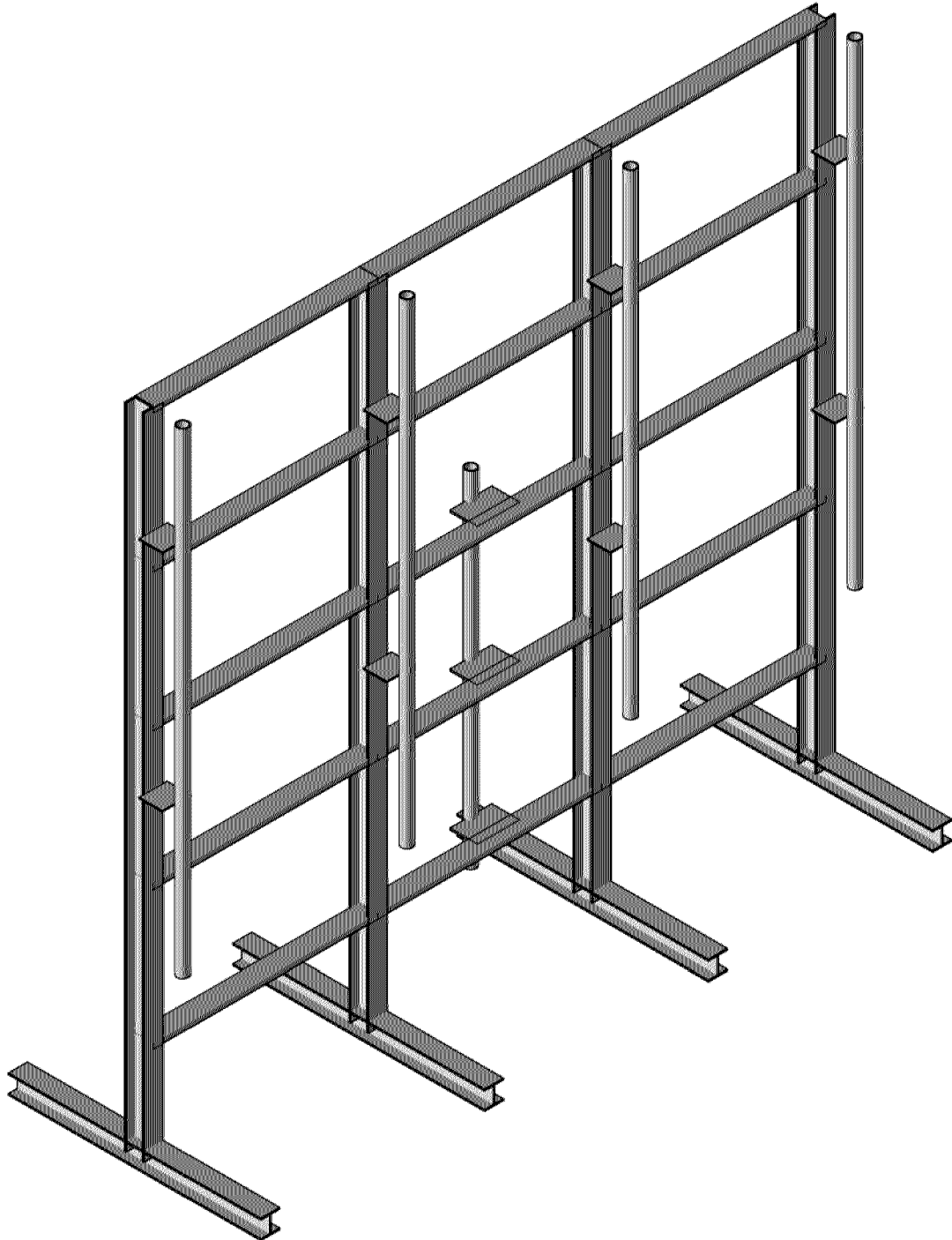
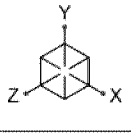

Envelope Only Solution

Herzog Engineering, LLC.

JJC

211426

MIN Killebrew - Z Sector

3D VIEW - 1

Sep 17, 2021

211426 MIN Killebrew Z Sector.r3d

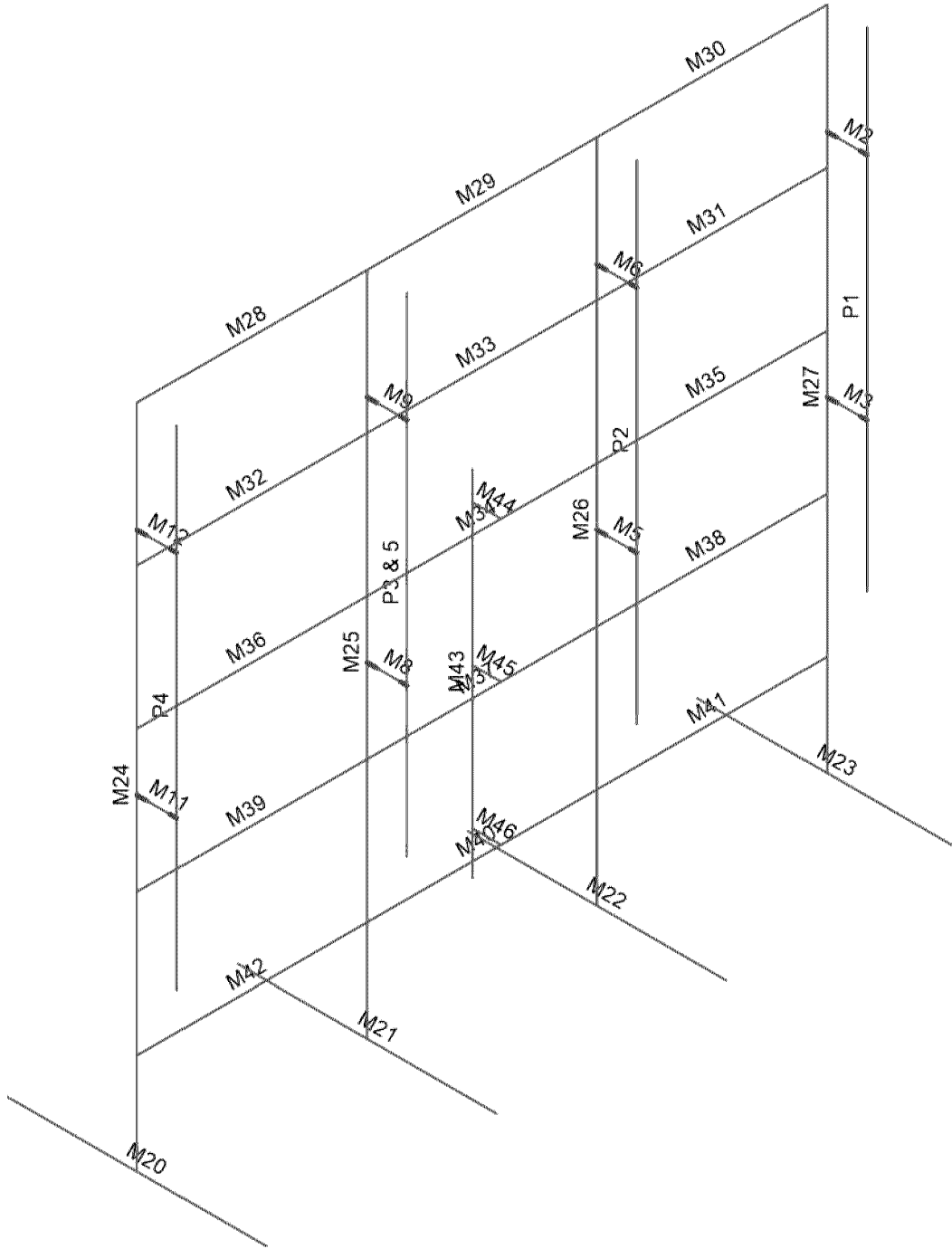
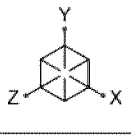

Envelope Only Solution

Herzog Engineering, LLC.

JJC

211426

MIN Killebrew - Z Sector

MEMBER LABELS - 2

Sep 17, 2021

211426 MIN Killebrew Z Sector.r3d

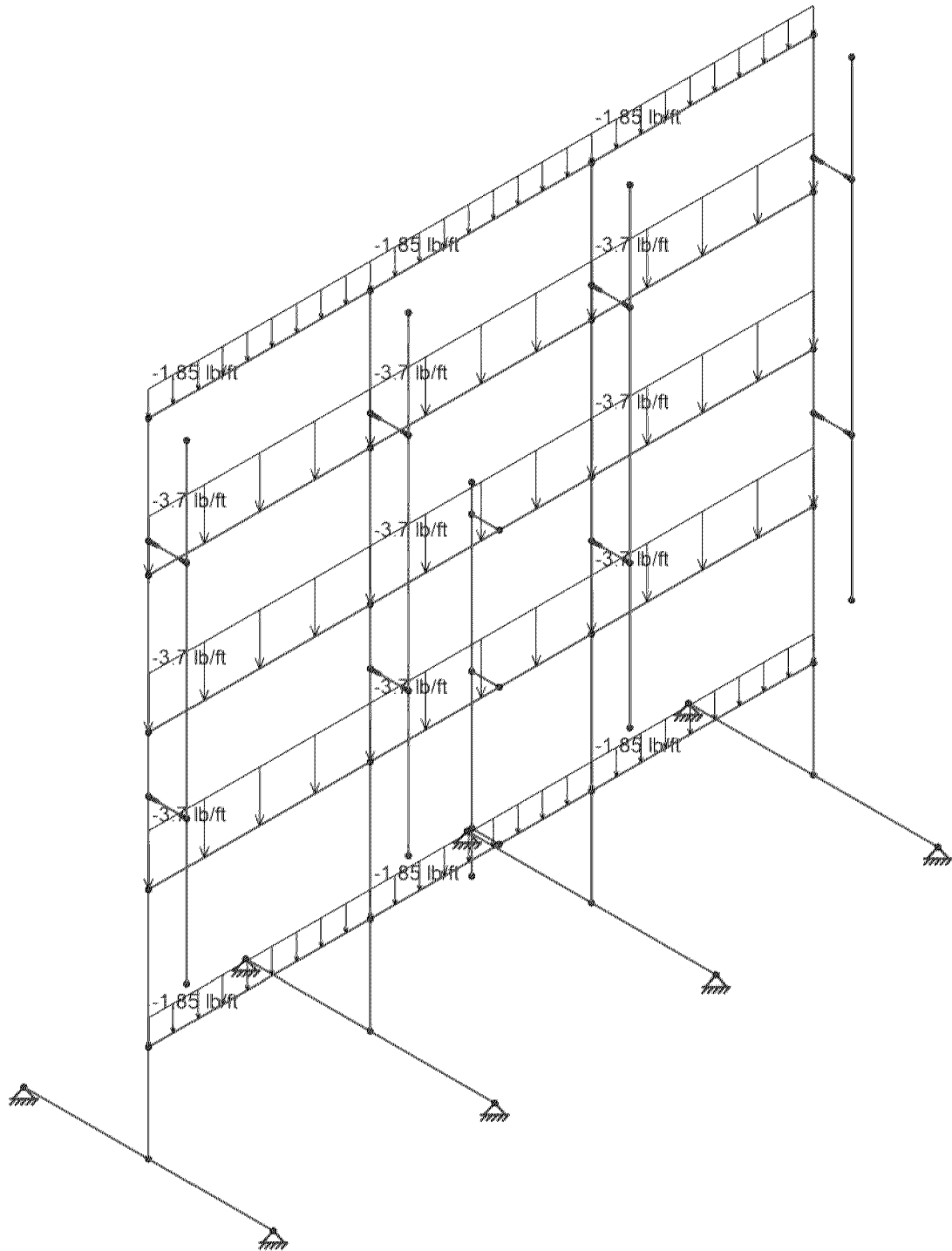
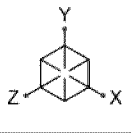

Loads: BLC 1, DL Mount  
Envelope Only Solution

Herzog Engineering, LLC.

JJC

211426

MIN Killebrew - Z Sector

DL MOUNT - 3

Sep 17, 2021

211426 MIN Killebrew Z Sector.r3d

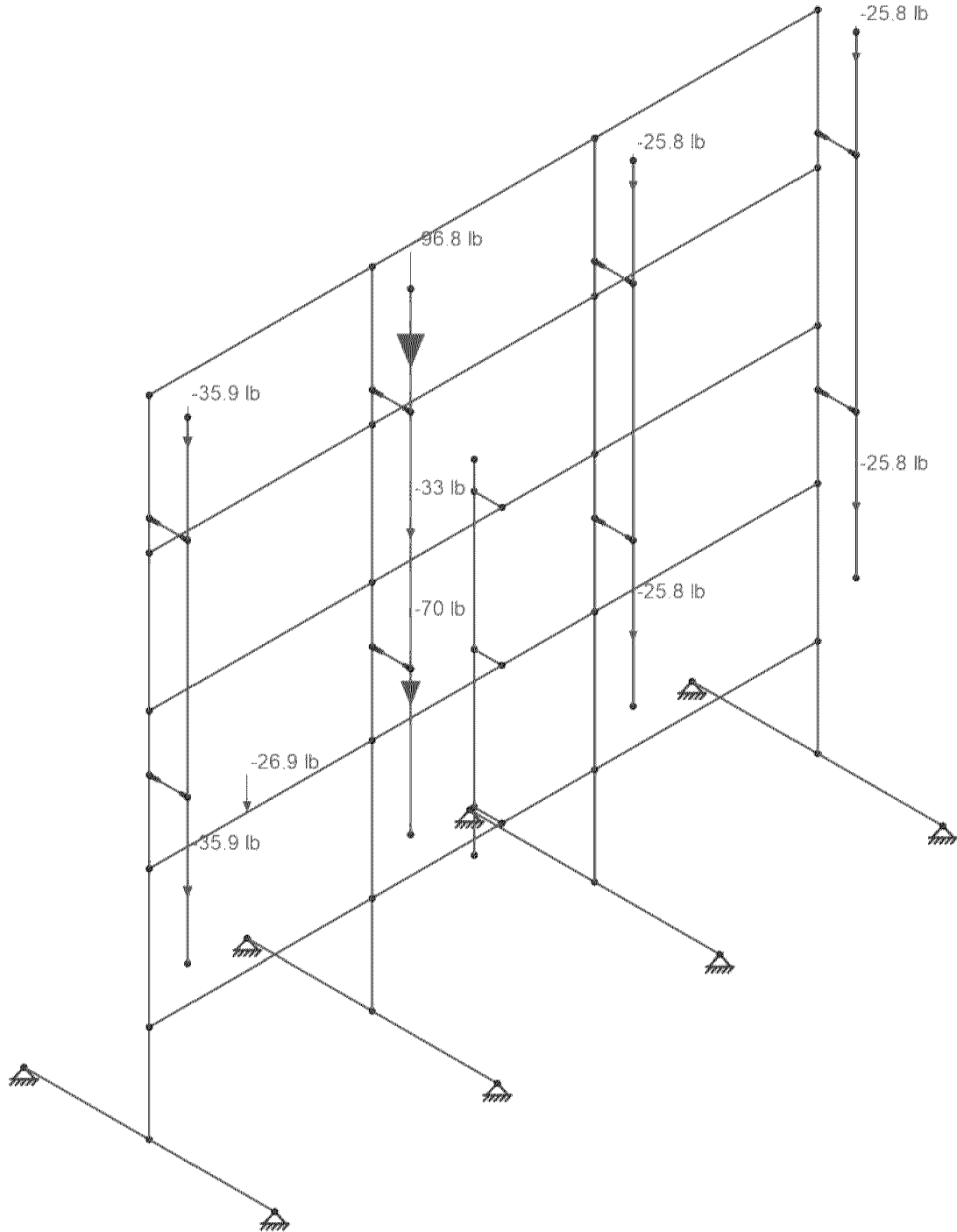
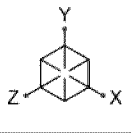

Loads: BLC 2, DL Equipment  
Envelope Only Solution

Herzog Engineering, LLC.

JJC

211426

MIN Killebrew - Z Sector

DL EQUIPMENT - 4

Sep 17, 2021

211426 MIN Killebrew Z Sector.r3d

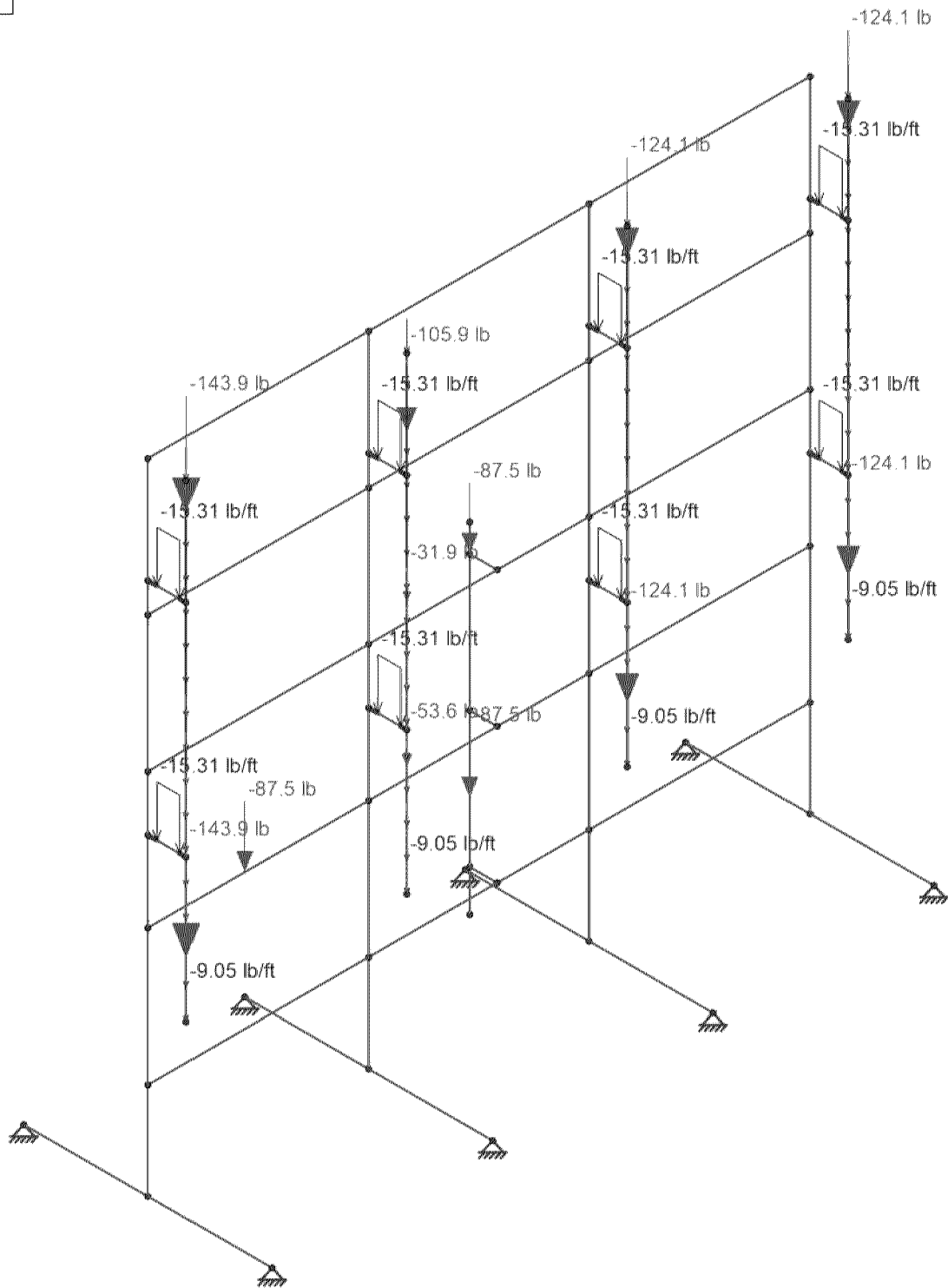
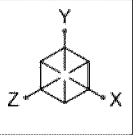

Loads: BLC 3, Ice Load  
Envelope Only Solution

Herzog Engineering, LLC.

JJC

211426

MIN Killebrew - Z Sector

ICE LOAD - 5

Sep 17, 2021

211426 MIN Killebrew Z Sector.r3d

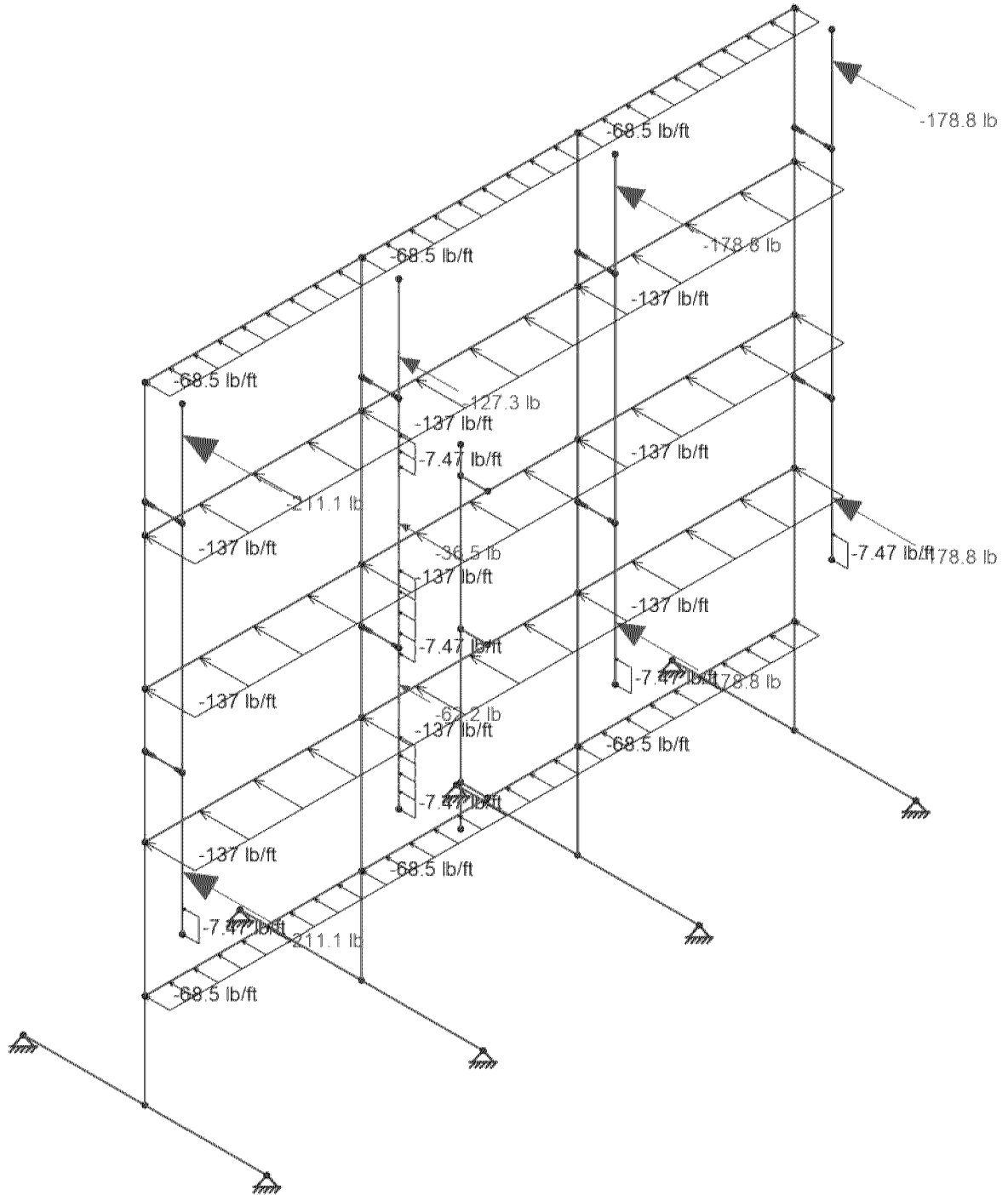
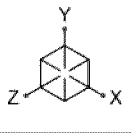

Loads: BLC 4, WLx  
Envelope Only Solution

Herzog Engineering, LLC.

JJC

211426

MIN Killebrew - Z Sector

WIND LOAD (+X) - 6

Sep 17, 2021

211426 MIN Killebrew Z Sector.r3d

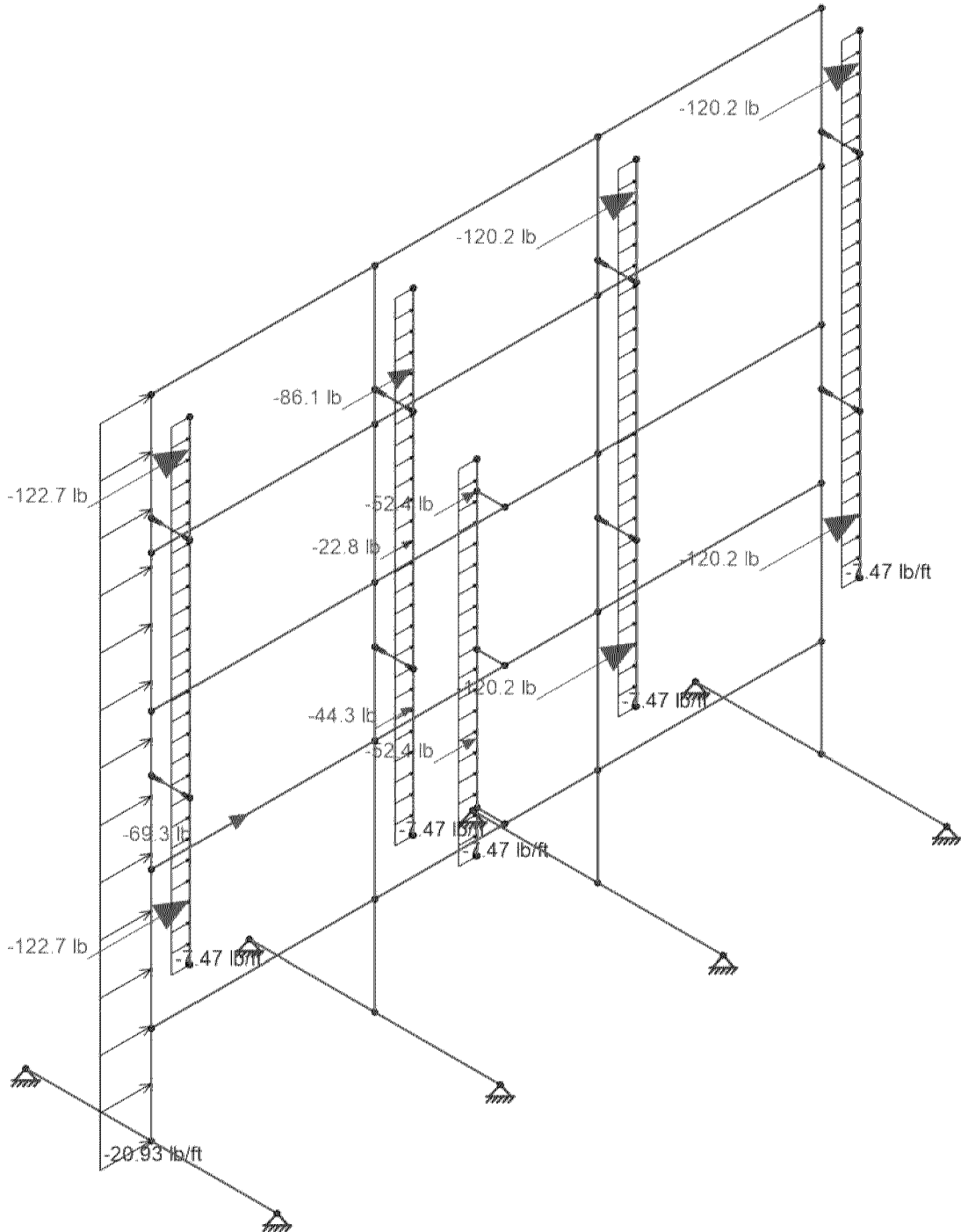
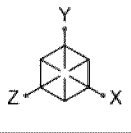

Loads: BLC 5, WLz  
Envelope Only Solution

Herzog Engineering, LLC.

JJC

211426

MIN Killebrew - Z Sector

WIND LOAD (+Z) - 7

Sep 17, 2021

211426 MIN Killebrew Z Sector.r3d

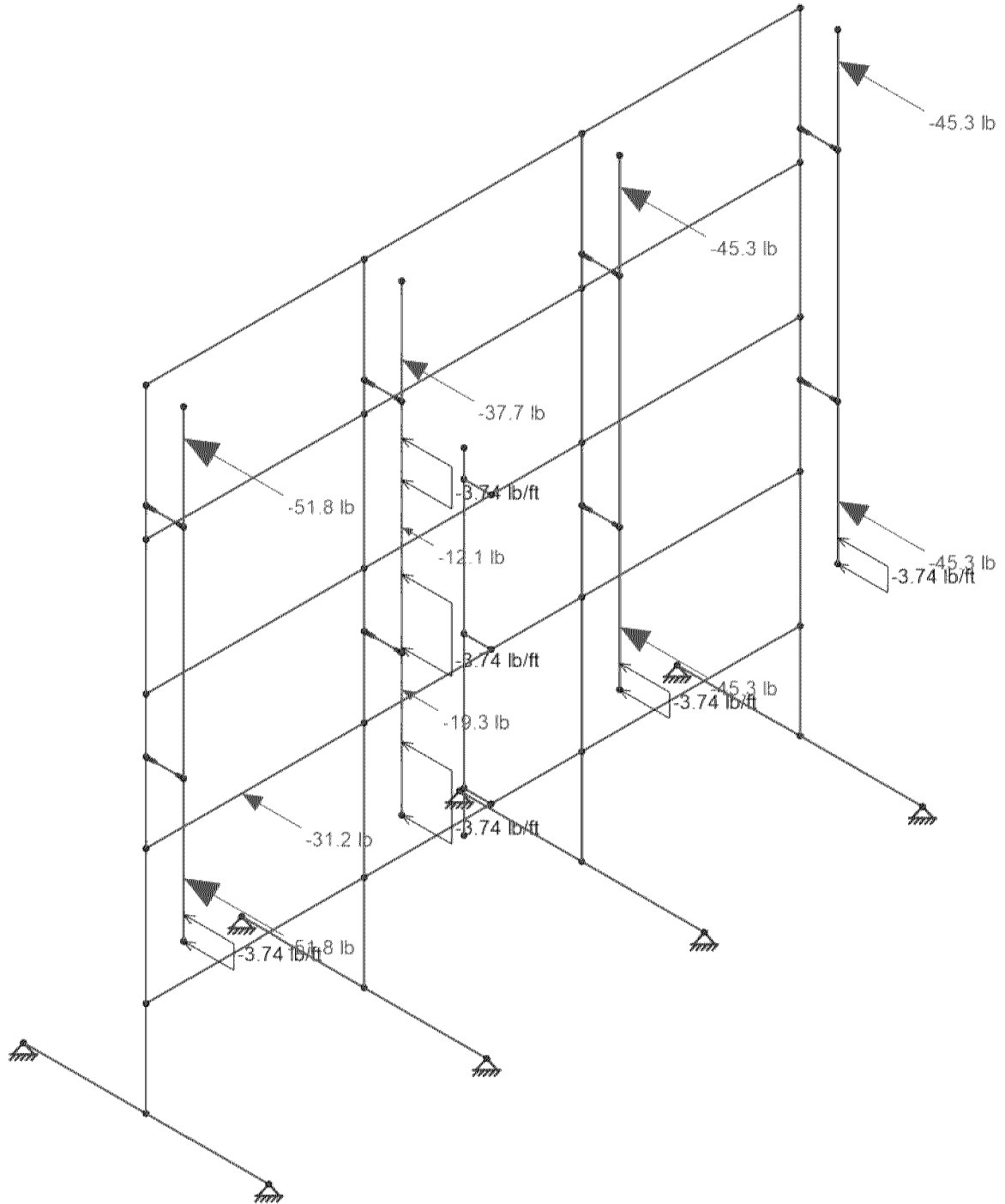
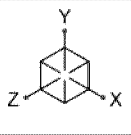

Loads: BLC 6, WLx on Ice Envelope Only Solution

Herzog Engineering, LLC.

JJC

211426

MIN Killebrew - Z Sector

WIND ON ICE (+X) - 8

Sep 17, 2021

211426 MIN Killebrew Z Sector.r3d

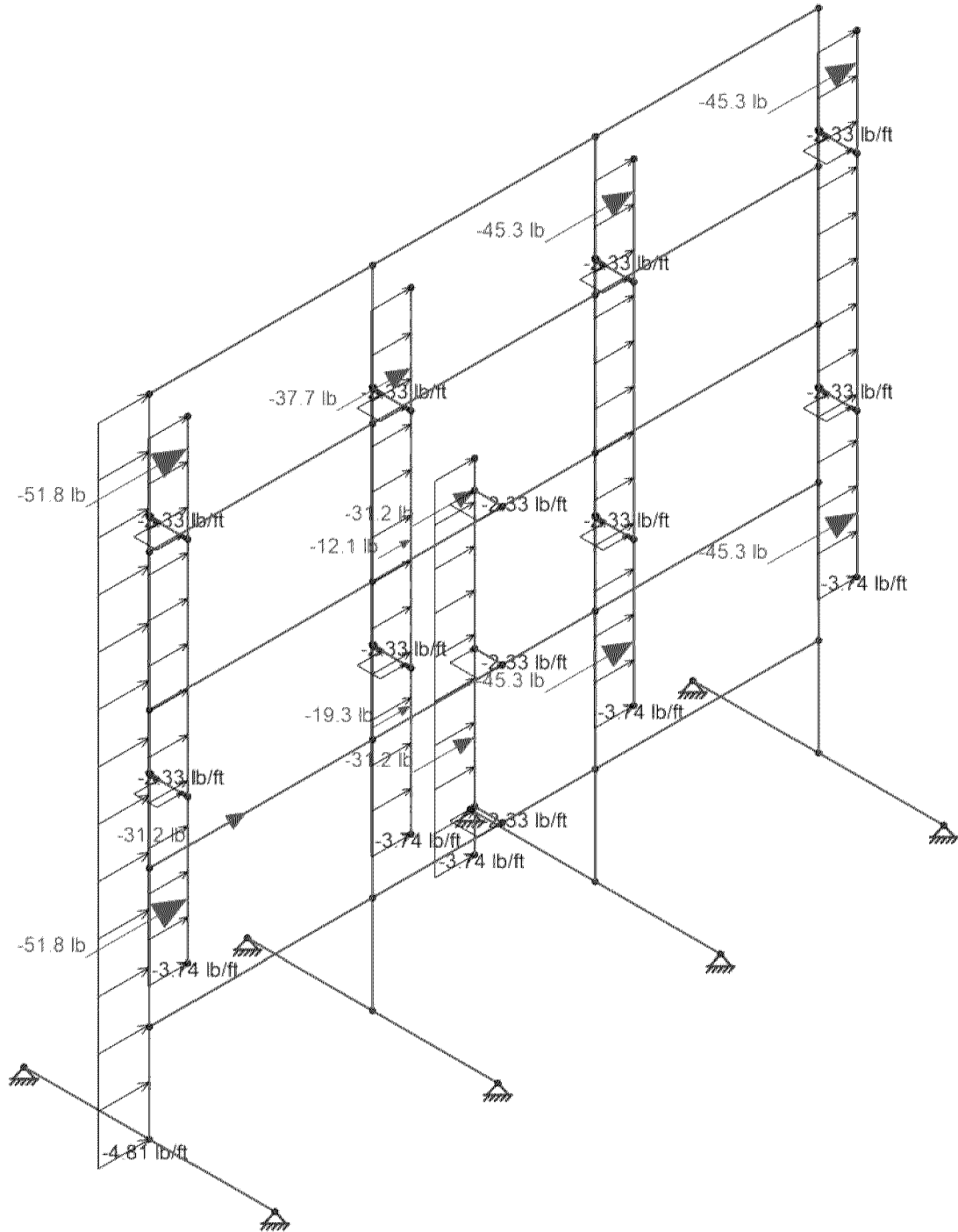
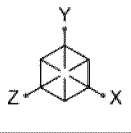

Loads: BLC 7, WLz on Ice Envelope Only Solution

Herzog Engineering, LLC.

JJC

211426

MIN Killebrew - Z Sector

WIND ON ICE (+Z) - 9

Sep 17, 2021

211426 MIN Killebrew Z Sector.r3d



Company : Herzog Engineering, LLC.  
 Designer : JJC  
 Job Number : 211426  
 Model Name : MIN Killebrew - Z Sector

9/17/2021  
 12:09:11 PM  
 Checked By : \_\_\_\_\_

**Member Primary Data**

	Label	I Node	J Node	Rotate(deg)	Section/Shape	Type	Design List	Material	Design Rule
1	P1	N3	N2		2" SCH 40 MOUNTING PIPE	Column	Pipe	A53 Gr.B	Typical
2	M2	N4	N1	90	L3x3x1/4 BRACKET	Beam	RECT	A36 Gr.36	Typical
3	M3	N6	N5	90	L3x3x1/4 BRACKET	Beam	RECT	A36 Gr.36	Typical
4	P2	N9	N12		2" SCH 40 MOUNTING PIPE	Column	Pipe	A53 Gr.B	Typical
5	M5	N14	N10	90	L3x3x1/4 BRACKET	Beam	RECT	A36 Gr.36	Typical
6	M6	N15	N11	90	L3x3x1/4 BRACKET	Beam	RECT	A36 Gr.36	Typical
7	P3 & 5	N16	N19		2" SCH 40 MOUNTING PIPE	Column	Pipe	A53 Gr.B	Typical
8	M8	N20	N17	90	L3x3x1/4 BRACKET	Beam	RECT	A36 Gr.36	Typical
9	M9	N21	N18	90	L3x3x1/4 BRACKET	Beam	RECT	A36 Gr.36	Typical
10	P4	N22	N25		2" SCH 40 MOUNTING PIPE	Column	Pipe	A53 Gr.B	Typical
11	M11	N26	N23	90	L3x3x1/4 BRACKET	Beam	RECT	A36 Gr.36	Typical
12	M12	N27	N24	90	L3x3x1/4 BRACKET	Beam	RECT	A36 Gr.36	Typical
13	M20	N58	N54		W4 base	Beam	Wide Flange	A36 Gr.36	Typical
14	M21	N56	N52		W4 base	Beam	Wide Flange	A36 Gr.36	Typical
15	M22	N57	N53		W4 base	Beam	Wide Flange	A36 Gr.36	Typical
16	M23	N59	N55		W4 base	Beam	Wide Flange	A36 Gr.36	Typical
17	M24	N50	N40		W4 posts	Column	Wide Flange	A36 Gr.36	Typical
18	M25	N49	N41		W4 posts	Column	Wide Flange	A36 Gr.36	Typical
19	M26	N48	N42		W4 posts	Column	Wide Flange	A36 Gr.36	Typical
20	M27	N51	N43		W4 posts	Column	Wide Flange	A36 Gr.36	Typical
21	M28	N40	N41	90	Wall Channel	Beam	None	A653 SS Gr33	Typical
22	M29	N41	N42	90	Wall Channel	Beam	None	A653 SS Gr33	Typical
23	M30	N42	N43	90	Wall Channel	Beam	None	A653 SS Gr33	Typical
24	M31	N60	N61	90	Wall Channel	Beam	None	A653 SS Gr33	Typical
25	M32	N62	N63	90	Wall Channel	Beam	None	A653 SS Gr33	Typical
26	M33	N63	N60	90	Wall Channel	Beam	None	A653 SS Gr33	Typical
27	M34	N64	N65	90	Wall Channel	Beam	None	A653 SS Gr33	Typical
28	M35	N65	N66	90	Wall Channel	Beam	None	A653 SS Gr33	Typical
29	M36	N67	N64	90	Wall Channel	Beam	None	A653 SS Gr33	Typical
30	M37	N68	N69	90	Wall Channel	Beam	None	A653 SS Gr33	Typical
31	M38	N69	N70	90	Wall Channel	Beam	None	A653 SS Gr33	Typical
32	M39	N71	N68	90	Wall Channel	Beam	None	A653 SS Gr33	Typical
33	M40	N44	N46	90	Wall Channel	Beam	None	A653 SS Gr33	Typical
34	M41	N46	N47	90	Wall Channel	Beam	None	A653 SS Gr33	Typical
35	M42	N45	N44	90	Wall Channel	Beam	None	A653 SS Gr33	Typical
36	M43	N78	N79	90	2" SCH 40 MOUNTING PIPE	Column	Pipe	A53 Gr.B	Typical
37	M44	N72	N76	90	BRACKET	Beam	RECT	A36 Gr.36	Typical
38	M45	N74	N75	90	BRACKET	Beam	RECT	A36 Gr.36	Typical
39	M46	N73	N77	90	BRACKET	Beam	RECT	A36 Gr.36	Typical

**Hot Rolled Steel Section Sets**

	Label	Shape	Type	Design List	Material	Design Rule	Area [in <sup>2</sup> ]	Iyy [in <sup>4</sup> ]	Izz [in <sup>4</sup> ]	J [in <sup>4</sup> ]
1	BRACKET	PL3/8x9	Beam	RECT	A36 Gr.36	Typical	3.375	0.04	22.781	0.154
2	L3x3x1/4 BRACKET	PL6x0.25	Beam	RECT	A36 Gr.36	Typical	1.5	0.008	4.5	0.03
3	2" SCH 40 MOUNTING PIPE	PIPE 2.0	Column	Pipe	A53 Gr.B	Typical	1.02	0.627	0.627	1.25
4	HSS	HSS6X4X4	Beam	SquareTube	A500 Gr.B Rect	Typical	4.3	11.1	20.9	23.6
5	W4 base	W4X13	Beam	Wide Flange	A36 Gr.36	Typical	3.83	3.86	11.3	0.151
6	W4 posts	W4X13	Column	Wide Flange	A36 Gr.36	Typical	3.83	3.86	11.3	0.151



Company : Herzog Engineering, LLC.  
 Designer : JJC  
 Job Number : 211426  
 Model Name : MIN Killebrew - Z Sector

9/17/2021  
 12:09:11 PM  
 Checked By : \_\_\_\_\_

**Hot Rolled Steel Design Parameters**

	Label	Shape	Length [in]	Lcomp top [in]	K y-y	K z-z	Function
1	P1	2" SCH 40 MOUNTING PIPE	102		2.1	2.1	Lateral
2	M2	L3x3x1/4 BRACKET	8.3		0.65	0.65	Lateral
3	M3	L3x3x1/4 BRACKET	8.3		0.65	0.65	Lateral
4	P2	2" SCH 40 MOUNTING PIPE	102		2.1	2.1	Lateral
5	M5	L3x3x1/4 BRACKET	8.3		0.65	0.65	Lateral
6	M6	L3x3x1/4 BRACKET	8.3		0.65	0.65	Lateral
7	P3 & 5	2" SCH 40 MOUNTING PIPE	102		2.1	2.1	Lateral
8	M8	L3x3x1/4 BRACKET	8.3		0.65	0.65	Lateral
9	M9	L3x3x1/4 BRACKET	8.3		0.65	0.65	Lateral
10	P4	2" SCH 40 MOUNTING PIPE	102		2.1	2.1	Lateral
11	M11	L3x3x1/4 BRACKET	8.3		0.65	0.65	Lateral
12	M12	L3x3x1/4 BRACKET	8.3		0.65	0.65	Lateral
13	M20	W4 base	54	Lbyy	1	1	Lateral
14	M21	W4 base	54	Lbyy	1	1	Lateral
15	M22	W4 base	54	Lbyy	1	1	Lateral
16	M23	W4 base	54	Lbyy	1	1	Lateral
17	M24	W4 posts	139	Lbyy	0.65	0.65	Lateral
18	M25	W4 posts	139	Lbyy	0.65	0.65	Lateral
19	M26	W4 posts	139	Lbyy	0.65	0.65	Lateral
20	M27	W4 posts	139	Lbyy	0.65	0.65	Lateral
21	M43	2" SCH 40 MOUNTING PIPE	74	Lbyy	2.1	2.1	Lateral
22	M44	BRACKET	6	Lbyy	0.65	0.65	Lateral
23	M45	BRACKET	6	Lbyy	0.65	0.65	Lateral
24	M46	BRACKET	6	Lbyy	0.65	0.65	Lateral

**Hot Rolled Steel Properties**

	Label	E [ksi]	G [ksi]	Nu	Therm. Coeff. [1e <sup>-5</sup> F <sup>-1</sup> ]	Density [k/ft <sup>3</sup> ]	Yield [ksi]	Ry	Fu [ksi]	Rt
1	A992	29000	11154	0.3	0.65	0.49	50	1.1	65	1.1
2	A36 Gr.36	29000	11154	0.3	0.65	0.49	36	1.5	58	1.2
3	A572 Gr.50	29000	11154	0.3	0.65	0.49	50	1.1	65	1.1
4	A500 Gr.B RND	29000	11154	0.3	0.65	0.527	42	1.4	58	1.3
5	A500 Gr.B Rect	29000	11154	0.3	0.65	0.527	46	1.4	58	1.3
6	A53 Gr.B	29000	11154	0.3	0.65	0.49	35	1.6	60	1.2
7	A1085	29000	11154	0.3	0.65	0.49	50	1.4	65	1.3
8	A913 Gr.65	29000	11154	0.3	0.65	0.49	65	1.1	80	1.1

**Basic Load Cases**

	BLC Description	Category	Y Gravity	Point	Distributed
1	DL Mount	DL	-1		15
2	DL Equipment	DL		10	
3	Ice Load	OL1		12	12
4	WLx	WLX		9	21
5	WLz	WLZ		12	6
6	WLx on Ice	OL2		10	6
7	WLz on Ice	OL3		12	17

**Load Combinations**

	Description	Solve P-Delta	BLC Factor	BLC Factor	BLC Factor	BLC Factor	BLC Factor	BLC Factor	BLC Factor
1	1.4DL+1.4DLequip	Yes	Y	1	1.4	2	1.4		
2	1.2DL+1.2DLequip+1.0WL (0 deg)	Yes	Y	1	1.2	2	1.2	4	1
3	1.2DL+1.2DLequip+1.0WL (30 deg)	Yes	Y	1	1.2	2	1.2	4	0.87
								5	0.5



Company : Herzog Engineering, LLC.  
 Designer : JJC  
 Job Number : 211426  
 Model Name : MIN Killebrew - Z Sector

9/17/2021  
 12:09:11 PM  
 Checked By : \_\_\_\_\_

**Load Combinations (Continued)**

	Description	Solve	P-Delta	BLC	Factor	BLC	Factor	BLC	Factor	BLC	Factor	BLC	Factor
4	1.2DL+1.2DLequip+1.0WL (60 deg)	Yes	Y	1	1.2	2	1.2	4	0.5	5	0.87		
5	1.2DL+1.2DLequip+1.0WL (90 deg)	Yes	Y	1	1.2	2	1.2	5	1				
6	1.2DL+1.2DLequip+1.0WL (120 deg)	Yes	Y	1	1.2	2	1.2	4	-0.5	5	0.87		
7	1.2DL+1.2DLequip+1.0WL (150 deg)	Yes	Y	1	1.2	2	1.2	4	-0.87	5	0.5		
8	1.2DL+1.2DLequip+1.0WL (180 deg)	Yes	Y	1	1.2	2	1.2	4	-1				
9	1.2DL+1.2DLequip+1.0WL (210 deg)	Yes	Y	1	1.2	2	1.2	4	-0.87	5	-0.5		
10	1.2DL+1.2DLequip+1.0WL (240 deg)	Yes	Y	1	1.2	2	1.2	4	-0.5	5	-0.87		
11	1.2DL+1.2DLequip+1.0WL (270 deg)	Yes	Y	1	1.2	2	1.2	5	-1				
12	1.2DL+1.2DLequip+1.0WL (300 deg)	Yes	Y	1	1.2	2	1.2	4	0.5	5	-0.87		
13	1.2DL+1.2DLequip+1.0WL (330 deg)	Yes	Y	1	1.2	2	1.2	4	0.87	5	-0.5		
14	0.9DL+0.9DLequip+1.0WL (0 deg)	Yes	Y	1	0.9	2	0.9	4	1				
15	0.9DL+0.9DLequip+1.0WL (30 deg)	Yes	Y	1	0.9	2	0.9	4	0.87	5	0.5		
16	0.9DL+0.9DLequip+1.0WL (60 deg)	Yes	Y	1	0.9	2	0.9	4	0.5	5	0.87		
17	0.9DL+0.9DLequip+1.0WL (90 deg)	Yes	Y	1	0.9	2	0.9	5	1				
18	0.9DL+0.9DLequip+1.0WL (120 deg)	Yes	Y	1	0.9	2	0.9	4	-0.5	5	0.87		
19	0.9DL+0.9DLequip+1.0WL (150 deg)	Yes	Y	1	0.9	2	0.9	4	-0.87	5	0.5		
20	0.9DL+0.9DLequip+1.0WL (180 deg)	Yes	Y	1	0.9	2	0.9	4	-1				
21	0.9DL+0.9DLequip+1.0WL (210 deg)	Yes	Y	1	0.9	2	0.9	4	-0.87	5	-0.5		
22	0.9DL+0.9DLequip+1.0WL (240 deg)	Yes	Y	1	0.9	2	0.9	4	-0.5	5	-0.87		
23	0.9DL+0.9DLequip+1.0WL (270 deg)	Yes	Y	1	0.9	2	0.9	5	-1				
24	0.9DL+0.9DLequip+1.0WL (300 deg)	Yes	Y	1	0.9	2	0.9	4	0.5	5	-0.87		
25	0.9DL+0.9DLequip+1.0WL (330 deg)	Yes	Y	1	0.9	2	0.9	4	0.87	5	-0.5		
26	1.2DL+1.2DLequip+1.0Ice+1.0WLice (0 deg)	Yes	Y	1	1.2	2	1.2	3	1	6	1		
27	1.2DL+1.2DLequip+1.0Ice+1.0WLice (30 deg)	Yes	Y	1	1.2	2	1.2	3	1	6	0.87	7	0.5
28	1.2DL+1.2DLequip+1.0Ice+1.0WLice (60 deg)	Yes	Y	1	1.2	2	1.2	3	1	6	0.5	7	0.87
29	1.2DL+1.2DLequip+1.0Ice+1.0WLice (90 deg)	Yes	Y	1	1.2	2	1.2	3	1	7	1		
30	1.2DL+1.2DLequip+1.0Ice+1.0WLice (120 deg)	Yes	Y	1	1.2	2	1.2	3	1	6	-0.5	7	0.87
31	1.2DL+1.2DLequip+1.0Ice+1.0WLice (150 deg)	Yes	Y	1	1.2	2	1.2	3	1	6	-0.87	7	0.5
32	1.2DL+1.2DLequip+1.0Ice+1.0WLice (180 deg)	Yes	Y	1	1.2	2	1.2	3	1	6	-1		
33	1.2DL+1.2DLequip+1.0Ice+1.0WLice (210 deg)	Yes	Y	1	1.2	2	1.2	3	1	6	-0.87	7	-0.5
34	1.2DL+1.2DLequip+1.0Ice+1.0WLice (240 deg)	Yes	Y	1	1.2	2	1.2	3	1	6	-0.5	7	-0.87
35	1.2DL+1.2DLequip+1.0Ice+1.0WLice (270 deg)	Yes	Y	1	1.2	2	1.2	3	1	7	-1		
36	1.2DL+1.2DLequip+1.0Ice+1.0WLice (300 deg)	Yes	Y	1	1.2	2	1.2	3	1	6	0.5	7	-0.87
37	1.2DL+1.2DLequip+1.0Ice+1.0WLice (330 deg)	Yes	Y	1	1.2	2	1.2	3	1	6	0.87	7	-0.5
38	DL+DLequip		Y	1	1	2	1						
39	DL+DLequip+0.6WL (0 deg)		Y	1	1	2	1	4	0.6				
40	DL+DLequip+0.6WL (90 deg)		Y	1	1	2	1	5	0.6				
41	DL+DLequip+0.75(0.6WL (0 deg))		Y	1	1	2	1	4	0.45				
42	DL+DLequip+0.75(0.6WL (90 deg))		Y	1	1	2	1	5	0.45				
43	0.6DL+0.6DLequip+0.6WL (0 deg)		Y	1	0.6	2	0.6	4	0.6				
44	0.6DL+0.6DLequip+0.6WL (90 deg)		Y	1	0.6	2	0.6	5	0.6				
45	0.6DL+0.6DLequip		Y	1	0.6	2	0.6						
46	DL+DLequip+0.7Ice		Y	1	1	2	1	3	0.7				
47	DL+DLequip+0.7Ice+0.7WLice (0 deg)		Y	1	1	2	1	3	0.7	6	0.7		
48	DL+DLequip+0.7Ice+0.7WLice (90 deg)		Y	1	1	2	1	3	0.7	7	0.7		
49	0.6DL+0.6DLequip+0.7Ice+0.7WLice (0 deg)		Y	1	0.6	2	0.6	3	0.7	6	0.7		
50	0.6DL+0.6DLequip+0.7Ice+0.7WLice (90 deg)		Y	1	0.6	2	0.6	3	0.7	7	0.7		

**Envelope AISC 15TH (360-16): LRFD Member Steel Code Checks**

Member	Shape	Code	CheckLoc[in]	LC	Shear	CheckLoc[in]	Dir	LC	phi*Pnc [lb]	phi*Pnt [lb]	phi*Mn y-y [k-ft]	phi*Mn z-z [k-ft]	Cb	Eqn
1	P1	PIPE 2.0	0.155	30.812	8	0.04	78.625	2	3087.226	32130	1.872	1.872	1.477	H1-1b
2	M2	PL6x0.25	0.353	4.988	2	0.143	4.988	y 11	43701.996	48600	0.253	5.512	1.003	H1-1b
3	M3	PL6x0.25	0.344	4.988	8	0.158	4.988	y 11	43701.996	48600	0.253	5.515	1.003	H1-1b
4	P2	PIPE 2.0	0.155	30.812	8	0.023	31.875	3	3087.226	32130	1.872	1.872	1.477	H1-1b
5	M5	PL6x0.25	0.337	4.988	8	0.159	4.988	y 11	43701.996	48600	0.253	5.502	1.001	H1-1b



Company : Herzog Engineering, LLC.  
 Designer : JJC  
 Job Number : 211426  
 Model Name : MIN Killebrew - Z Sector

9/17/2021  
 12:09:11 PM  
 Checked By : \_\_\_\_\_

**Envelope AISC 15TH (360-16): LRFD Member Steel Code Checks (Continued)**

Member	Shape	Code	Check	Loc[in]	LC	Shear	Check	Loc[in]	Dir	LC	phi*Pnc [lb]	phi*Pnt [lb]	phi*Mn y-y [k-ft]	phi*Mn z-z [k-ft]	Cb	Eqn
6	M6	PL6x0.25	0.347	4.988	2	0.142	4.988	y	5	43701.996	48600	0.253	5.501	1.001	H1-1b	
7	P3 & 5	PIPE 2.0	0.08	79.688	37	0.025	78.625		9	3087.226	32130	1.872	1.872	2.317	H1-1b*	
8	M8	PL6x0.25	0.289	0	8	0.072	4.988	y	11	43701.996	48600	0.253	5.504	1.001	H1-1b	
9	M9	PL6x0.25	0.259	0	2	0.074	4.988	y	5	43701.996	48600	0.253	5.5	1.001	H1-1b	
10	P4	PIPE 2.0	0.182	30.812	8	0.038	78.625		2	3087.226	32130	1.872	1.872	1.459	H1-1b	
11	M11	PL6x0.25	0.397	4.988	8	0.16	4.988	y	11	43701.996	48600	0.253	5.521	1.004	H1-1b	
12	M12	PL6x0.25	0.405	4.988	2	0.145	4.988	y	11	43701.996	48600	0.253	5.519	1.004	H1-1b	
13	M20	W4X13	0.39	27	13	0.115	54	y	8	106559.674	124092	7.884	16.956	1.379	H1-1b	
14	M21	W4X13	0.509	27	8	0.152	54	y	8	106559.674	124092	7.884	16.956	1.35	H1-1b	
15	M22	W4X13	0.501	27	8	0.149	54	y	8	106559.674	124092	7.884	16.956	1.341	H1-1b	
16	M23	W4X13	0.381	27	3	0.111	54	y	8	106559.674	124092	7.884	16.956	1.376	H1-1b	
17	M24	W4X13	0.733	0	8	0.136	66.604	y	15	81013.858	124092	7.884	16.956	2.178	H1-1b	
18	M25	W4X13	0.932	0	8	0.109	49.229	y	2	81013.858	124092	7.884	16.956	2.327	H1-1b	
19	M26	W4X13	0.938	0	8	0.115	49.229	y	8	81013.858	124092	7.884	16.956	2.377	H1-1b	
20	M27	W4X13	0.714	0	8	0.138	66.604	y	25	81013.858	124092	7.884	16.956	2.175	H1-1b	
21	M43	PIPE 2.0	0.317	9.25	5	0.072	9.25		5	5865.504	32130	1.872	1.872	1.66	H1-1b	
22	M44	PL3/8x9	0.045	6	34	0.816	6	y	5	102127.891	109350	0.854	20.503	1.996	H1-1b	
23	M45	PL3/8x9	0.043	6	29	0.911	6	y	5	102127.891	109350	0.854	20.503	2.254	H1-1b	
24	M46	PL3/8x9	0.045	6	28	0.908	6	y	5	102127.891	109350	0.854	20.503	1.919	H1-1b	